



PTC FUNCTION for Delta C2000 and CP2000

CONTENTS:

1	GENERAL	2
1.1	PTC for motor temperature protection.....	2
1.2	Standards.....	2
1.3	Motor layout.....	2
1.4	PTC characteristic.....	2
1.4.1	Definitions.....	3
1.4.2	PTC curve.....	3
1.4.3	PTC switching level.....	3
1.4.4	PTC input.....	3
2	C2000/CP2000 PARAMETERS AND WIRING	4
2.1	PTC wiring and connection.....	4
2.1.1	Recommendations and limitations.....	4
2.2	Parameters for PTC-function: Pr06.29 ~ Pr06.30 and Pr03-00, Pr03-15.....	4
3	DIMENSIONING	5
3.1	Connection diagram.....	5
3.2	General formula.....	5
3.3	Dimensioning R_1	5
3.3.1	Conditions for R_1	5
3.3.2	R_1 value.....	6
3.3.3	Conditions for PTC Level.....	6
3.3.4	PTC Level Pr06-30.....	7
3.4	Reset.....	7
3.5	Summary.....	7
3.5.1	Circuit & wiring.....	7
3.5.2	Parameter settings.....	8
4	CLIXON	9
4.1.1	Wiring for and connection of clixon.....	9
4.1.2	Parameter settings.....	9

1 GENERAL

1.1 PTC for motor temperature protection

To protect motors from overheating, PTCs (also called thermistors) are incorporated in the motor windings. At the pre-defined temperature the PTC's resistance suddenly increases. This can be measured. Especially when motors are used for long periods of time at low speeds, the cooling could be insufficient. In that case the motor can be equipped with optional PTCs (ask the motor manufacturer).

1.2 Standards

PTCs for motor protection are manufactured acc. to the standards DIN44081 (for single PTCs) and DIN44082 (for 3 PTCs in series).

1.3 Motor layout

A typical layout of the PTCs in a motor is as follows, whereby the 3 PTCs are connected in series. (In case of 6 PTCs in series, each winding incorporates 2 PTCs in series.)

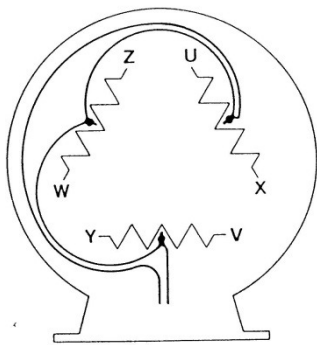

1.4 PTC characteristic

The characteristics of 1, 3 or 6 PTCs is shown below.

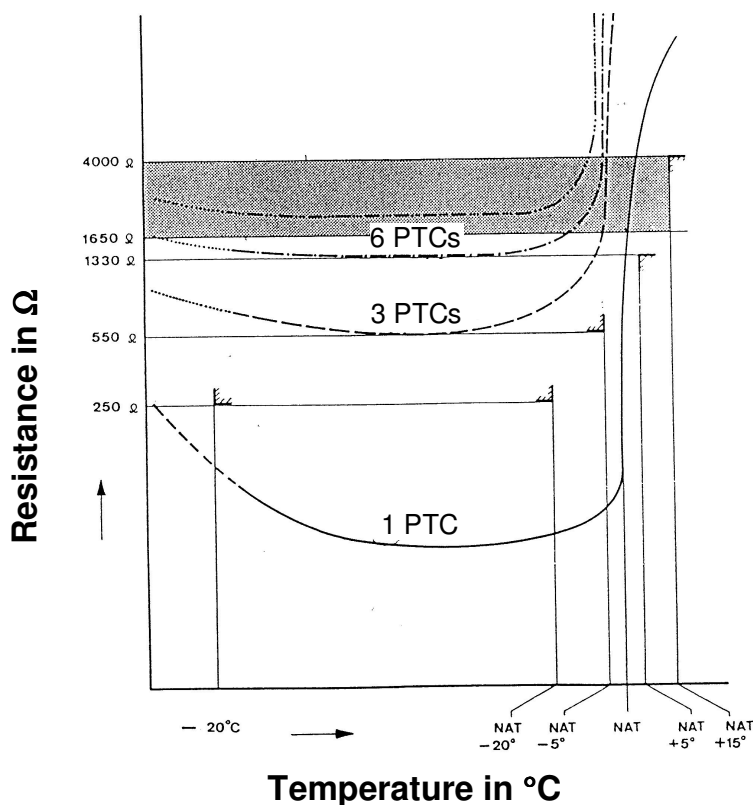

1.4.1 Definitions

NAT Normal Excitation Temperature (German abbreviation)

PTCs are manufactured to switch at a certain temperature, called "NAT".

1.4.2 PTC curve

The PTC curve for a single PTC is defined as follows:

Temperature range	Resistance	Measuring voltage
-20°C to NAT-20°C	$\leq 250\Omega$	2.5V
NAT-5°C	$\leq 550\Omega$	2.5V
NAT+5°C	$\geq 1330\Omega$	2.5V
NAT+15°C	$\geq 4000\Omega$	7.5V

1.4.3 PTC switching level

1 PTC switches between [NAT+5°C] and [NAT+15°C]

3 PTCs in series switch between [NAT-5°C] and [NAT+5°C]

6 PTCs in series switch between [NAT-20°C] and [NAT]

As a user of AC Motor Drives, you don't have to worry about the value of NAT, this has been taken care of by the motor manufacturer. The standardisation of PTCs ensures they switch at pre-defined resistance levels.

1.4.4 PTC input

A PTC-input should have the following functionality:

$R_{PTC} < 1650\Omega$: may not switch
 $1650\Omega < R_{PTC} < 4000\Omega$: switch
 $R_{PTC} > 4000\Omega$: must have switched

2 C2000/CP2000 PARAMETERS AND WIRING

Via a number of parameters the VFD-C and VFD-CP offer full flexibility to set the Motor PTC Overheat Protection Level and the action when the protection level is reached.

Refer to the VFD-C and VFD-CP User Manuals for an extensive description of the parameters.

2.1 PTC wiring and connection

The PTC is connected to the AVI input as follows.

Note: When used for PTC, the AVI input cannot be used for frequency command.

Note: For AUI and ACI, both in 0-10V, the procedure is the same.

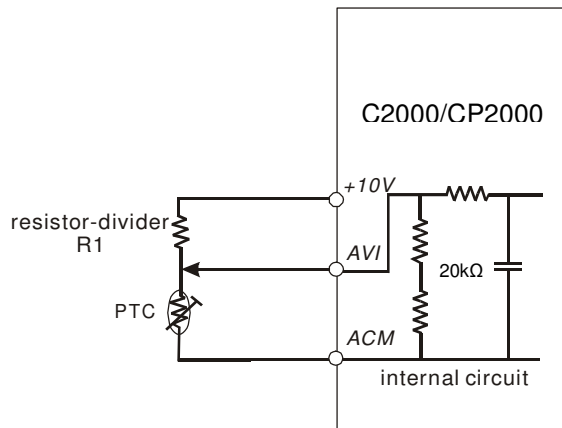

2.1.1 Recommendations and limitations

R1	1~20kΩ
U _{+10V}	10.4~11.2V
AVI impedance	20kΩ

2.2 Parameters for PTC-function: Pr06.29 ~ Pr06.30 and Pr03-00, Pr03-15

For extensive description of the parameters, please refer to the User Manual, Chapter 12.

Parameter	Description	Range/Setting	Unit	Default
06-29	PTC Overheat treatment Sets the action when the PTC Overheat Warning Level (P06.30) is reached.	0=Warn and keep running 1=Warn and ramp to stop 2=Warn and coast to stop 3=No warning		0
06-30	PTC Level Sets the Alarm Level. The VFD-C displays blinking [PtC2]. Action acc. to P06.30.	0.0~100.0%	0.1%	50.0%
03-00	AVI function Selects the AVI function. Set 6 to select PTC input.	0~17	n.a	1
03-15	AVI Filter Time Selects the AVI filter time (in noisy environment).	0.00~20.00	0.01s	0.01

3 DIMENSIONING

The following info can help you dimensioning the circuit and setting the parameters for PTCs acc. to DIN44081/44082.

3.1 Connection diagram

Connect the PTC as follows:

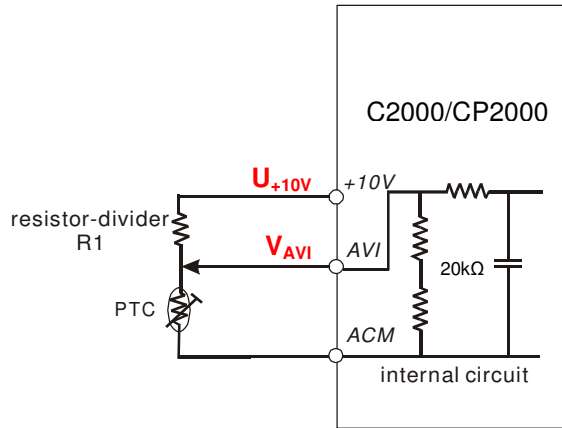

3.2 General formula

The general formula for calculating the voltage V_{AVI} on AVI is (depending on R_1 , U_{+10V} and R_{PTC}):

$$V_{AVI} = U_{+10V} \frac{R_{PTC} \cdot 20k}{R_{PTC} \cdot (20k + R_1) + 20k \cdot R_1} \quad [1]$$

The general formula for calculating R_1 (depending on V_{AVI} , U_{+10V} and R_{PTC}):

$$R_1 = \left(\frac{U_{+10V}}{V_{AVI}} - 1 \right) \cdot \frac{R_{PTC} \cdot 20k}{R_{PTC} + 20k} \quad [2]$$

3.3 Dimensioning R_1

Refer to 1.4.2 and 1.4.4.

3.3.1 Conditions for R_1

At $R_{PTC} \leq 1650\Omega$ the input AVI may not have switched and the voltage must be ca. 2.5V. The worst-case condition is $U_{+10V} = 11.2V$.

From [2] follows $R_1 = \left(\frac{11.2}{2.5} - 1 \right) \cdot \frac{1650 \cdot 20k}{1650 + 20k} = 5304\Omega$

You can also refer to the following graph:

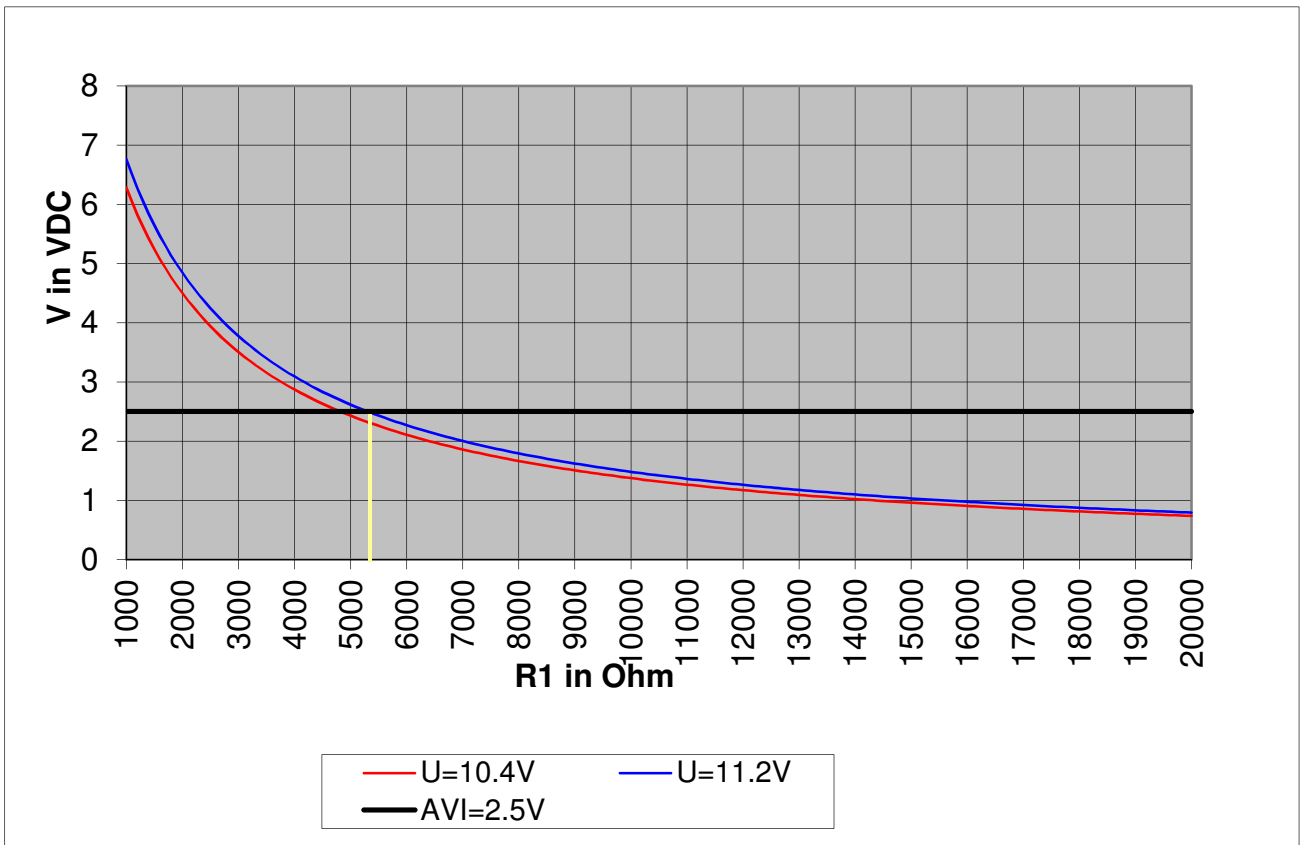

3.3.2 R₁ value

Select R₁=5600Ω ±10%. This is the nearest E12 value.

3.3.3 Conditions for PTC Level

At R_{PTC} ≥ 4000Ω the input AVI must have switched and the voltage must preferably be ca. 7.5V but this is neither mandatory nor critical. The display will show OH3.

The worst-case condition is U_{+10V} = 10.4V and R₁=5600Ω +10% (=6160Ω).

$$\text{From [2] follows } V_{AVI} = 10.4 \frac{4000 \cdot 20k}{4000 \cdot (20k + 6160) + 20k \cdot 6160} = 3.652V$$

This can also be read from the following graph:

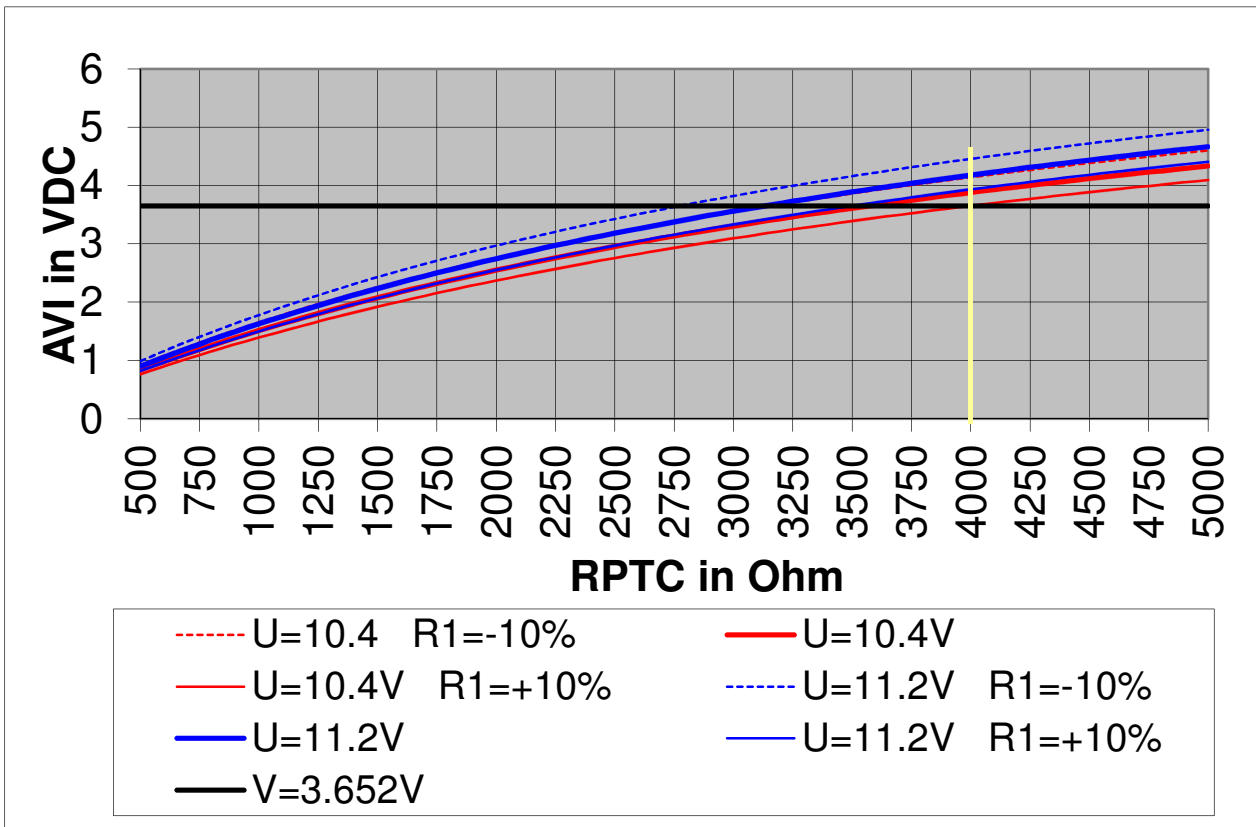

3.3.4 PTC Level Pr06-30

The Overheat Alarm level now can be set to 3.652V by setting Pr06-30=36.5%.

Note: When the PTC Level is reached, the drive will react acc. to Pr06-29 setting and display OH3.

3.4 Reset

When the motor temperature has decreased and the voltage level on AVI is lower than Pr06-30, the drive can be reset.

Because there is no hysteresis, it is recommended to set a delay of 5-10s for the used analogue input (Pr03-15~Pr03-17).

3.5 Summary

3.5.1 Circuit & wiring

Please use shielded cable for connecting the PTC.

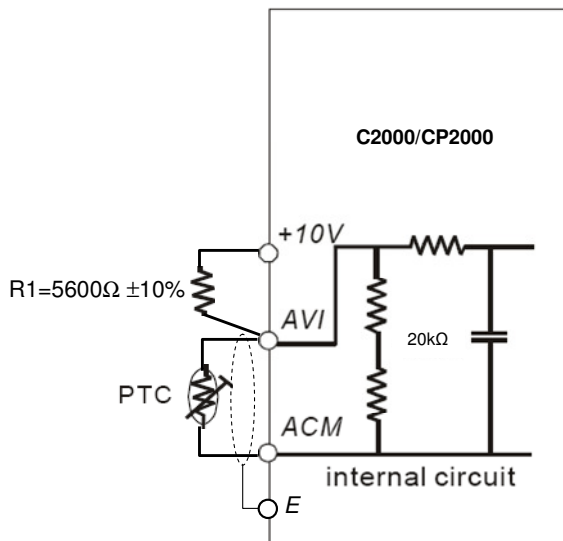

3.5.2 Parameter settings

Parameter	Description	Range/Setting	Unit	Setting
03-00~ 03-02	AVI, ACI, AUI function	0~17		6 *
03-15~ 03-17	AVI Filter Time Selects the AVI filter time (in noisy environment).	0.00~20.00	0.01s	5.00~10.00s
06-30	PTC Level	0.0~100.0%	0.1%	50.0%
06-29	PTC Detection Selection	0=Warn and keep running 1=Warn and ramp to stop 2=Warn and coast to stop 3=No warning		User selection

* Set one analogue input for PTC. ACI and AUI need to be set to 0-10V operation. Refer to the user manual.

4 CLIXON

A clixon is a contact that opens at the specified temperature. They are sometimes used for motor protection.

4.1.1 Wiring for and connection of clixon

Use shielded cable to connect the clixon.

R1 can also be 5k6 but this value is not critical.

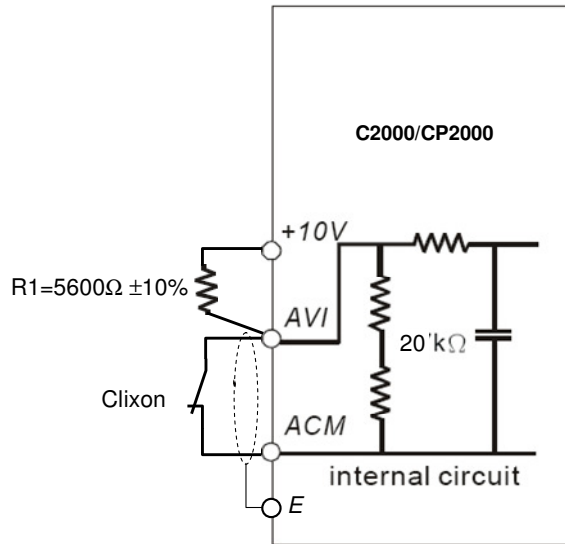

4.1.2 Parameter settings

Parameter	Description	Range/Setting	Unit	Setting
03-00~ 03-02	AVI, ACI, AUI function	0~17		6 *
03-15~ 03-17	AVI Filter Time Selects the AVI filter time (in noisy environment).	0.00~20.00	0.01s	5.00~10.00s
06-30	PTC Level	0.0~100.0%	0.1%	50.0%
06-29	PTC Detection Selection	0=Warn and keep running 1=Warn and ramp to stop 2=Warn and coast to stop 3=No warning		User selection

* Set one analogue input for PTC. ACI and AUI need to be set to 0-10V operation. Refer to the user manual.