



# Application Manual for C2000, CP2000, CH2000 Series Delta AC Motor Drive



109456, Москва, 1-й Вешняковский пр-д, д.2  
Тел.: +7 (495) 799-82-00, +7 (800) 600-49-09

отдел продаж: [sales@owenkomplekt.ru](mailto:sales@owenkomplekt.ru)

тех. поддержка: [consultant@owenkomplekt.ru](mailto:consultant@owenkomplekt.ru)

[www.owenkomplekt.ru](http://www.owenkomplekt.ru)



# Table of Contents

<b>1. EMC</b> .....	<b>1</b>
<b>1.1 Troubleshooting</b> .....	<b>1</b>
<b>1.2 EMI Input Filter</b> .....	<b>3</b>
1.2.1 Installation of EMI Input Filter.....	3
1.2.2 Installation.....	3
1.2.3 Installation Notices.....	4
1.2.4 The DELTA C2000 Series with Filters.....	5
1.2.5 Capacitive Noise Filter.....	7
<b>1.3 Shielding Wire</b> .....	<b>7</b>
1.3.1 Connection of Shielded Cables.....	7
<b>1.4 Zero-phase Reactor</b> .....	<b>8</b>
1.4.1 Installation.....	9
1.4.2 Installation Notices.....	9
1.4.3 Dimensions of DELTA Zero-phase Reactor.....	10
<b>1.5 Leakage Current</b> .....	<b>18</b>
1.5.1 Precautions for Leakage Current.....	18
1.5.2 Installation Recommendations for the Leakage Circuit Breaker.....	18
<b>1.6 Wiring Precautions</b> .....	<b>19</b>
<b>1.7 Proper Arrangements for Housing and Internal Components</b> .....	<b>22</b>
<b>2. Harmonic</b> .....	<b>23</b>
<b>2.1 Installation of AC\DC Reactor</b> .....	<b>23</b>
2.1.1 Installation.....	23
2.1.2 DELTA C/CP/CH Series AC Reactor Specifications.....	25
2.1.3 Specifications of THDi after an AC/DC Reactor Is Combined with DELTA Frequency Converter.....	33
<b>3. Output Reactor</b> .....	<b>34</b>
<b>3.1 Installation of Output Reactor</b> .....	<b>34</b>

3.2	Specification of Size.....	35
3.3	Output Reactor and the Length of Output Wire.....	39
4.	Single Phase Application.....	46
4.1	Introduction to the Application of Frequency Reactor and Single-phase Power System.....	46
4.2	Key Items to Consider When Using the Three-phase Frequency Converter for Single-phase Power Input.....	48
4.3	Input Frequency and Voltage Permissible Values.....	49
5.	Precautions for Heat Dissipation and Environment Conditions.....	55
5.1	Troubleshooting.....	55
5.2	Examples of Frequency Converters Affected by The Installation Environment.....	56
5.3	Cabinet Cooling Design.....	61
5.3.1	Installing the Drive In a Cabinet with Basic Protection.....	61
5.3.1.1	Ventilation Requirements and the Area of the Vent Opening.....	61
5.3.1.2	Clearance Required by a Drive.....	64
5.3.1.3	Separator Requirements.....	67
5.3.1.4	Design of Multiple Drives in the Cabinet.....	68
5.3.2	Designing the Drive In a Dust-proof Cabinet.....	70
5.3.2.1	Recommendations for a Protective Filter Mesh.....	70
5.3.2.2	Booster Fans Recommendation.....	70
5.3.3	How to Easily Clean the Dust off the Radiator.....	73
5.4	Installation Notices and Important Items.....	74
5.4.1	Cabinet Dimensions and Necessary Protective Measures.....	74
5.4.2	Selecting the Frequency Converter.....	76
5.4.2.1	Weight.....	76
5.4.2.2	The Size of the Frequency Converter's Mounting Holes, Recommended Screws and Tightness; for Drilling on the Cabinet...76	76
5.4.2.3	Locations of Air Inlet and Outlet on the Frequency Converter.....	76

5.4.2.4	The Required air Flow and Size of the Vent Opening in the Cabinet..	76
5.4.3	Cabinet Design.....	76
5.4.4	Installation and Construction of the Cabinet.....	79
<b>6.</b>	<b>Load Reduction and Overload Curves.....</b>	<b>86</b>
<b>6.1</b>	<b>The Load Reduction Curve of the Ambient Temperature.....</b>	<b>86</b>
6.1.1	Environmental Load Reduction Curve During General Use.....	86
6.1.2	Environmental Load Reduction Curve During Advanced Application.....	87
<b>6.2</b>	<b>Load Reduction Curve of Altitude.....</b>	<b>88</b>
<b>6.3</b>	<b>The Load Reduction Curve of Carrier Wave.....</b>	<b>89</b>
6.3.1	Load Reduction Curve of C2000.....	89
6.3.2	Load Reduction Curve of CH2000.....	93
6.3.3	Load Reduction Curve of CP2000.....	94
<b>6.4</b>	<b>Overload Curves.....</b>	<b>95</b>
6.4.1	Overload Curves.....	95
6.4.2	The Recovery Time from an Overload.....	100
<b>7.</b>	<b>Brake Module and Brake Resistor.....</b>	<b>103</b>
<b>7.1</b>	<b>Selection Flow.....</b>	<b>104</b>
<b>7.2</b>	<b>Data Calculation.....</b>	<b>106</b>
<b>7.3</b>	<b>Select Brake Resistor.....</b>	<b>109</b>
<b>7.4</b>	<b>Select Brake Module.....</b>	<b>111</b>
7.4.1	Built-in Brake Module.....	111
7.4.2	External Brake Module Drive.....	112
<b>7.5</b>	<b>Example Calculation.....</b>	<b>113</b>
<b>7.6</b>	<b>Braking Capability.....</b>	<b>116</b>
7.6.1	Braking Capability of C2000.....	116
7.6.2	Braking Capability of CH2000.....	120
7.6.3	Braking Capability of CP2000.....	124
7.6.4	Brake Unit.....	128
<b>8.</b>	<b>Estimation of Reliability and Key Component Life.....</b>	<b>132</b>

<b>8.1 Reliability Prediction and Key Component Life of C2000.....</b>	<b>133</b>
8.1.1 Reliability Prediction Report (by FIDES guide).....	133
8.1.2 Key Component Life Report.....	135
8.1.3 MTBF Prediction Report (based on Field Data).....	136
<b>8.2 Reliability Prediction and Key Component Life of CH2000.....</b>	<b>138</b>
8.2.1 Reliability Prediction Report (by FIDES guide).....	138
8.2.2 Key Component Life Report.....	140
<b>8.3 Reliability Prediction and Key Component Life of CP2000.....</b>	<b>141</b>
8.3.1 Reliability Prediction Report (by FIDES guide).....	141
8.3.2 Key Component Life Report.....	143
<b>Appendix A.....</b>	<b>144</b>
<b>A.1 EMC Filter Size.....</b>	<b>144</b>
<b>A.2 Size of the Zero-phase Reactor.....</b>	<b>150</b>
<b>A.3 Specifications of Recommended Sunon AC Fan.....</b>	<b>151</b>

# 1. EMC

## 1.1 Troubleshooting

There are power switching components in frequency converters; therefore if the frequency converters are not properly installed or grounded, they might cause interference or interruptions to other equipment as well as the frequency converters. If you have followed DELTA's recommended installation configurations but are still encountering problems, please refer to the following steps.

Item	Problem	Solution	Reference page
1.1	The power source of the panel is receiving interference from the frequency converter, causing malfunction of other equipment.	1.1.1 Check if the wiring is in line with the wiring precautions" section to prevent noise coupling.	<a href="#">P.24</a>
		1.1.2 It is recommended to use shielded wires for connecting the frequency converter and the motor to prevent the coupling effect of the motor wire and other equipment.	<a href="#">P.07</a>
		1.1.3 It is recommended to use a zero-phase reactor which can effectively up press the noise from the motor wire.	<a href="#">P.08</a>
1.2	Sporadic OC and OL during machine operation or acceleration.	1.2.1 Check the grounding wire as well as the items in "wiring precautions".	<a href="#">P.24</a>
		1.2.2 Recommend installing a zero-phase reactor.	<a href="#">P.08</a>
		1.2.3 Check if the length of the motor wire is too long. If so, it is recommend to use an output reactor to reduce the long-wire effect.	<a href="#">P.46</a>
1.3	Interfering with the host computer	1.3.1 Check if the wiring is in line with the wiring precautions to prevent noise coupling.	<a href="#">P.24</a>
		1.3.2 Using shielded wire is recommended.	<a href="#">P.07</a>
		1.3.3 A zero-phase reactor is recommended for using with the output wire.	<a href="#">P.08</a>
		1.3.4 A capacitive noise filter or EMI filter is recommended. If it has already been used, please check the installation notices.	<a href="#">P.03</a>
		1.3.5 Attach a core to the communication cable to suppress noise.	
1.4	Interference from external terminal	1.4.1 A zero-phase reactor is recommended for using with the output wire.	<a href="#">P.08</a>
		1.4.2 A capacitive noise filter or EMI filter is recommended. If it has already been used, please check the installation notice.	<a href="#">P.03</a>
		1.4.3 Attach a core to the external terminal cable to suppress noise.	

<b>Item</b>	<b>Problem</b>	<b>Solution</b>	<b>Reference page</b>
<b>1.5</b>	Interference of PG card	1.5.1 It is recommended to use shielding wires for the connection between the frequency converter and motor to prevent the coupling effect between motor wire and other equipment.	<u>P.08</u>
<b>1.6</b>	Proximity switch interference	1.6.1 A capacitive noise filter or EMI filter is recommended. If it has already been used, please check the installation notice.	<u>P.03</u>
		1.6.2 A zero-phase reactor is recommended for the output wire.	<u>P.08</u>
<b>1.7</b>	A leakage circuit breaker trips due to excessive amounts of leakage current.	1.7.1 Check if the grounding is connected properly.	<u>P.23</u>
		1.7.2 It is recommended to install a leakage circuit breaker by each frequency converter.	

Please contact DELTA directly if the procedures above fail to solve the problem.

## 1.2 EMI input filter

### 1.2.1 Installation of EMI input filter

When the electrical current is passing through, the EMI filter can effectively solve the noise problem of the frequency converter and the interference of electromagnetic wave, thus reducing interference and enabling the equipment to operate accurately while and being protected. Within the noise interference, the 150K to 300MHz bands are called high frequency and 120Hz to 3000Hz bands are called low frequency. High frequency noise current has smaller amplitude but higher frequency, while low frequency noise current has larger amplitude but lower frequency. Both are conducted to the power supply system via a power cord. The high frequency interference can only be effectively eliminated and suppressed with filters which generally consist of inductors and capacitors. Not all frequency converters have internal filters. In this case, an external filter is necessary.

### 1.2.2 Installation

Connect the power source to the filter in accordance with the instructions on the EMI input filter. Connect the wires between the filter and frequency converter. The EMI filter should be well grounded as shown in Figure 1.2.2-1.

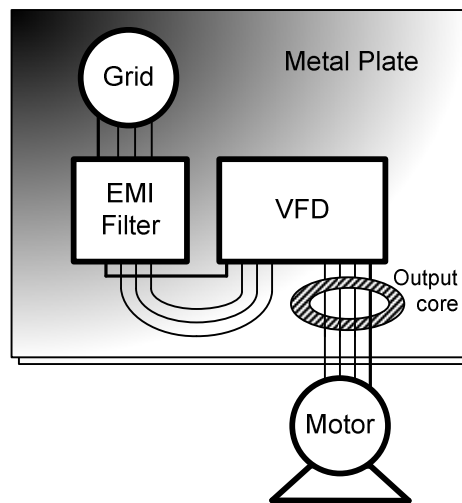

Figure 1.2.2-1 Diagram of EMI filter grounding



### 1.2.3 Installation notices

- 1.2.3.1 The current of the filter should be selected in accordance with the recommendations in the frequency converter manual. Proper grounding is very helpful in the reduction of radiation and conduction interference.
- 1.2.3.2 The shorter the wiring between the filter and the frequency converter, the better it is. Always try to use stranded wires or shielding wires to avoid signal interference of radiated noise.
- 1.2.3.3 If the output motor wire is too long, please install an output reactor.
- 1.2.3.4 Since most filters have metal casings, please follow all safety precautions. If touching the device is unavoidable, please turn off the power source or take appropriate protective measures to avoid the risk of electric shock.
- 1.2.3.5 Figure 5.1.3-1 illustrates the separation of output and input wires of the filter to avoid further noise of the input wires being coupled with the output wires.

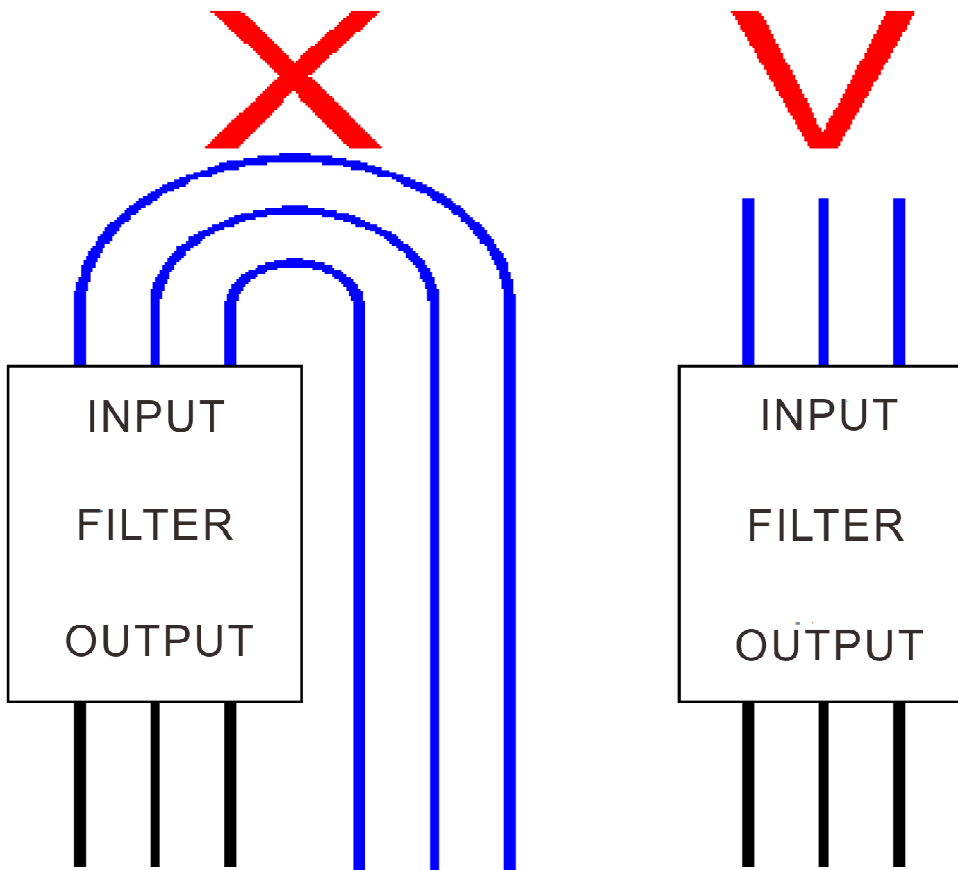

Figure 1.2.3-1: Wiring diagram of EMI filter

## 1.2.4 The DELTA C2000 series with filters

The specifications of DELTA C2000 with filter are shown in table 1.2.4-1 and 1.2.4-2. Please refer to Appendix A1 for the dimensions.

VFD	EMI Filter	VFD	EMI filter	VFD	EMI filter
C2000		CH2000		CP2000	
VFD007C23A(A)	EMF021A23A	VFD007CH23A(A)	EMF021A23A	VFD007CP23A(A)	EMF021A23A
VFD015C23A(A)		VFD015CH23A(A)		VFD015CP23A(A)	
VFD022C23A(A)		VFD022CH23A(A)		VFD022CP23A(A)	
VFD037C23A(A)		VFD037CH23A(A)		VFD037CP23A(A)	
VFD055C23A(B)	EMF056A23A	VFD055CH23A(B)	EMF056A23A	VFD055CP23A(A)	EMF056A23A
VFD075C23A(B)		VFD075CH23A(B)		VFD075CP23A(B)	
VFD110C23A(B)		VFD110CH23A(B)		VFD110CP23A(B)	
VFD150C23A(C)	KMF3100A	VFD150CH23A(C)	KMF3100A	VFD150CP23A(B)	KMF3100A
VFD185C23A(C)		VFD185CH23A(C)		VFD185CP23A(C)	
VFD220C23A(C)		VFD220CH23A(D)		VFD220CP23A(C)	
VFD300C23A(D)	B84143D0150R127	VFD300CH23A(D)	B84143D0150R127	VFD300CP23A(C)	B84143D0150R127
VFD370C23A(D)		VFD370CH23A(D)		VFD370CP23A(D)	
VFD450C23A(E)	B84143B0250S020	VFD450CH23A(E)	B84143B0250S020	VFD450CP23A(D)	B84143B0250S020
VFD550C23A(E)		VFD550CH23A(E)		VFD550CP23A(E)	
VFD750C23A(E)		VFD750CH23A(F)		VFD750CP23A(E)	
VFD900C23A(F)	B84143B0400S020			VFD900CP23A(E)	B84143B0400S020

Table 1.2.4-1: Specifications of EMI filter for 220V models

VFD	EMI Filter	VFD	EMI Filter	VFD	EMI Filter
C2000		CH2000		CP2000	
VFD007C43A(A)	EMF014A43A	VFD007CH43A(A)	EMF014A43A	VFD007CP43A(A)	EMF014A43A
VFD015C43A(A)		VFD015CH43A(A)		VFD015CP43A(A)	
VFD022C43A(A)		VFD022CH43A(A)		VFD022CP43A(A)	
VFD037C43A(A)	EMF018A43A	VFD037CH43A(A)	EMF018A43A	VFD037CP43A(A)	EMF018A43A
VFD055C43A(A)		VFD055CH43A(A)		VFD055CP43A(A)	
VFD075C43A(B)	EMF039A43A	VFD075CH43A(B)	EMF039A43A	VFD075CP43A(A)	EMF039A43A
VFD110C43A(B)		VFD110HC43A(B)		VFD110CP43A(B)	
VFD150C43A(B)		VFD150CH43A(B)		VFD150CP43A(B)	
VFD185C43A(C)	KMF370A	VFD185CH43A(C)	KMF370A	VFD185CP43A(B)	KMF370A
VFD220C43A(C)		VFD220CH43A(C)		VFD220CP43A(C)	
VFD300C43A(C)		VFD300CH43A(C)		VFD300CP43A(C)	
VFD370C43A(D)	B84143D0150R127	VFD370CH43A(D)	B84143D0150R127	VFD370CP43A(C)	B84143D0150R127
VFD450C43A(D)		VFD450CH43A(D)		VFD450CP43A(D)	
VFD550C43A(D)		VFD550CH43A(D)		VFD550CP43A(D)	
VFD750C43A(D)		VFD750CH43A(D)		VFD750CP43A(D)	
VFD900C43A(E)	B84143D0200R127	VFD900CH43A(E)	B84143D0200R127	VFD900CP43A(D)	B84143D0200R127
VFD1100C43A(E)		VFD1100CH43A(E)		VFD1100CP43A(E)	
VFD1320C43A(E)	MIF3400B	VFD1320CH43A(F)	MIF3400B	VFD1320CP43A(E)	MIF3400B
VFD1600C43A(F)		VFD1600CH43A(G)		VFD1600CP43A(F)	
VFD1850C43A(G)	MIF3800	VFD1850CH43A(G)	MIF3800	VFD1850CP43A(F)	MIF3800
VFD2200C43A(G)		VFD2200CH43A(G)		VFD2200CP43A(G)	
VFD2800C43A(H)	MIF3800	VFD2800CH43A(H)	MIF3800	VFD2800CP43A(G)	MIF3800
VFD3150C43A(H)				VFD3150CP43A(H)	
VFD3550C43A(H)				VFD3550CP43A(H)	
VFD4500C43A(H)	B84143B1000S020			VFD4000CP43A(H)	B84143B1000S020

Table 1.2.4-2: Specifications of EMI filter for 440V models

## 1.2.5 Capacitive noise filter

The relevant information is expected to be available during the third quarter of 2015.

### 1.3 Shielding wire

It is recommended to use isolated motor wires, as well as the signal wires and data wires. The recommended specification of the shielding wire can be selected from the three types of shielding wire in Figure 1.3-1. The appropriate size of the power cord should be based on the rated current.

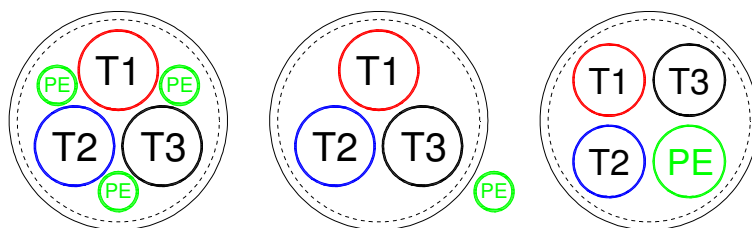

Figure 1.3-1

Recommended types of shielding wires. The left figure is a symmetric three-phase power cord with symmetric PE wires. The middle figure is a three-phased power cord with a separated PE wire. The right figure is the asymmetric three-phase power cord with a PE wire.

#### 1.3.1 Connection of shielded cables

- 1.3.1.1 Isolation is recommended for grounding at both ends. It is recommended to use a large contact area to ensure proper grounding. Be as close as possible to the juncture where cable is entering the cabinet.
- 1.3.1.2 The shorter the distance between the connection of the isolation layer of the shielded cable and the PE cable, the better it is. Through low inductance connection, impedance is reduced.
- 1.3.1.3 Use shielded cable connector to ensure the shielding effect, as shown in Figure 1.3.1-1.
- 1.3.1.4 If shielded cable and a zero-phase reactor are used, the pig tail of the shielded layer should not pass through the zero-phases reactor; and the shorter the distance of grounding is the better, as shown in Figure 1.3.1-2.

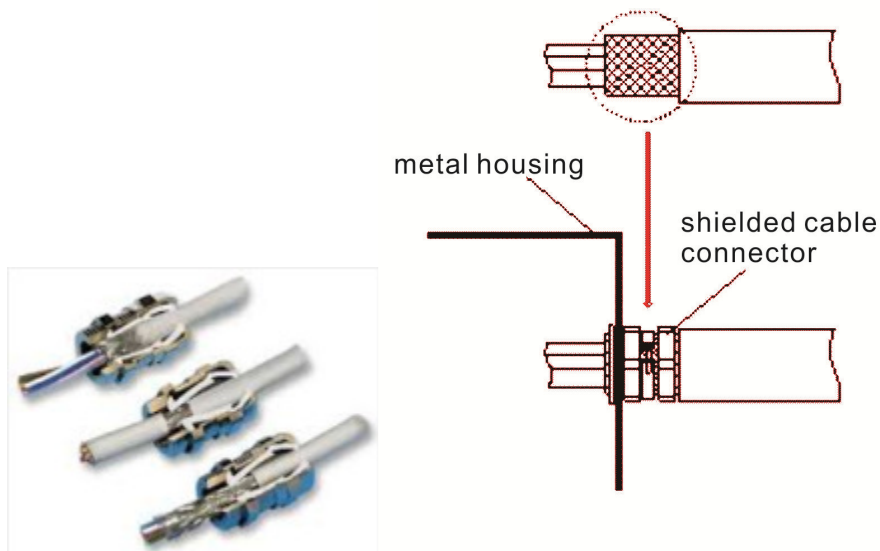

Figure 1.3.1-1 Shielded Cable Connector

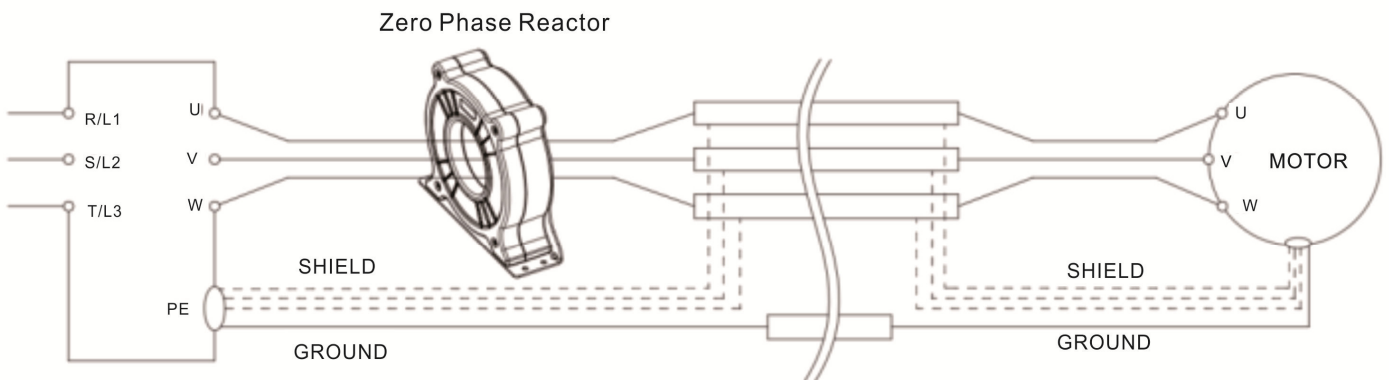

Figure 1.3.1-2: Single turn wiring diagram of a shielding wire with a zero-phase reactor

## 1.4 Zero-phase reactor

Installing a zero-phase reactor at the input or output side is another way to reduce interference. Because the current passing through the power input/output cord is high, attention should be paid to the saturation of the magnetic cord.

For the zero-phase power input/output cord, due to the heavy current load, the most ideal material is composite magnetic core which has strong anti-saturation and the resistivity is several times larger than pure magnetic metal, thus it can be used at higher frequencies, and high impedance can be achieved through the increase in the number of turns.

## 1.4.1 Installation

During installation, please pass the cable through at least one zero-phase reactor. Use an appropriate cable type for pressure resistance, flow resistance, insulation class and the diameter of the cord, i.e., the cable should pass through the zero-phase reactor appropriately. Please do not pass the cable through the grounding wire during wiring, only pass through the motor wire and power cord.

If a longer motor output wire is used, the zero-phase reactor can effectively reduce the interference at the output end. The installation of zero-phase reactor should be as close to the output of the frequency converter as possible. Figure 1.3.1-2 is the installation diagram of a single turn zero-phase reactor. If the diameter allows several turns, the installation of a multi-turn zero-phase reactor is as shown in Figure 1.4.1-1. The more turns, the better the noise suppression effect.

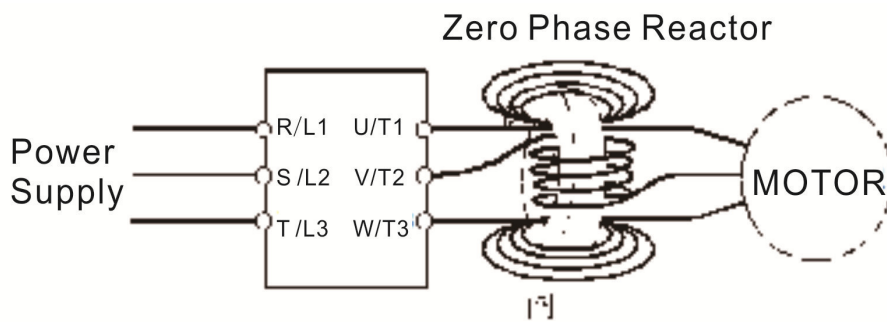

Figure 1.4.1-1 Multi-Turn Zero Phase Reactor

## 1.4.2 Installation notices

Install the zero-phase reactor at the output terminal of the frequency converter (U.V.W.). After the zero-phase converter is installed, it can reduce the electromagnetic radiation and load stress emitted by the wiring of the frequency converter. The number of zero-phase reactor required for a frequency converter depends on the length of wiring and the voltage of the frequency converter.

The normal operating temperature of the zero-phase reactor should be lower than 85°C (176°F). However, when the operation of the zero-phase reactor is saturated, its temperature may exceed 85°C (176°F). Please increase the number of zero-phase reactors to avoid saturation of the zero-phase reactor. The following are reasons that might cause saturation of the zero-phase reactors. For example: The wiring of the frequency converter is too long; the frequency converter drives several sets of load; the wiring is in parallel; the frequency converter uses high capacitance wiring. If the temperature of the zero-phase reactor exceeds 85°C (176°F) during the operation of the frequency converter, the number of the zero-phase reactor should be increased.

### 1.4.3 Dimensions of DELTA zero-phase reactor

The recommended specifications for the zero-phase reactor are shown in Table 1.4.3-1. Please refer to Appendix A.2 for dimensions. If the diameter of the wire exceeds the recommended value, please refer to the selection guide in Appendix A.2.

C2000 Series	Mini. Wire Gauge (Cross Sectional Area)	Max. Wire Gauge(Diameter)	Recommended Zero Phase Reactor
VFD007C23A	14AWG(2.1mm <sup>2</sup> )	8AWG(3.264mm)	RF008X00A
VFD015C23A	12AWG(3.3mm <sup>2</sup> )		
VFD022C23A	10AWG(5.3mm <sup>2</sup> )		
VFD037C23A	8AWG(8.4mm <sup>2</sup> )		
VFD007C43A	14AWG(2.1mm <sup>2</sup> )		
VFD007C43E	14AWG(2.1mm <sup>2</sup> )		
VFD015C43A	14AWG(2.1mm <sup>2</sup> )		
VFD015C43E	14AWG(2.1mm <sup>2</sup> )		
VFD022C43A	14AWG(2.1mm <sup>2</sup> )		
VFD022C43E	14AWG(2.1mm <sup>2</sup> )		
VFD037C43A	10AWG(5.3mm <sup>2</sup> )		
VFD037C43E	10AWG(5.3mm <sup>2</sup> )		
VFD040C43A	10AWG(5.3mm <sup>2</sup> )		
VFD040C43E	10AWG(5.3mm <sup>2</sup> )		
VFD055C43A	10AWG(5.3mm <sup>2</sup> )		
VFD055C43E	10AWG(5.3mm <sup>2</sup> )	RF008X00A	
VFD055C23A	8AWG(8.4mm <sup>2</sup> )		
VFD075C23A	6AWG(13.3mm <sup>2</sup> )		
VFD110C23A	4AWG(21.2mm <sup>2</sup> )	4AWG(5.189mm)	RF004X00A
VFD075C43A	8AWG(8.4mm <sup>2</sup> )		RF008X00A
VFD075C43E	8AWG(8.4mm <sup>2</sup> )		
VFD110C43A	8AWG(8.4mm <sup>2</sup> )		
VFD110C43E	8AWG(8.4mm <sup>2</sup> )		
VFD150C43A	6AWG(13.3mm <sup>2</sup> )	4AWG(5.189mm)	RF008X00A
VFD150C43E	6AWG(13.3mm <sup>2</sup> )		
VFD150C23A	1AWG(42.4mm <sup>2</sup> )	1/0AWG(8.252mm)	RF002X00A
VFD185C23A	1/0AWG(53.5mm <sup>2</sup> )		
VFD220C23A	1/0AWG(53.5mm <sup>2</sup> )		
VFD185C43A	4AWG(21.2mm <sup>2</sup> )		RF004X00A

C2000 Series	Mini. Wire Gauge (Cross Sectional Area)	Max. Wire Gauge(Diameter)	Recommended Zero Phase Reactor
VFD185C43E	4AWG(21.2mm <sup>2</sup> )		
VFD220C43A	4AWG(21.2mm <sup>2</sup> )		
VFD220C43E	4AWG(21.2mm <sup>2</sup> )		
VFD300C43A	2AWG(33.6mm <sup>2</sup> )		
VFD300C43E	2AWG(33.6mm <sup>2</sup> )		
			RF002X00A
DPD073T43S-00	1/0AWG(53.5mm <sup>2</sup> )	2/0AWG(9.226mm)	RF002X00A
DPD091T43S-00	2/0AWG(67.4mm <sup>2</sup> )		
DPD073T43S-21	1/0AWG(53.5mm <sup>2</sup> )		
DPD091T43S-21	1/0AWG(53.5mm <sup>2</sup> )		
VFD300C23A	4/0AWG(107mm <sup>2</sup> )	300MCM(13.91mm)	RF002X00A
VFD370C23A	250MCM(127mm <sup>2</sup> )		
VFD370C43A	1/0AWG(53.5mm <sup>2</sup> )		
VFD450C43A	2/0AWG(67.4mm <sup>2</sup> )		
VFD550C43A	3/0AWG(85mm <sup>2</sup> )		
VFD750C43A	300MCM(152mm <sup>2</sup> )		
VFD300C23E	3/0AWG(85mm <sup>2</sup> )	4/0AWG(11.68mm)	RF002X00A
VFD370C23E	4/0AWG(107mm <sup>2</sup> )		
VFD370C43E	1/0AWG(53.5mm <sup>2</sup> )	4/0AWG(11.68mm)	RF002X00A
VFD450C43E	1/0AWG(53.5mm <sup>2</sup> )		
VFD550C43E	2/0AWG(67.4mm <sup>2</sup> )		
VFD750C43E	4/0AWG(107mm <sup>2</sup> )		
VFD450C23A	1/0AWG(53.5mm <sup>2</sup> )*2		
VFD550C23A	3/0AWG(85mm <sup>2</sup> )*2		
VFD750C23A	4/0AWG(107mm <sup>2</sup> )*2		
VFD900C43A	1/0AWG(53.5mm <sup>2</sup> )*2		
VFD1100C43A	3/0AWG(85mm <sup>2</sup> )*2		
VFD450C23E	1/0AWG(53.5mm <sup>2</sup> )*2	4/0AWG(11.68mm)*2	RF300X00A
VFD550C23E	2/0AWG(67.4mm <sup>2</sup> )*2		
VFD750C23E	3/0AWG(85mm <sup>2</sup> )*2		
VFD900C43E	1/0AWG(53.5mm <sup>2</sup> )*2		
VFD1100C43E	2/0AWG(67.4mm <sup>2</sup> )*2		
VFD900C23A	300MCM(152mm <sup>2</sup> )*2	300MCM(13.91mm)*2	RF300X00A
VFD1300C43A	4/0AWG(107mm <sup>2</sup> )*2		
VFD1600C43A	300MCM(152mm <sup>2</sup> )*2		
VFD900C23E	4/0AWG(107mm <sup>2</sup> )*2	4/0AWG(11.68mm)*2	RF300X00A



C2000 Series	Mini. Wire Gauge (Cross Sectional Area)	Max. Wire Gauge(Diameter)	Recommended Zero Phase Reactor
VFD1320C43E	300MCM(152mm <sup>2</sup> )		
VFD1600C43E	4/0AWG(107mm <sup>2</sup> )*2		
VFD1850C43A	400MCM(203mm <sup>2</sup> )*2	500MCM(17.96mm)*2	RF300X00A
VFD2200C43A	500MCM(253mm <sup>2</sup> )*2		
VFD1850C43E	300MCM(152mm <sup>2</sup> )*2		
VFD2200C43E	400MCM(203mm <sup>2</sup> )*2	500MCM(17.96mm)*2	RF300X00A
VFD2800C43A	4/0AWG(107mm <sup>2</sup> )*4	300MCM(13.91mm)*4	RF300X00A
VFD3150C43A	300MCM(152mm <sup>2</sup> )*4		
VFD3550C43A	300MCM(152mm <sup>2</sup> )*4		
VFD2800C43E-1	300MCM(152mm <sup>2</sup> )*4		
VFD3150C43E-1	4/0AWG(107mm <sup>2</sup> )*4		
VFD3550C43E-1	300MCM(152mm <sup>2</sup> )*4		
VFD2800C4E	3/0AWG(85mm <sup>2</sup> )*4		
VFD3150C4E	4/0AWG(107mm <sup>2</sup> )*4		
VFD3550C4E	250MCM(127mm <sup>2</sup> )*4		
VFD4500C4E	300MCM(152mm <sup>2</sup> )*4		

Table 1.4.3-1 C2000 series: recommended specifications for the zero-phase reactor

CP2000 Series	Mini. Wire Gauge (Cross Sectional Area)	Max. Wire Gauge(Diameter)	Recommended Zero Phase Reactor
VFD007CP23A-21	14AWG(2.1mm <sup>2</sup> )	8AWG(3.264mm)	RF008X00A
VFD015CP23A-21	14AWG(2.1mm <sup>2</sup> )		RF008X00A
VFD022CP23A-21	14AWG(2.1mm <sup>2</sup> )		RF008X00A
VFD037CP23A-21	10AWG(5.3mm <sup>2</sup> )		RF008X00A
VFD055CP23A-21	10AWG(5.3mm <sup>2</sup> )		RF008X00A
VFD007CP43A-21	14AWG(2.1mm <sup>2</sup> )		RF008X00A
VFD015CP43B-21	14AWG(2.1mm <sup>2</sup> )	8AWG(3.264mm)	RF008X00A
VFD022CP43B-21	14AWG(2.1mm <sup>2</sup> )		RF008X00A
VFD037CP43B-21	14AWG(2.1mm <sup>2</sup> )		RF008X00A
VFD040CP43A-21	14AWG(2.1mm <sup>2</sup> )		RF008X00A
VFD055CP43B-21	12AWG(3.3mm <sup>2</sup> )		RF008X00A
VFD075CP43B-21	12AWG(3.3mm <sup>2</sup> )		RF008X00A
VFD007CP4EA-21	14AWG(2.1mm <sup>2</sup> )		RF008X00A
VFD015CP4EB-21	14AWG(2.1mm <sup>2</sup> )		RF008X00A
VFD022CP4EB-21	14AWG(2.1mm <sup>2</sup> )		RF008X00A
VFD037CP4EB-21	14AWG(2.1mm <sup>2</sup> )		RF008X00A

CP2000 Series	Mini. Wire Gauge (Cross Sectional Area)	Max. Wire Gauge(Diameter)	Recommended Zero Phase Reactor
VFD040CP4EA-21	12AWG(3.3mm <sup>2</sup> )		RF008X00A
VFD055CP4EB-21	10AWG(5.3mm <sup>2</sup> )		RF008X00A
VFD075CP4EB-21	10AWG(5.3mm <sup>2</sup> )		RF008X00A
VFD075CP23A-21	8AWG(8.4mm <sup>2</sup> )		RF008X00A
VFD110CP23A-21	6AWG(13.3mm <sup>2</sup> )		RF004X00A
VFD150CP23A-21	4AWG(21.2mm <sup>2</sup> )		RF004X00A
VFD110CP43B-21	8AWG(8.4mm <sup>2</sup> )	4AWG(5.189mm)	RF008X00A
VFD150CP43B-21	8AWG(8.4mm <sup>2</sup> )		RF008X00A
VFD185CP43B-21	6AWG(13.3mm <sup>2</sup> )		RF004X00A
VFD110CP4EB-21	8AWG(8.4mm <sup>2</sup> )		RF008X00A
VFD150CP4EB-21	8AWG(8.4mm <sup>2</sup> )	4AWG(5.189mm)	RF008X00A
VFD185CP4EB-21	6AWG(13.3mm <sup>2</sup> )		RF004X00A
VFD185CP23A -21	1AWG(42.4mm <sup>2</sup> )		RF002X00A
VFD220CP23A-21	1/0AWG(53.5mm <sup>2</sup> )		RF002X00A
VFD300CP23A-21	1/0AWG(53.5mm <sup>2</sup> )		RF002X00A
VFD220CP43A-21	4AWG(21.2mm <sup>2</sup> )		RF004X00A
VFD300CP43B-21	3AWG(26.7mm <sup>2</sup> )	1/0AWG(8.252mm)	RF002X00A
VFD370CP43B-21	2AWG(33.6mm <sup>2</sup> )		RF002X00A
VFD220CP4EB-21	4AWG(21.2mm <sup>2</sup> )		RF004X00A
VFD300CP4EB-21	3AWG(26.7mm <sup>2</sup> )		RF002X00A
VFD370CP4EB-21	2AWG(33.6mm <sup>2</sup> )		RF002X00A
VFD370CP23A-00	4/0AWG(107mm <sup>2</sup> )		RF002X00A
VFD450CP23A-00	300MCM(152mm <sup>2</sup> )		RF002X00A
VFD450CP43S-00	1/0AWG(53.5mm <sup>2</sup> )		RF002X00A
VFD450CP43A-00	1/0AWG(53.5mm <sup>2</sup> )	300MCM(13.91mm)	RF002X00A
VFD550CP43S-00	2/0AWG(67.4mm <sup>2</sup> )		RF002X00A
VFD550CP43A-00	2/0AWG(67.4mm <sup>2</sup> )		RF002X00A
VFD750CP43B-00	3/0AWG(85mm <sup>2</sup> )		RF002X00A
VFD900CP43A-00	300MCM(152mm <sup>2</sup> )		RF002X00A
VFD370CP23A-21	4/0AWG(107mm <sup>2</sup> )	4/0AWG(11.68mm)	RF002X00A
VFD450CP23A-21	4/0AWG(107mm <sup>2</sup> )		RF002X00A
VFD450CP43S-21	1/0AWG(53.5mm <sup>2</sup> )		RF002X00A
VFD450CP43A-21	1/0AWG(53.5mm <sup>2</sup> )	4/0AWG(11.68mm)	RF002X00A
VFD550CP43S-21	2/0AWG(67.4mm <sup>2</sup> )		RF002X00A
VFD550CP43A-21	2/0AWG(67.4mm <sup>2</sup> )		RF002X00A

CP2000 Series	Mini. Wire Gauge (Cross Sectional Area)	Max. Wire Gauge(Diameter)	Recommended Zero Phase Reactor	
VFD750CP43B-21	3/0AWG(85mm <sup>2</sup> )		RF002X00A	
VFD900CP43A-21	4/0AWG(107mm <sup>2</sup> )		RF002X00A	
VFD550CP23A-00	2/0AWG(67.4mm <sup>2</sup> )	300MCM(13.91mm)	RF300X00A	
VFD750CP23A-00	3/0AWG(85mm <sup>2</sup> )		RF300X00A	
VFD900CP23A-00	4/0AWG(107mm <sup>2</sup> )		RF300X00A	
VFD1100CP43A-00	2/0AWG(67.4mm <sup>2</sup> )		RF300X00A	
VFD1320CP43B-00	2/0AWG(67.4mm <sup>2</sup> )		RF300X00A	
VFD550CP23A-21	2/0AWG(67.4mm <sup>2</sup> )		RF300X00A	
VFD750CP23A-21	3/0AWG(85mm <sup>2</sup> )	4/0AWG(11.68mm)	RF300X00A	
VFD900CP23A-21	4/0AWG(107mm <sup>2</sup> )		RF300X00A	
VFD1100CP43A-21	2/0AWG(67.4mm <sup>2</sup> )		RF300X00A	
VFD1320CP43B-21	2/0AWG(67.4mm <sup>2</sup> )		RF300X00A	
VFD1600CP43A-00	4/0AWG(107mm <sup>2</sup> )*2		300MCM(13.91mm)	RF300X00A
VFD1850CP43B-00	300MCM(152mm <sup>2</sup> )*2		RF300X00A	
VFD1600CP43A-21	4/0AWG(107mm <sup>2</sup> )*2	4/0AWG(11.68mm)	RF300X00A	
VFD1850CP43B-21	4/0AWG(107mm <sup>2</sup> )*2	4/0AWG(11.68mm)	RF300X00A	
VFD2200CP43A-00	400MCM(203mm <sup>2</sup> )*2	500MCM(17.96mm)*2	RF300X00A	
VFD2800CP43A-00	500MCM(253mm <sup>2</sup> )*2		RF300X00A	
VFD2200CP43A-21	400MCM(203mm <sup>2</sup> )*2		RF300X00A	
VFD2800CP43A-21	500MCM(253mm <sup>2</sup> )*2		RF300X00A	
VFD3150CP43A-00	4/0AWG(107mm <sup>2</sup> )*4	300MCM(13.91mm)*4	RF300X00A	
VFD3550CP43A-00	250MCM(127mm <sup>2</sup> )*4		RF300X00A	
VFD4000CP43A-00	300MCM(152mm <sup>2</sup> )*4		RF300X00A	
VFD4000CP43C-00	300MCM(152mm <sup>2</sup> )*4		RF300X00A	
VFD3150CP43C-00	4/0AWG(107mm <sup>2</sup> )*4		RF300X00A	
VFD3550CP43C-00	250MCM(127mm <sup>2</sup> )*4		RF300X00A	
VFD3150CP43C-21	4/0AWG(107mm <sup>2</sup> )*4		RF300X00A	
VFD3550CP43C-21	250MCM(127mm <sup>2</sup> )*4		RF300X00A	
VFD4000CP43C-21	300MCM(152mm <sup>2</sup> )*4		RF300X00A	

Table 1.4.3-2 CP2000 series: recommended specifications for the zero-phase reactor

CH2000 Series	Mini. Wire Gauge (Cross Sectional Area)	Max. Wire Gauge(Diameter)	Recommended Zero Phase Reactor	
VFD007CH23A-21	14AWG(2.1mm <sup>2</sup> )	8AWG(3.264mm)	RF008X00A	
VFD015CH23A-21	12AWG(3.3mm <sup>2</sup> )		RF008X00A	
VFD022CH23A-21	10AWG(5.3mm <sup>2</sup> )		RF008X00A	
VFD037CH23A-21	8AWG(8.4mm <sup>2</sup> )	8AWG(3.264mm)	RF008X00A	
VFD007CH43A-21	14AWG(2.1mm <sup>2</sup> )		RF008X00A	
VFD007CH4EA-21	14AWG(2.1mm <sup>2</sup> )		RF008X00A	
VFD015CH43A-21	14AWG(2.1mm <sup>2</sup> )		RF008X00A	
VFD015CH4EA-21	14AWG(2.1mm <sup>2</sup> )		RF008X00A	
VFD022CH43A-21	14AWG(2.1mm <sup>2</sup> )		RF008X00A	
VFD022CH4EA-21	14AWG(2.1mm <sup>2</sup> )		RF008X00A	
VFD037CH43A-21	10AWG(5.3mm <sup>2</sup> )		RF008X00A	
VFD037CH4EA-21	10AWG(5.3mm <sup>2</sup> )		RF008X00A	
VFD055CH43A-21	10AWG(5.3mm <sup>2</sup> )		RF008X00A	
VFD055CH4EA-21	10AWG(5.3mm <sup>2</sup> )		RF008X00A	
VFD055CH23A-21	8AWG(8.4mm <sup>2</sup> )		4AWG(5.189mm)	RF008X00A
VFD075CH23A-21	6AWG(13.3mm <sup>2</sup> )			RF004X00A
VFD110CH23A-21	4AWG(21.2mm <sup>2</sup> )			RF004X00A
VFD075CH43A-21	8AWG(8.4mm <sup>2</sup> )	RF008X00A		
VFD075CH4EA-21	10AWG(5.3mm <sup>2</sup> )	RF008X00A		
VFD110CH43A-21	8AWG(8.4mm <sup>2</sup> )	RF008X00A		
VFD110CH4EA-21	8AWG(8.4mm <sup>2</sup> )	RF008X00A		
VFD150CH43A-21	6AWG(13.3mm <sup>2</sup> )	RF004X00A		
VFD150CH4EA-21	8AWG(8.4mm <sup>2</sup> )	RF008X00A		
VFD150CH23A	1AWG(42.4mm <sup>2</sup> )	1/0AWG(8.252mm)		RF002X00A
VFD185CH23A	1/0AWG(53.5mm <sup>2</sup> )		RF002X00A	
VFD185CH43A	4AWG(21.2mm <sup>2</sup> )		RF004X00A	
VFD185CH43E	6AWG(13.3mm <sup>2</sup> )		RF004X00A	
VFD220CH43A	4AWG(21.2mm <sup>2</sup> )		RF004X00A	
VFD220CH43E	4AWG(21.2mm <sup>2</sup> )		RF004X00A	
VFD300CH43A	2AWG(33.6mm <sup>2</sup> )		RF002X00A	
VFD300CH43E	3AWG(26.7mm <sup>2</sup> )		RF002X00A	
VFD370CH43S	2/0AWG(67.4mm <sup>2</sup> )	2/0AWG(9.226mm)	RF002X00A	
VFD220CH23A-00	1/0AWG(53.5mm <sup>2</sup> )	300MCM(13.91mm)	RF002X00A	
VFD300CH23A-00	4/0AWG(107mm <sup>2</sup> )		RF002X00A	

CH2000 Series	Mini. Wire Gauge (Cross Sectional Area)	Max. Wire Gauge(Diameter)	Recommended Zero Phase Reactor
VFD370CH23A-00	250MCM(127mm <sup>2</sup> )		RF002X00A
VFD370CH43A-00	1/0AWG(53.5mm <sup>2</sup> )		RF002X00A
VFD450CH43A-00	2/0AWG(67.4mm <sup>2</sup> )		RF002X00A
VFD550CH43A-00	3/0AWG(85mm <sup>2</sup> )		RF002X00A
VFD750CH43A-00	300MCM(152mm <sup>2</sup> )		RF002X00A
VFD220CH23A-21	1/0AWG(53.5mm <sup>2</sup> )	4/0AWG(11.68mm)	RF002X00A
VFD300CH23A-21	3/0AWG(85mm <sup>2</sup> )		RF002X00A
VFD370CH23A-21	4/0AWG(107mm <sup>2</sup> )		RF002X00A
VFD370CH43A-21	1/0AWG(53.5mm <sup>2</sup> )		RF002X00A
VFD450CH43A-21	1/0AWG(53.5mm <sup>2</sup> )	4/0AWG(11.68mm)	RF002X00A
VFD550CH43A-21	2/0AWG(67.4mm <sup>2</sup> )		RF002X00A
VFD750CH43A-21	4/0AWG(107mm <sup>2</sup> )		RF002X00A
VFD220CH23A-00	1/0AWG(53.5mm <sup>2</sup> )	300MCM(13.91mm)	RF300X00A
VFD300CH23A-00	4/0AWG(107mm <sup>2</sup> )		RF300X00A
VFD370CH23A-00	250MCM(127mm <sup>2</sup> )		RF300X00A
VFD370CH43A-00	1/0AWG(53.5mm <sup>2</sup> )		RF300X00A
VFD450CH43A-00	2/0AWG(67.4mm <sup>2</sup> )		RF300X00A
VFD550CH43A-00	3/0AWG(85mm <sup>2</sup> )		RF300X00A
VFD750CH43A-00	300MCM(152mm <sup>2</sup> )		RF300X00A
VFD220CH23A-21	1/0AWG(53.5mm <sup>2</sup> )		4/0AWG(11.68mm)
VFD300CH23A-21	3/0AWG(85mm <sup>2</sup> )	RF300X00A	
VFD370CH23A-21	4/0AWG(107mm <sup>2</sup> )	RF300X00A	
VFD370CH43A-21	1/0AWG(53.5mm <sup>2</sup> )	RF300X00A	
VFD450CH43A-21	1/0AWG(53.5mm <sup>2</sup> )	RF300X00A	
VFD550CH43A-21	2/0AWG(67.4mm <sup>2</sup> )	RF300X00A	
VFD750CH43A-21	4/0AWG(107mm <sup>2</sup> )	RF300X00A	
VFD750CH23A-00	3/0AWG(85mm <sup>2</sup> )*2	300MCM(13.91mm)	RF300X00A
VFD1320CH43A-00	4/0AWG(107mm <sup>2</sup> )*2		RF300X00A
VFD750CH23A-21	4/0AWG(107mm <sup>2</sup> )*2	4/0AWG(11.68mm)	RF300X00A
VFD1320CH43A-21	3/0AWG(85mm <sup>2</sup> )*2	4/0AWG(11.68mm)	RF300X00A
VFD1600CH43A-00	300MCM(152mm <sup>2</sup> )*2	500MCM(17.96mm)*2	RF300X00A
VFD1850CH43A-00	400MCM(203mm <sup>2</sup> )*2		RF300X00A
VFD2200CH43A-00	500MCM(253mm <sup>2</sup> )*2		RF300X00A
VFD1600CH43A-21	4/0AWG(107mm <sup>2</sup> )*2		RF300X00A
VFD1850CH43A-21	300MCM(152mm <sup>2</sup> )*2		RF300X00A

CH2000 Series	Mini. Wire Gauge (Cross Sectional Area)	Max. Wire Gauge(Diameter)	Recommended Zero Phase Reactor
VFD2200CH43A-21	400MCM(203mm <sup>2</sup> )*2		RF300X00A
VFD2800CH43A-00	4/0AWG(107mm <sup>2</sup> )*4	300MCM(13.91mm)*4	RF300X00A
VFD2800CH43C-00	3/0AWG(85mm <sup>2</sup> )*4		RF300X00A
VFD2800CH43C-21	3/0AWG(85mm <sup>2</sup> )*4		RF300X00A

Table 1.4.3-3 CH2000 series: recommended specifications for the zero-phase reactor

Zero Phase Reactor	RF002X00A	RF004X00A	RF008X00A	RF300X00A
Single-Phase Max. Wire Gauge	4/0 AWG	4 AWG	8 AWG	300 MCM*4

Table 1.4.3-4 Max. Wire Gauge of Zero Phase Reactor

## 1.5 Leakage current

Under normal operations of the frequency converter, part of the current flows to ground through PE. This current is leakage current. The value is affected by system voltage, motor frequency, motor type, PWM frequency of the frequency converter, and the length of input and output wires. It flows through the frequency converter, input and output wires and the motor-to-ground capacitance. In addition, the leakage current will affect other co-grounding system through ground wires. Therefore, the leakage current may cause malfunction of leakage circuit breaker or other sensors. This current may also harm the operators; therefore the relevant regulations are there to restrict the leakage current.

### 1.5.1 Precautions for leakage current

- 1.5.2.1 The closer the cable is to the ground, the greater the capacitance to the ground, and it will cause higher leakage current.
- 1.5.2.2 Using cables with lower ground capacitance can reduce the amount of leakage current.
- 1.5.2.3 Reducing the switch frequency of the frequency converter can reduce the amount of leakage current.
- 1.5.2.4 Using a zero-phase reactor at the input end can reduce the amount of leakage current.

### 1.5.2 Installation recommendations for the leakage circuit breaker.

- 1.5.2.1 The leakage circuit breaker should be installed between each frequency converter and the main power supply. The wiring diagram is shown in Figure 1.5.2-1.
- 1.5.2.2 Due to the pair of ground capacitance on each EMI filter, the leakage current will change accordingly.
- 1.5.2.3 Under high temperature or extreme low temperature conditions, non-electric leakage circuit breakers should be used.
- 1.5.2.4 The installation location of the leakage circuit breaker should be as far away from the charged conductor as possible, to avoid any malfunction caused by the magnetic field generated by the flow of large current passing through the conductor.

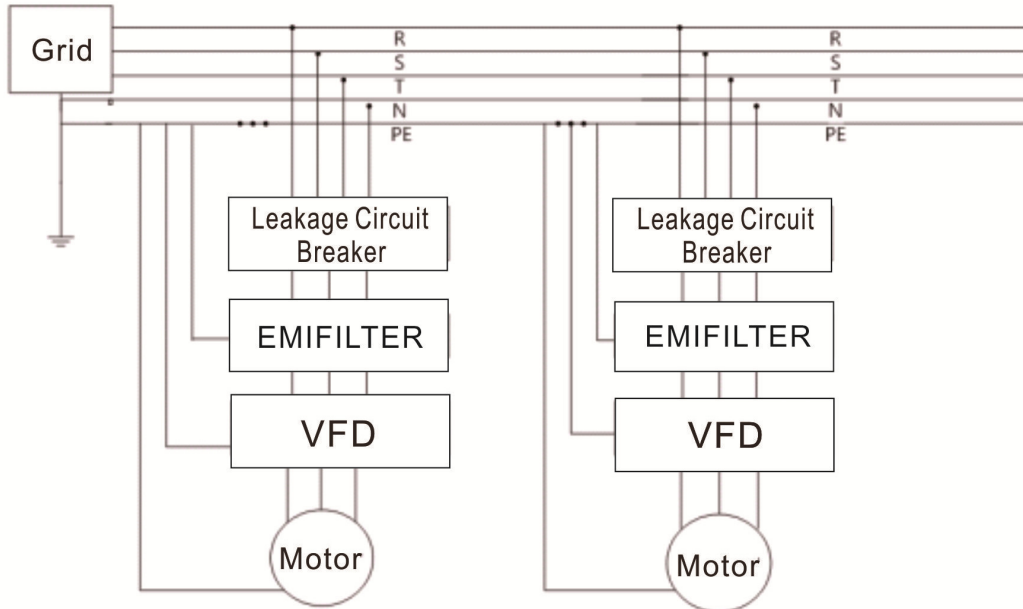

Figure 1.5.2-1: Wiring Diagram of Leakage Circuit Breaker

## 1.6 Wiring precautions

1.6.1 All power cables should be effectively divided and grouped according to its type, or isolated by the metal layer of the control cabinet. Please note that uninterrupted isolation should be kept between the two ends of the sensitive control wires. It is recommended to divide them into four classes (Ex: classes 1 to 4):

- i. Sensitive wires susceptible to interference (class 1), such as low-voltage high speed signal wire, control wire, data wire, etc.
- ii. Wires susceptible to interference, such as low speed communication wire, low-voltage (24V) power wire (class 2).
- iii. Interference wires (class 3), such as input wire of frequency converter (class 2).
- iv. Strong interference wires (class 4), such as output wire of frequency converter motor.

The recommended separation distances between the various wires are shown in the following figure.

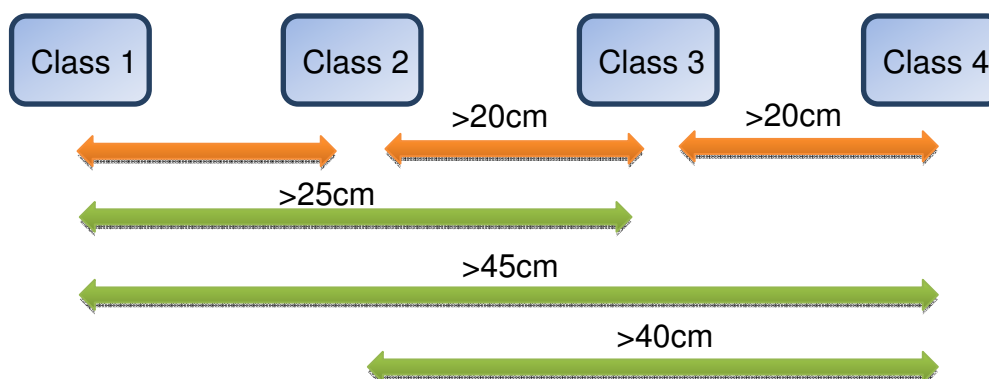

Figure 1.6.1-1: Classification of Motor's Cables



- 1.6.2 When the actual distance is unable to meet the requirements stated in 1.6.1, please connect a zero-phase reactor to the class 4 wire in series and use shielding wire on or a Core in series on the class 1 wire.
- 1.6.3 When the distance of different types of cables does not meet the requirements stated in 1.6.1-1, the cables should be placed orthogonally. For example, a filtered cable by a filter should be distanced from the unfiltered cable. The signal wires, data wires and filtered cables can only be placed orthogonally with unfiltered cables.

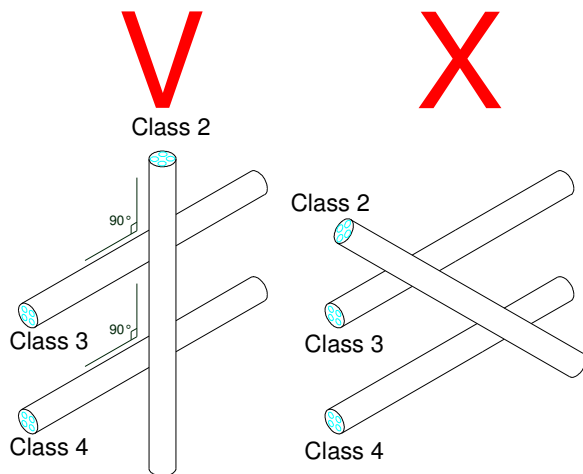

Figure 1.6.3-1: Placing signal cables & data cables.

- 1.6.4 All cables should be kept at the shortest length possible.
- 1.6.5 Please remove excess wires or ground them at both ends to avoid floating, as shown in Figure 1.6.5-1.

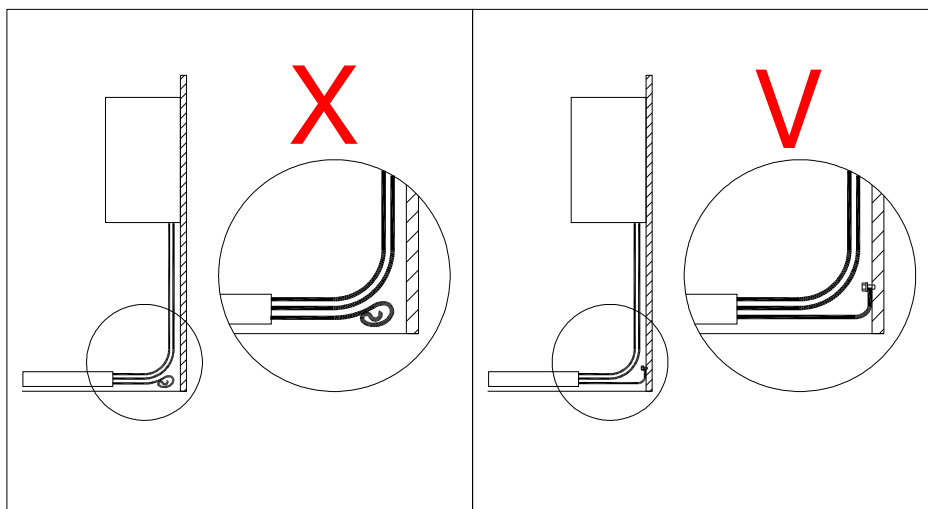

Figure 1.6.5-1: Grounding the both end of the excess wires to avoid floating.

- 1.6.6 The motor wire should be kept away from other data wires connected to the motor (encoder line or motor temperature sensors...).
- 1.6.7 Cables should not suspend in mid air. Place them flat on a metal surface if possible, as shown in Figure 1.6.7-1.

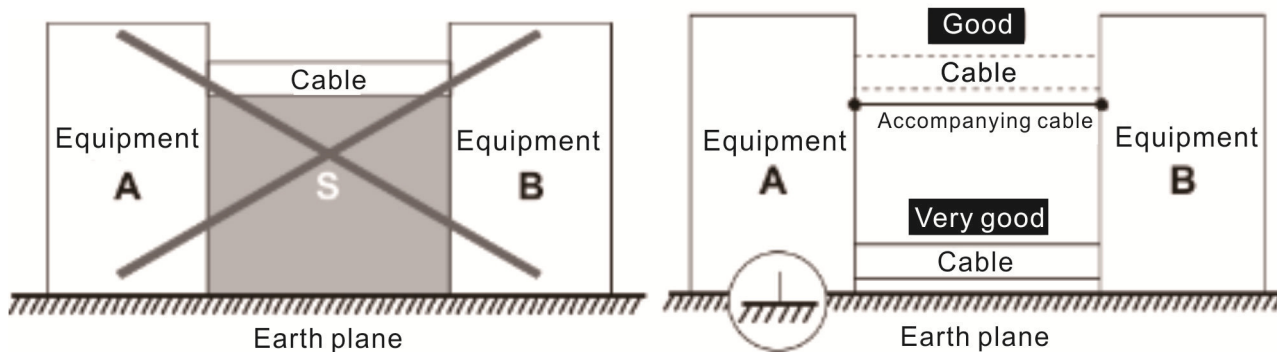

Figure 1.6.7-1: Placing cables flat on a metal surface.

- 1.6.8 For equipment susceptible to interference, it is recommended to separate the strong interference devices by an independent transformer, as shown in 1.6.8-1.

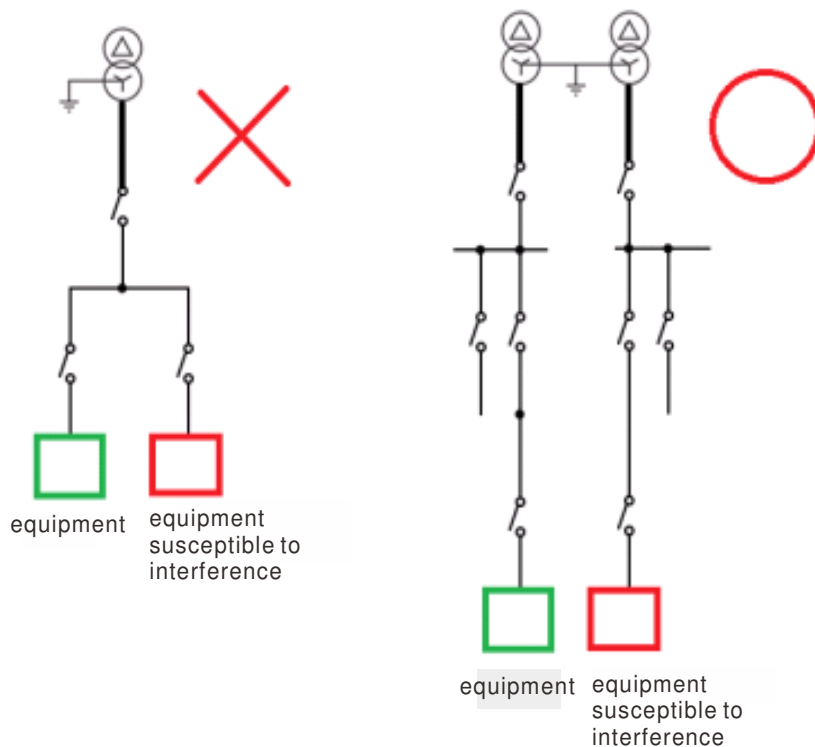

Figure 1.6.8-1 Separating equipment susceptible to interference

- 1.6.9 The coils of contactors, relays and solenoid valves must be equipped with RC filters to suppress the high frequency radiation interference when components are switched on and off (such as RC elements or varistors with AC coils and free-wheeling diodes or varistors for DC coils). These protective circuits must be connected near the coils.

## 1.7 Proper arrangements for housing and internal components

- 1.7.1 All metal casings, equipment and accessories (such as frequency converters or filters) installed in the cabinet must be connected to the frame of the control cabinet through a proper connection and pass through the largest surface area possible. The most ideal design is that the bare metal mounting plates installed on the equipment and accessories have good conductivity, and they are connected to the frame of the control cabinet through a good electrical connection as well as the largest surface area possible. Most importantly, they are all connected to PE and EMC isolation bars.
- 1.7.2 If the connection point of the metal casing is coated or anodized, it should be removed prior to connection or a special metal piece which goes through the non-conductive layer should be used, as shown in Figure 1.7.2-1, to establish a good connection.

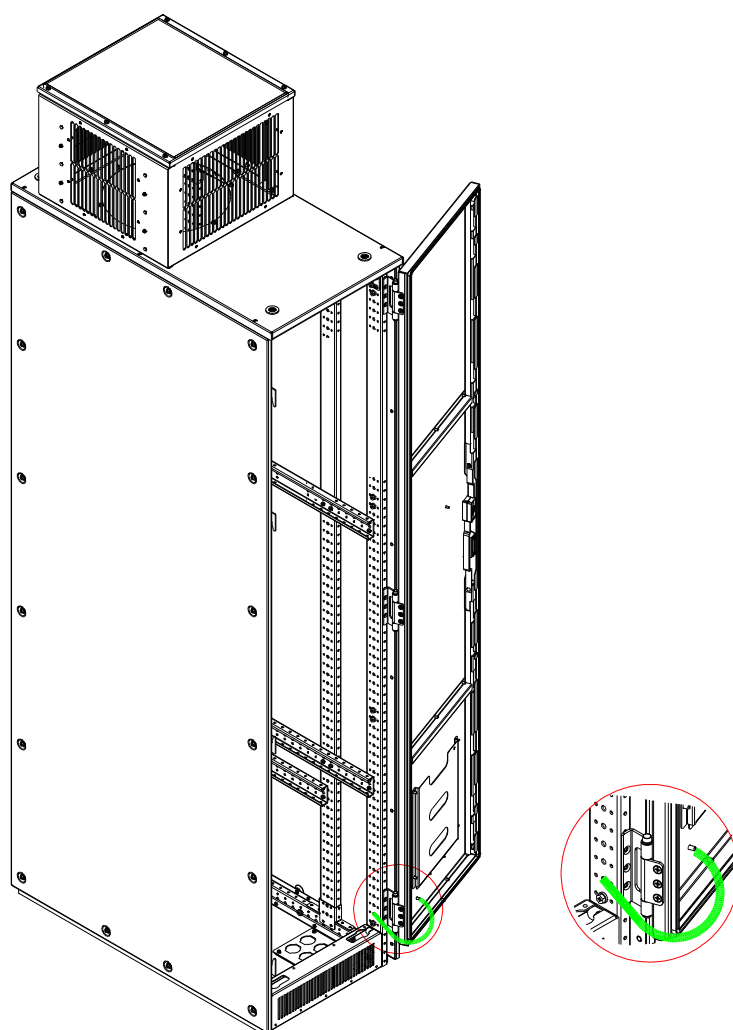

Figure 1.7.2-1

## 2. Harmonic:

In the electrical system, harmonic is low frequency interference. As long as there is non-linear load, there is a harmonic. For example, a diode in the frequency converter is a non-linear load.

The ideal current waveform is a sinusoidal pattern; Current with high harmonic will cause current distortion which makes the current become non-sinusoidal. As shown in Figure 6-1 below, (a) current waveform of linear load, (b) current waveform of non-linear load (rectifier diodes).

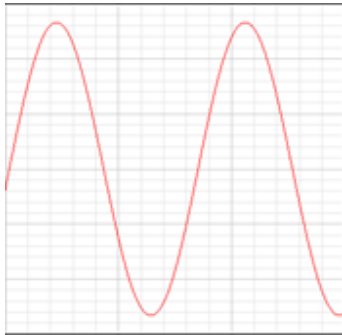

Figure 2-1(a)

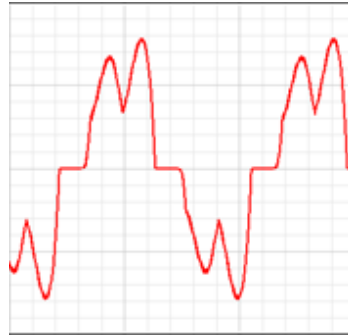

Figure 2-1(b)

If a non-linear load exists in the electrical system, such as a rectifier or electric arc furnace, high frequency current other than the fundamental frequency (60Hz) will be generated as well as harmonic pollution. Harmonic problems will shorten the life span of electric equipment, increase wear and tear of the electric grid and cause resonance issues. Installation of an AC\DC reactor can reduce harmonics. DELTA provides a series of standard reactors which when combined with DELTA frequency converters can effectively reduce harmonics and thus comply with regulatory standards.

### 2.1 Installation of AC\DC reactor

#### 2.1.1 Installation

AC input reactors are installed at the three-phase side of the main power supply, as shown in Figure 2.1.1-1 A DC reactor is installed at the DC P pole (Figure 2.1.1-2). For wiring terminals, please refer to the manual for DELTA frequency converter. For diameters of the installation wires, please refer to the manual for DELTA frequency converter.

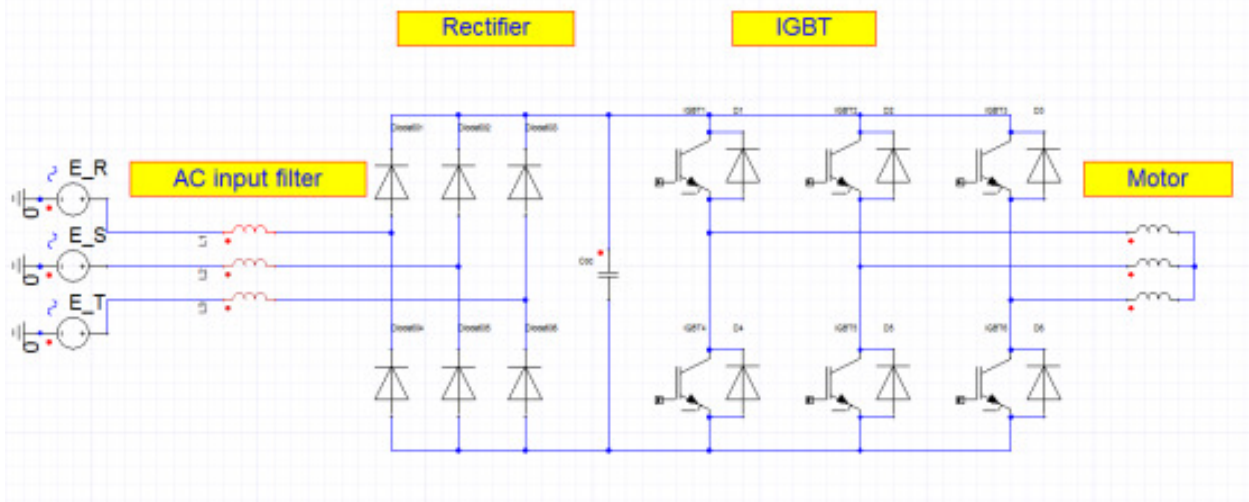

Figure 2.1.1-1 Intallation of AC Input Reactor

### Wiring Diagram for Frame A~C

\* It provides 3-phase power

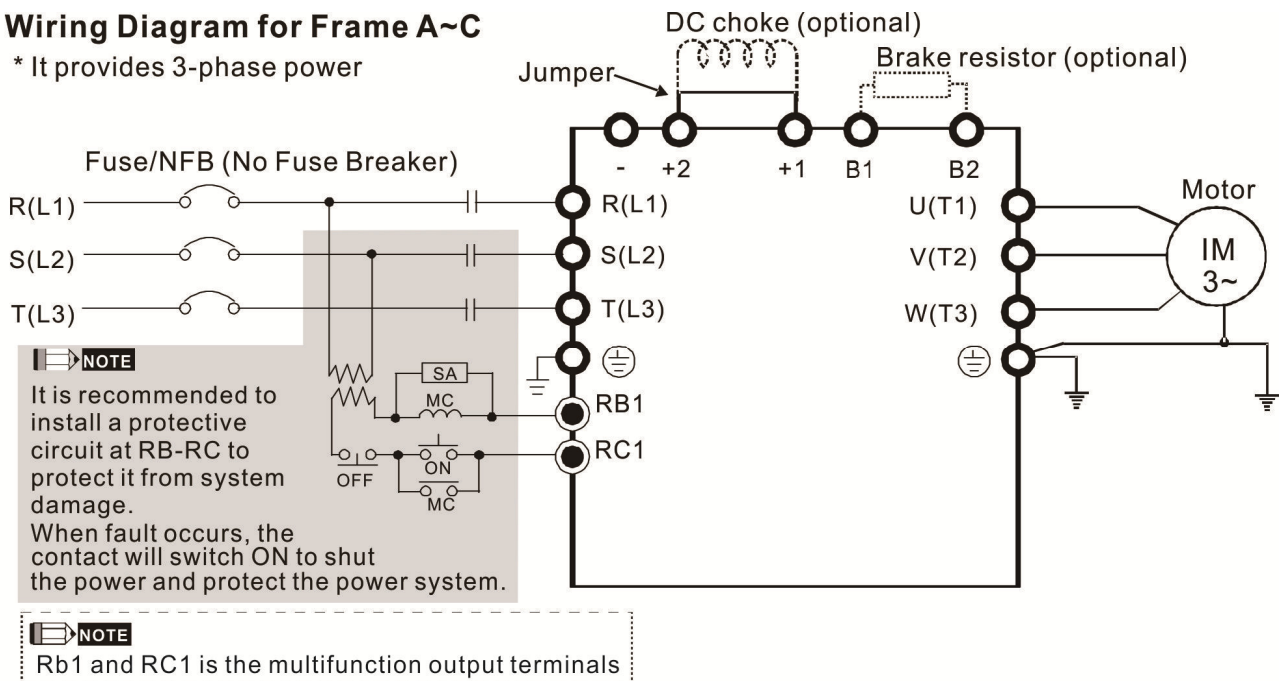

Figure 2.1.1-2

## 2.1.2 DELTA C/CP/CH series AC reactor specifications

The following table displays the DELTA C/CP/CH series AC reactor specifications

200V~230V/ 50~60Hz C series AC Input Reactors								
Type	KW	HP	Rated Amps of AC Reactor (Arms)	Max. Continuous Amp (Arms)	3% Impedance (mH)	5% Impedance (mH)	Built-in DC reactor	3% AC Input Reactor Delta part #
007	0.75	1	5	8.64	2.536	4.227	X	N/A
015	1.5	2	8	12.78	1.585	2.642	X	N/A
022	2.2	3	11	18	1.152	1.922	X	N/A
037	3.7	5	17	28.8	0.746	1.243	X	N/A
055	5.5	7.5	25	43.2	0.507	0.845	X	N/A
075	7.5	10	33	55.8	0.32	0.534	X	DR033AP320
110	11	15	49	84.6	0.216	0.359	X	DR049AP215
150	15	20	65	111.6	0.163	0.271	X	DR065AP162
185	18.5	25	75	127.8	0.169	0.282	X	N/A
220	22	30	90	154.8	0.141	0.235	X	N/A
300	30	40	120	205.2	0.106	0.176	O	N/A
370	37	50	146	250.2	0.087	0.145	O	N/A
450	45	60	180	307.8	0.070	0.117	O	N/A
550	55	75	215	367.2	0.059	0.098	O	N/A
750	75	100	255	435.6	0.049	0.083	O	N/A
900	90	125	346	592.2	0.037	0.061	O	N/A

Table 2.1.2-1: 200V~230V/ 50~60Hz C series AC Input Reactors

200V~230V/ 50~60Hz CP series AC Input Reactor													
Type	KW	HP	Rated Amps of AC Reactor (Arms)		Max. Continuous Amps (Arms)		3% Impedance (mH)		5% Impedance (mH)		Built-in DC reactor	3% AC Input Reactor Delta part#	
			Normal Duty	Light Duty	Normal Duty	Light Duty	Normal Duty	Light Duty	Normal Duty	Light Duty		Normal Duty	Light Duty
007	0.75	1	4.6	5	7.36	6	2.536	2.536	4.227	4.227	X	N/A	N/A
015	1.5	2	5	7.5	8	9	2.536	1.585	4.227	2.642	X	N/A	N/A
022	2.2	3	8	10	12.8	12	1.585	1.152	2.642	1.922	X	N/A	N/A
037	3.7	5	11	15	17.6	18	1.152	0.746	1.922	1.243	X	N/A	N/A
055	5.5	7.5	17	21	27.2	25.2	0.746	0.507	1.243	0.845	X	N/A	N/A
075	7.5	10	25	31	40	37.2	0.507	0.320	0.845	0.534	X	N/A	DR033AP320
110	11	15	33	46	52.8	55.2	0.320	0.216	0.534	0.359	X	DR033AP320	DR049AP215
150	15	20	49	61	78.4	73.2	0.216	0.163	0.359	0.271	X	DR049AP215	DR065AP162
185	18.5	25	65	75	104	90	0.163	0.147	0.271	0.282	X	DR065AP162	N/A
220	22	30	75	90	120	108	0.169	0.141	0.282	0.235	X	N/A	N/A
300	30	40	90	105	144	126	0.141	0.106	0.235	0.176	X	N/A	N/A
370	37	50	120	146	192	175.2	0.106	0.087	0.176	0.145	O	N/A	N/A
450	45	60	146	180	233.6	216	0.087	0.070	0.145	0.117	O	N/A	N/A
550	55	75	180	215	288	258	0.070	0.059	0.117	0.098	O	N/A	N/A
750	75	100	215	276	344	331.2	0.059	0.049	0.098	0.083	O	N/A	N/A
900	90	125	255	322	408	386.4	0.049	0.037	0.083	0.061	O	N/A	N/A

Table 2.1.2-2: 200V~230V/ 50~60Hz CP series AC Input Reactors

200V~230V/ 50~60Hz CH series AC Input Reactor									
Type	KW	HP	Rated Amps of AC Reactor (Arms)	Max. Continuous Amp (Arms)	3% Impedance (mH)	5% Impedance (mH)	Built-in DC reactor	3% AC Input Reactor Delta part #	
007	0.75	1	5	10	2.536	4.227	X	N/A	
015	1.5	2	8	16	1.585	2.642	X	N/A	
022	2.2	3	11	22	1.152	1.922	X	N/A	
037	3.7	5	17	34	0.746	1.243	X	N/A	
055	5.5	7.5	25	50	0.507	0.845	X	N/A	
075	7.5	10	33	66	0.320	0.534	X	DR033AP530	
110	11	15	49	98	0.216	0.359	X	DR049AP360	
150	15	20	65	130	0.163	0.271	X	DR065AP270	
185	18.5	25	75	150	0.169	0.282	X	N/A	
220	22	30	90	180	0.141	0.235	O	N/A	
300	30	40	120	240	0.106	0.176	O	N/A	
370	37	50	146	292	0.087	0.145	O	N/A	
450	45	60	180	360	0.070	0.117	O	N/A	
550	55	75	215	430	0.059	0.098	O	N/A	
750	75	100	255	510	0.049	0.083	O	N/A	

Table.2.1.2-3 200V~230V/ 50~60Hz CH series AC Input Reactor

380V~460V/ 50~60Hz C series AC Input Reactors								
Type	KW	HP	Rated Amps of AC Reactor (Arms)	Max. Continuous Amp (Arms)	3% Impedance (mH)	5% Impedance (mH)	Built-in DC reactor	3% AC Input Reactor Delta part #
007	0.75	1	3	5.22	8.102	13.502	X	N/A
015	1.5	2	4	6.84	6.077	10.127	X	N/A
022	2.2	3	6	10.26	4.050	6.752	X	N/A
037	3.7	5	9	14.58	2.700	4.501	X	N/A
040	4	5	10.5	17.1	2.315	3.858	X	N/A
055	5.5	7.5	12	19.8	2.025	3.375	X	N/A
075	7.5	10	18	30.6	1.174	1.957	X	DR018A0117
110	11	15	24	41.4	0.881	1.468	X	DR024AP880
150	15	20	32	54	0.66	1.101	X	DR032AP660
185	18.5	25	38	64.8	0.639	1.066	X	N/A
220	22	30	45	77.4	0.541	0.900	X	N/A
300	30	40	60	102.6	0.405	0.675	O	N/A
370	37	50	73	124.2	0.334	0.555	O	N/A
450	45	60	91	154.8	0.267	0.445	O	N/A
550	55	75	110	189	0.221	0.368	O	N/A
750	75	100	150	257.4	0.162	0.270	O	N/A
900	90	125	180	307.8	0.135	0.225	O	N/A
1100	110	150	220	376.2	0.110	0.184	O	N/A
1320	132	175	260	444.6	0.098	0.162	O	N/A
1600	160	215	310	531	0.078	0.131	O	N/A
1850	185	250	370	633.6	0.066	0.109	O	N/A
2200	220	300	460	786.6	0.054	0.090	O	N/A
2800	280	375	550	941.4	0.044	0.074	O	N/A
3150	315	420	616	1053	0.039	0.066	O	N/A
3550	355	475	683	1168.2	0.036	0.060	O	N/A
4500	450	600	866	1468.8	0.028	0.047	O	N/A

Table 2.1.2-4 380V~460V/ 50~60Hz C series AC Input Reactors



380V~460V/ 50~60Hz CP series AC Input Reactors													
Type	KW	HP	Rated Amps of AC Reactor (Arms)		Max. Continuous Amp (Arms)		3% Impedance (mH)		5% Impedance (mH)		Built-in DC reactor	3% AC Input Reactor Delta part#	
			Normal Duty	Light Duty	Normal Duty	Light Duty	Normal Duty	Light Duty	Normal Duty	Light Duty		Normal Duty	Light Duty
007	0.75	1	2.8	3	4.48	3.6	8.102	8.102	13.502	13.502	X	N/A	N/A
015	1.5	2	3	4.2	4.8	5.04	8.102	6.077	13.502	10.127	X	N/A	N/A
022	2.2	3	4	5.5	6.4	6.6	6.077	4.050	10.127	6.752	X	N/A	N/A
037	3.7	5	6	8.5	9.6	10.2	4.050	2.700	6.752	4.501	X	N/A	N/A
040	4	5	9	10.5	14.4	12.6	2.700	2.315	4.501	3.858	X	N/A	N/A
055	5.5	7.5	10.5	13	16.8	15.6	2.315	2.025	3.858	3.375	X	N/A	N/A
075	7.5	10	12	18	19.2	21.6	2.025	1.174	3.375	1.957	X	N/A	DR018A0117
110	11	15	18	24	28.8	28.8	1.174	0.881	1.957	1.468	X	DR018A0117	DR024AP880
150	15	20	24	32	38.4	38.4	0.881	0.660	1.468	1.101	X	DR024AP880	DR032AP660
185	18.5	25	32	38	51.2	45.6	0.660	0.639	1.101	1.066	X	DR032AP660	N/A
220	22	30	38	45	60.8	54	0.639	0.541	1.066	0.900	X	N/A	N/A
300	30	40	45	60	72	72	0.541	0.405	0.900	0.675	X	N/A	N/A
370	37	50	60	73	96	87.6	0.405	0.334	0.675	0.555	X	N/A	N/A
450	45	60	73	91	116.8	109.2	0.334	0.267	0.555	0.445	O	N/A	N/A
550	55	75	91	110	145.6	132	0.267	0.221	0.445	0.368	O	N/A	N/A
750	75	100	110	150	176	180	0.221	0.162	0.368	0.270	O	N/A	N/A
900	90	125	150	180	240	216	0.162	0.135	0.270	0.225	O	N/A	N/A
1100	110	150	180	220	288	264	0.135	0.110	0.225	0.184	O	N/A	N/A
1320	132	175	220	260	352	312	0.110	0.098	0.184	0.162	O	N/A	N/A
1600	160	215	260	310	416	372	0.098	0.078	0.162	0.131	O	N/A	N/A
1850	185	250	310	370	496	444	0.078	0.066	0.131	0.109	O	N/A	N/A
2200	220	300	370	460	592	552	0.066	0.054	0.109	0.090	O	N/A	N/A
2800	280	375	460	530	736	636	0.054	0.044	0.090	0.074	O	N/A	N/A
3150	315	420	550	616	880	739.2	0.044	0.039	0.074	0.066	O	N/A	N/A
3550	355	475	616	683	985.6	819.6	0.039	0.036	0.066	0.060	O	N/A	N/A
4000	400	536	683	770	1092.8	924	0.036	0.028	0.060	0.047	O	N/A	N/A
5000	500	675	866	912	1385.6	1094.4	0.028	0.028	0.047	0.047	O	N/A	N/A

Table2.1.2-5 380V~460V/ 50~60Hz CP series AC Input Reactors

380V~460V/ 50~60Hz CH series AC Input Reactors								
Type	KW	HP	Rated Amps of AC Reactor (Arms)	Max. Continuous Amp (Arms)	3% impedance (mH)	5% impedance (mH)	Built-in DC reactor	3% AC Input Reactor Delta part #
007	0.75	1	3	6	8.102	13.502	X	N/A
015	1.5	2	4	8	6.077	10.127	X	N/A
022	2.2	3	6	12	4.050	6.752	X	N/A
037	3.7	5	9	18	2.700	4.501	X	N/A
055	5.5	7.5	12	24	2.025	3.375	X	N/A
075	7.5	10	18	36	1.174	1.957	X	DR018A0117
110	11	15	24	48	0.881	1.468	X	DR024AP880
150	15	20	32	64	0.660	1.101	X	DR032AP660
185	18.5	25	38	76	0.639	1.066	X	N/A
220	22	30	45	90	0.541	0.900	X	N/A
300	30	40	60	120	0.405	0.675	X	N/A
370	37	50	73	146	0.334	0.555	O	N/A
450	45	60	91	182	0.267	0.445	O	N/A
550	55	75	110	220	0.221	0.368	O	N/A
750	75	100	150	300	0.162	0.270	O	N/A
900	90	125	180	360	0.135	0.225	O	N/A
1100	110	150	220	440	0.110	0.184	O	N/A
1320	132	175	250	500	0.098	0.162	O	N/A
1600	160	215	310	620	0.078	0.131	O	N/A
1850	185	250	370	740	0.066	0.109	O	N/A
2200	220	300	450	900	0.054	0.090	O	N/A
2800	280	375	550	1100	0.044	0.074	O	N/A

Table 2.1.2-6 380V~460V/ 50~60Hz CH series AC Input Reactors

The following table shows the standard specification of DC reactor.

200V~230V/ 50~60Hz C series DC Reactors						
Type	KW	HP	Rated Amps of (Arms)	Max .Continuous Amps(Arms)	4% DC impedance (mH)	4% DC Reactor Delta part#
007	0.75	1	5	8.64	5.857	N/A
015	1.5	2	8	12.78	3.660	N/A
022	2.2	3	11	18	2.662	N/A
037	3.7	5	17	28.8	1.722	N/A
055	5.5	7.5	25	43.2	1.172	N/A
075	7.5	10	33	55.8	0.851	N/A
110	11	15	49	84.6	0.574	N/A
150	15	20	65	111.6	0.432	N/A
185	18.5	25	75	127.8	0.391	N/A
220	22	30	90	154.8	0.325	N/A

Table 2.1.2-7 200V~230V/ 50~60Hz C series DC Reactors

200V~230V/ 50~60Hz CP series DC Reactors										
Type	KW	HP	Rated Amps (Arms)		Max. Continuous Amps (Arms)		DC impedance (mH)		DC Reactor Delta Part #	
			Normal Duty	Light Duty	Normal Duty	Light Duty	Normal Duty	Light Duty	Normal Duty	Light Duty
007	0.75	1	4.6	5	7.36	6	5.857	5.857	N/A	N/A
015	1.5	2	5	7.5	8	9	5.857	3.660	N/A	N/A
022	2.2	3	8	10	12.8	12	3.660	2.662	N/A	N/A
037	3.7	5	11	15	17.6	18	2.662	1.722	N/A	N/A
055	5.5	7.5	17	21	27.2	25.2	1.722	1.172	N/A	N/A
075	7.5	10	25	31	40	37.2	1.172	0.851	N/A	N/A
110	11	15	33	46	52.8	55.2	0.851	0.574	N/A	N/A
150	15	20	49	61	78.4	73.2	0.574	0.432	N/A	N/A
185	18.5	25	65	75	104	90	0.432	0.391	N/A	N/A
220	22	30	75	90	120	108	0.391	0.325	N/A	N/A
300	30	40	90	105	144	126	0.325	0.244	N/A	N/A

Table 2.1.2-8 200V~230V/ 50~60Hz CP series DC Reactors

200V~230V/ 50~60Hz CH series DC Reactors						
Type	KW	HP	Rated Amps (Arms)	Max. Continuous Amps (Arms)	DC Impedance (mH)	DC Reactor Delta Part #
007	0.75	1	5	10	5.857	N/A
015	1.5	2	8	16	3.660	N/A
022	2.2	3	11	22	2.662	N/A
037	3.7	5	17	34	1.722	N/A
055	5.5	7.5	25	50	1.172	N/A
075	7.5	10	33	66	0.851	N/A
110	11	15	49	98	0.574	N/A
150	15	20	65	130	0.432	N/A
185	18.5	25	75	150	0.391	N/A

Table 2.1.2-9 200V~230V/ 50~60Hz CH series DC reactors

380V~460V/ 50~60Hz C series DC Input Reactors						
Type	KW	HP	Rated Amps (Arms)	Max. Continuous Amps (Arms)	DC Impedance (mH)	DC Reactor Delta Part #
007	0.75	1	3	5.22	18.709	N/A
015	1.5	2	4	6.84	14.031	N/A
022	2.2	3	6	10.26	9.355	N/A
037	3.7	5	9	14.58	6.236	N/A
040	4	5	10.5	17.1	5.345	N/A
055	5.5	7.5	12	19.8	4.677	N/A
075	7.5	10	18	30.6	3.119	N/A
110	11	15	24	41.4	2.338	N/A
150	15	20	32	54	1.754	N/A
185	18.5	25	38	64.8	1.477	N/A
220	22	30	45	77.4	1.247	N/A

Table 2.1.2-10 380V~460V/ 50~60Hz C series DC Reactors

380V~460V/ 50~60Hz CP series DC Reactors										
Type	KW	HP	Rated Amps (Arms)		Max. Continuous Amps (Arms)		DC Impedance (mH)		DC Reactor Delta Part #	
			Normal Duty	Light Duty	Normal Duty	Light Duty	Normal Duty	Light Duty	Normal Duty	Light Duty
007	0.75	1	2.8	3	4.48	3.6	18.709	18.709	N/A	N/A
015	1.5	2	3	4.2	4.8	5.04	18.709	14.031	N/A	N/A
022	2.2	3	4	5.5	6.4	6.6	14.031	9.355	N/A	N/A
037	3.7	5	6	8.5	9.6	10.2	9.355	6.236	N/A	N/A
040	4	5	9	10.5	14.4	12.6	6.236	5.345	N/A	N/A
055	5.5	7.5	10.5	13	16.8	15.6	5.345	4.677	N/A	N/A
075	7.5	10	12	18	19.2	21.6	4.677	3.119	N/A	N/A
110	11	15	18	24	28.8	28.8	3.119	2.338	N/A	N/A
150	15	20	24	32	38.4	38.4	2.338	1.754	N/A	N/A
185	18.5	25	32	38	51.2	45.6	1.754	1.477	N/A	N/A
220	22	30	38	45	60.8	54	1.477	1.247	N/A	N/A
300	30	40	45	60	72	72	1.247	0.935	N/A	N/A
370	37	50	60	73	96	87.6	0.935	0.768	N/A	N/A

Table 2.1.2-11 380V~460V/ 50~60Hz CP series DC Reactors

380V~460V/ 50~60Hz CH series DC Reactors						
Type	KW	HP	Rated Amps (Arms)	Max. Continuous Amps (Arms)	DC Impedance (mH)	DC Reactor Delta Part #
007	0.75	1	3	6	18.709	N/A
015	1.5	2	4	8	14.031	N/A
022	2.2	3	6	12	9.355	N/A
037	3.7	5	9	18	6.236	N/A
055	5.5	7.5	12	24	4.677	N/A
075	7.5	10	18	36	3.119	N/A
110	11	15	24	48	2.338	N/A
150	15	20	32	64	1.754	N/A
185	18.5	25	38	76	1.477	N/A
220	22	30	45	90	1.247	N/A
300	30	40	60	120	0.935	N/A

Table 2.1.2-12 380V~460V/ 50~60Hz CH series DC Reactor

### 2.1.3 Specifications of THDi after an AC/DC reactor is combined with DELTA frequency converter

The following table shows the specifications of THDi after an AC/DC reactor is combined with the DELTA frequency converter.

VFD specifications	VFD w/o AC/DC Reactors	VFD w/o built-in DC Reactor			VFD with built-in DC Reactors	
Series Reactors specifications		3% Input AC Reactor	5% Input AC Reactor	4% DC Reactor	3% Input AC Reactor	5% Input AC Reactor
5th	73.3%	38.5%	30.8%	25.5%	27.01%	25.5%
7th	52.74%	15.3%	9.4%	18.6%	9.54%	8.75%
11th	7.28%	7.1%	6.13%	7.14%	4.5%	4.2%
13th	0.4%	3.75%	3.15%	0.48%	0.22%	0.17%
THDi	91%	43.6%	34.33%	38.2%	30.5%	28.4%
Note:	THDi will be slightly different due to different installation and environmental conditions (such as cables and motors).					

Table 2.1.3-1 THDi Specifications

### 3. Output reactor

Under the condition of long output wires, GF (Ground Fault), OC (Over Current) and motor voltage overshoot often occur within the drive. The first two will cause errors which are due to the protective mechanisms of the drive, and voltage overshoot will cause damage to the insulation of the motor.

Excessively long output wire leads to excessive ground stray capacitance and thus increases the current of three-phase output common mode; GF is triggered as a failsafe mechanism to protect the drive. In addition, the wire-to-wire and wire-to-ground stray capacitance is increased, causing an inrush current which triggers OC protection due to excessive current output of the drive. Usually a reactor is installed at the drive side to increase the high frequency impedance so that the current is decreased due to stray capacitance.

#### 3.1 Installation of output reactor

AC output reactor is placed in the output side of the drive, as shown in figure below. Please refer to the C2000 manual for the proper diameters of the installation wires.

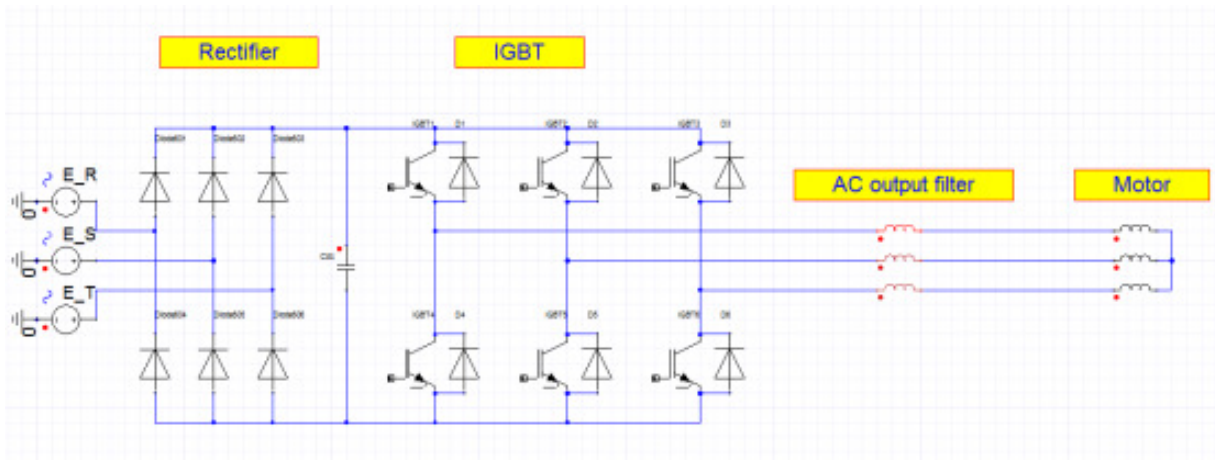

Figure 3.1-1 Intallation of Output Reactor

### 3.2 Specification of size

The following table contains DELTA C/CP/CH series output reactor specifications

200V~230V/ 50~60Hz C series Output AC Reactors								
Type	KW	HP	Rated Amps (Arms)	Max. Continuous Amps (Arms)	3% Reactor (mH)	5% Reactor (mH)	Built-in DC Reactor	3% Output Reactor Delta Part #
007	0.75	1	5	8.64	2.536	4.227	X	N/A
015	1.5	2	8	12.78	1.585	2.642	X	N/A
022	2.2	3	11	18	1.152	1.922	X	N/A
037	3.7	5	17	28.8	0.746	1.243	X	N/A
055	5.5	7.5	25	43.2	0.507	0.845	X	N/A
075	7.5	10	33	55.8	0.32	0.534	X	N/A
110	11	15	49	84.6	0.216	0.359	X	N/A
150	15	20	65	111.6	0.163	0.271	X	N/A
185	18.5	25	75	127.8	0.169	0.282	X	N/A
220	22	30	90	154.8	0.141	0.235	X	N/A
300	30	40	120	205.2	0.106	0.176	O	N/A
370	37	50	146	250.2	0.087	0.145	O	N/A
450	45	60	180	307.8	0.070	0.117	O	N/A
550	55	75	215	367.2	0.059	0.098	O	N/A
750	75	100	255	435.6	0.049	0.083	O	N/A
900	90	125	346	592.2	0.037	0.061	O	N/A

Table 3.2-1 .200V~230V/ 50~60Hz C series Output AC Reactors

200V~230V/ 50~60Hz CP series Output AC Reactors													
Type	KW	HP	Rated Amps (Arms)		Max. Continuous Amps (Arms)		3% Reactor (mH)		5% Reactor (mH)		Built-in DC Reactor	3% Output Reactor Delta Part #	
			Normal Duty	Light Duty	Normal Duty	Light Duty	Normal Duty	Light Duty	Normal Duty	Light Duty		Normal Duty	Light Duty
007	0.75	1	4.6	5	7.36	6	2.536	2.536	4.227	4.227	X	N/A	N/A
015	1.5	2	5	7.5	8	9	2.536	1.585	4.227	2.642	X	N/A	N/A
022	2.2	3	8	10	12.8	12	1.585	1.152	2.642	1.922	X	N/A	N/A
037	3.7	5	11	15	17.6	18	1.152	0.746	1.922	1.243	X	N/A	N/A
055	5.5	7.5	17	21	27.2	25.2	0.746	0.507	1.243	0.845	X	N/A	N/A
075	7.5	10	25	31	40	37.2	0.507	0.320	0.845	0.534	X	N/A	N/A
110	11	15	33	46	52.8	55.2	0.320	0.216	0.534	0.359	X	N/A	N/A
150	15	20	49	61	78.4	73.2	0.216	0.163	0.359	0.271	X	N/A	N/A
185	18.5	25	65	75	104	90	0.163	0.147	0.271	0.282	X	N/A	N/A
220	22	30	75	90	120	108	0.169	0.141	0.282	0.235	X	N/A	N/A
300	30	40	90	105	144	126	0.141	0.106	0.235	0.176	X	N/A	N/A



200V~230V/ 50~60Hz CP series Output AC Reactors													
Type	KW	HP	Rated Amps (Arms)		Max. Continuous Amps (Arms)		3% Reactor (mH)		5% Reactor (mH)		Built-in DC Reactor	3% Output Reactor Delta Part #	
			Normal Duty	Light Duty	Normal Duty	Light Duty	Normal Duty	Light Duty	Normal Duty	Light Duty		Normal Duty	Light Duty
370	37	50	120	146	192	175.2	0.106	0.087	0.176	0.145	O	N/A	N/A
450	45	60	146	180	233.6	216	0.087	0.070	0.145	0.117	O	N/A	N/A
550	55	75	180	215	288	258	0.070	0.059	0.117	0.098	O	N/A	N/A
750	75	100	215	276	344	331.2	0.059	0.049	0.098	0.083	O	N/A	N/A
900	90	125	255	322	408	386.4	0.049	0.037	0.083	0.061	O	N/A	N/A

Table 3.2-2 200V~230V/ 50~60Hz CP series AC Output Reactors

200V~230V/ 50~60Hz CH series AC Output Reactor									
Type	KW	HP	Rated Amps (Arms)	Max. Continuous Amps (Arms)	3% Reactor (mH)	5% Reactor (mH)	Built-In DC Reactor	3% Output Reactor Delta Part #	
007	0.75	1	5	10	2.536	4.227	X	N/A	
015	1.5	2	8	16	1.585	2.642	X	N/A	
022	2.2	3	11	22	1.152	1.922	X	N/A	
037	3.7	5	17	34	0.746	1.243	X	N/A	
055	5.5	7.5	25	50	0.507	0.845	X	N/A	
075	7.5	10	33	66	0.320	0.534	X	N/A	
110	11	15	49	98	0.216	0.359	X	N/A	
150	15	20	65	130	0.163	0.271	X	N/A	
185	18.5	25	75	150	0.169	0.282	X	N/A	
220	22	30	90	180	0.141	0.235	O	N/A	
300	30	40	120	240	0.106	0.176	O	N/A	
370	37	50	146	292	0.087	0.145	O	N/A	
450	45	60	180	360	0.070	0.117	O	N/A	
550	55	75	215	430	0.059	0.098	O	N/A	
750	75	100	255	510	0.049	0.083	O	N/A	

Table 3.2-3 200V~230V/ 50~60Hz CH series AC Output Reactor

380V~460V/ 50~60Hz C series AC Output Reactor								
Type	KW	HP	Rated Amps (Arms)	Max. Continuous Amps (Arms)	3% Reactor (mH)	5% Reactor (mH)	Built-In DC Reactor	3% Output Reactor Delta Part #
007	0.75	1	3	5.22	8.102	13.502	X	N/A
015	1.5	2	4	6.84	6.077	10.127	X	N/A
022	2.2	3	6	10.26	4.050	6.752	X	N/A
037	3.7	5	9	14.58	2.700	4.501	X	N/A
040	4	5	10.5	17.1	2.315	3.858	X	N/A
055	5.5	7.5	12	19.8	2.025	3.375	X	N/A
075	7.5	10	18	30.6	1.174	1.957	X	N/A
110	11	15	24	41.4	0.881	1.468	X	N/A
150	15	20	32	54	0.66	1.101	X	N/A
185	18.5	25	38	64.8	0.639	1.066	X	N/A
220	22	30	45	77.4	0.541	0.900	X	N/A
300	30	40	60	102.6	0.405	0.675	O	N/A
370	37	50	73	124.2	0.334	0.555	O	N/A
450	45	60	91	154.8	0.267	0.445	O	N/A
550	55	75	110	189	0.221	0.368	O	N/A
750	75	100	150	257.4	0.162	0.270	O	N/A
900	90	125	180	307.8	0.135	0.225	O	N/A
1100	110	150	220	376.2	0.110	0.184	O	N/A
1320	132	175	260	444.6	0.098	0.162	O	N/A
1600	160	215	310	531	0.078	0.131	O	N/A
1850	185	250	370	633.6	0.066	0.109	O	N/A
2200	220	300	460	786.6	0.054	0.090	O	N/A
2800	280	375	550	941.4	0.044	0.074	O	N/A
3150	315	420	616	1053	0.039	0.066	O	N/A
3550	355	475	683	1168.2	0.036	0.060	O	N/A
4500	450	600	866	1468.8	0.028	0.047	O	N/A

Table 3.2-4 380V~460V/ 50~60Hz C Series Output AC Reactor

380V~460V/ 50~60Hz CP Series AC Output Reactor													
Type	KW	HP	Rated Amps (Arms)		Max. Continuous Amps (Arms)		3% Reactor (mH)		5% Reactor (mH)		Built-In DC Reactor	3% Output Reactor Delta Part #	
			Normal Duty	Light Duty	Normal Duty	Light Duty	Normal Duty	Light Duty	Normal Duty	Light Duty		Normal Duty	Light Duty
007	0.75	1	2.8	3	4.48	3.6	8.102	8.102	13.502	13.502	X	N/A	N/A
015	1.5	2	3	4.2	4.8	5.04	8.102	6.077	13.502	10.127	X	N/A	N/A
022	2.2	3	4	5.5	6.4	6.6	6.077	4.050	10.127	6.752	X	N/A	N/A
037	3.7	5	6	8.5	9.6	10.2	4.050	2.700	6.752	4.501	X	N/A	N/A
040	4	5	9	10.5	14.4	12.6	2.700	2.315	4.501	3.858	X	N/A	N/A
055	5.5	7.5	10.5	13	16.8	15.6	2.315	2.025	3.858	3.375	X	N/A	N/A
075	7.5	10	12	18	19.2	21.6	2.025	1.174	3.375	1.957	X	N/A	N/A
110	11	15	18	24	28.8	28.8	1.174	0.881	1.957	1.468	X	N/A	N/A
150	15	20	24	32	38.4	38.4	0.881	0.660	1.468	1.101	X	N/A	N/A
185	18.5	25	32	38	51.2	45.6	0.660	0.639	1.101	1.066	X	N/A	N/A
220	22	30	38	45	60.8	54	0.639	0.541	1.066	0.900	X	N/A	N/A
300	30	40	45	60	72	72	0.541	0.405	0.900	0.675	X	N/A	N/A
370	37	50	60	73	96	87.6	0.405	0.334	0.675	0.555	X	N/A	N/A
450	45	60	73	91	116.8	109.2	0.334	0.267	0.555	0.445	O	N/A	N/A
550	55	75	91	110	145.6	132	0.267	0.221	0.445	0.368	O	N/A	N/A
750	75	100	110	150	176	180	0.221	0.162	0.368	0.270	O	N/A	N/A
900	90	125	150	180	240	216	0.162	0.135	0.270	0.225	O	N/A	N/A
1100	110	150	180	220	288	264	0.135	0.110	0.225	0.184	O	N/A	N/A
1320	132	175	220	260	352	312	0.110	0.098	0.184	0.162	O	N/A	N/A
1600	160	215	260	310	416	372	0.098	0.078	0.162	0.131	O	N/A	N/A
1850	185	250	310	370	496	444	0.078	0.066	0.131	0.109	O	N/A	N/A
2200	220	300	370	460	592	552	0.066	0.054	0.109	0.090	O	N/A	N/A
2800	280	375	460	530	736	636	0.054	0.044	0.090	0.074	O	N/A	N/A
3150	315	420	550	616	880	739.2	0.044	0.039	0.074	0.066	O	N/A	N/A
3550	355	475	616	683	985.6	819.6	0.039	0.036	0.066	0.060	O	N/A	N/A
4000	400	536	683	770	1092.8	924	0.036	0.028	0.060	0.047	O	N/A	N/A
5000	500	675	866	912	1385.6	1094.4	0.028	0.028	0.047	0.047	O	N/A	N/A

Table 3.2-5 380V~460V/ 50~60Hz CP Series AC Output Reactor

380V~460V/ 50~60Hz CH Series AC Output Reactor								
Type	KW	HP	Rated Amps (Arms)	Max. Continuous Amps (Arms)	3% Reactor (mH)	5% Reactor (mH)	Built-In DC Reactor	3% Output Reactor Delta Part #
007	0.75	1	3	6	8.102	13.502	X	N/A
015	1.5	2	4	8	6.077	10.127	X	N/A
022	2.2	3	6	12	4.050	6.752	X	N/A
037	3.7	5	9	18	2.700	4.501	X	N/A
055	5.5	7.5	12	24	2.025	3.375	X	N/A
075	7.5	10	18	36	1.174	1.957	X	N/A
110	11	15	24	48	0.881	1.468	X	N/A
150	15	20	32	64	0.660	1.101	X	N/A
185	18.5	25	38	76	0.639	1.066	X	N/A
220	22	30	45	90	0.541	0.900	X	N/A
300	30	40	60	120	0.405	0.675	X	N/A
370	37	50	73	146	0.334	0.555	O	N/A
450	45	60	91	182	0.267	0.445	O	N/A
550	55	75	110	220	0.221	0.368	O	N/A
750	75	100	150	300	0.162	0.270	O	N/A
900	90	125	180	360	0.135	0.225	O	N/A
1100	110	150	220	440	0.110	0.184	O	N/A
1320	132	175	250	500	0.098	0.162	O	N/A
1600	160	215	310	620	0.078	0.131	O	N/A
1850	185	250	370	740	0.066	0.109	O	N/A
2200	220	300	450	900	0.054	0.090	O	N/A
2800	280	375	550	1100	0.044	0.074	O	N/A

Table 3.2-6 380V~460V/ 50~60Hz CH Series Output AC Reactor

### 3.3 Output reactor and the length of output wire

Figures 3.3-1 & 3.3-2 are the experimental results of dV/dt and the motor terminal voltage after adding AC output reactors. The objective is to see the impacts dV/dt and motor terminal voltage have on the length of wire and output reactor.

When the output reactor is added, the impedance will increase which lowers the overall dV/dt. As the length of the wire increases, the impedance increases, and dV/dt decreases. Meanwhile, the increase in impedance reduces the wave peak of voltage reflection, which in turn reduces the voltage of motor terminal. Since voltages for both dV/dt and the motor terminal decreased, it increases the length of the output motor wire.

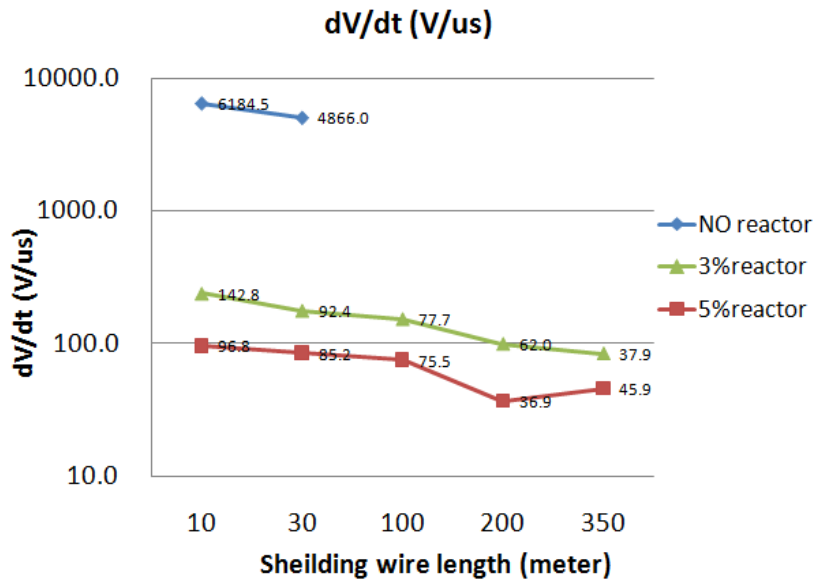

Figure 3.3-1 Experimental results of dV/ dt on the terminal voltage & length of wire

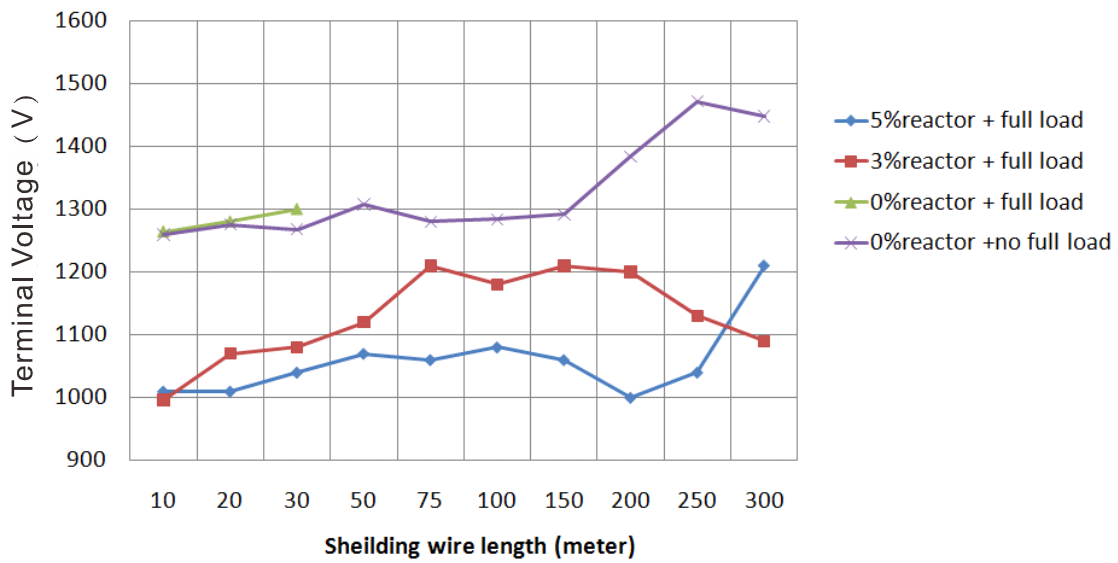

Figure 3.3-2 Experimental results of terminal voltage on the length of wire

C2000 220V Models Maximum Cable Length							
Models of 220V	KW	HP	Rated Amps	Without Output Choke		With Output Choke	
			(Arms)	Shielded Cable (meter)	Unshielded Cable (meter)	Shielded Cable (meter)	Unshielded Cable (meter)
7	0.75	1	5	50	75	75	115
15	1.5	2	8	50	75	75	115
22	2.2	3	11	50	75	75	115
37	3.7	5	17	50	75	75	115
55	5.5	7.5	25	50	75	75	115
75	7.5	10	33	100	150	150	225
110	11	15	49	100	150	150	225
150	15	20	65	100	150	150	225
185	18.5	25	75	100	150	150	225
220	22	30	90	100	150	150	225
300	30	40	120	100	150	150	225
370	37	50	146	100	150	150	225
450	45	60	180	150	225	225	325
550	55	75	215	150	225	225	325
750	75	100	255	150	225	225	325
900	90	125	346	150	225	225	325

Table 3.3-1 C2000 220V Models Output Reactors & Maximum Cable Length

C2000 440V Models Maximum Cable Length							
Models of 440V	KW	HP	Rated Amps	Without Output Choke		With Output Choke	
			(Arms)	Shielded Cable (meter)	Unshielded Cable (meter)	Shielded Cable (meter)	Unshielded Cable (meter)
007	0.75	1	3	50	75	75	115
15	1.5	2	4	50	75	75	115
22	2.2	3	6	50	75	75	115
37	3.7	5	9	50	75	75	115
40	4	5	10.5	50	75	75	115
55	5.5	7.5	12	50	75	75	115
75	7.5	10	18	100	150	150	225
110	11	15	24	100	150	150	225
150	15	20	32	100	150	150	225
185	18.5	25	38	100	150	150	225

C2000 440V Models Maximum Cable Length							
Models of 440V	KW	HP	Rated Amps	Without Output Choke		With Output Choke	
			(Arms)	Shielded Cable (meter)	Unshielded Cable (meter)	Shielded Cable (meter)	Unshielded Cable (meter)
220	22	30	45	100	150	150	225
300	30	40	60	100	150	150	225
370	37	50	73	100	150	150	225
450	45	60	91	150	225	225	325
550	55	75	110	150	225	225	325
750	75	100	150	150	225	225	325
900	90	125	180	150	225	225	325
1100	110	150	220	150	225	225	325
1320	132	175	260	150	225	225	325
1600	160	215	310	150	225	225	325
1850	185	250	370	150	225	225	325
2200	220	300	460	150	225	225	325
2800	280	375	550	150	225	225	325
3150	315	420	616	150	225	225	325
3550	355	475	683	150	225	225	325
4500	450	600	866	150	225	225	325

Table 3.3-2 C2000 440V Models Output Reactors & Maximum Cable Length

CP2000 220V Models Maximum Cable Length								
Models of 220V	KW	HP	Rated Amps (Arms)		Without Output Choke		With Output Choke	
			Normal Duty	Light Duty	Shielded Cable	Unshielded Cable	Shielded Cable	Unshielded Cable
007	0.75	1	4.6	5	50	75	75	115
015	1.5	2	5	7.5	50	75	75	115
022	2.2	3	8	10	50	75	75	115
037	3.7	5	11	15	50	75	75	115
040	5.5	7.5	17	21	50	75	75	115
055	7.5	10	25	31	100	150	150	225
075	11	15	33	46	100	150	150	225
150	15	20	49	61	100	150	150	225
185	18.5	25	65	75	100	150	150	225
220	22	30	75	90	100	150	150	225
300	30	40	90	105	100	150	150	225
370	37	50	120	146	100	150	150	225
450	45	60	146	180	150	225	225	325

CP2000 220V Models Maximum Cable Length								
Models of 220V	KW	HP	Rated Amps (Arms)		Without Output Choke		With Output Choke	
			Normal Duty	Light Duty	Shielded Cable	Unshielded Cable	Shielded Cable	Unshielded Cable
550	55	75	180	215	150	225	225	325
750	75	100	215	276	150	225	225	325
900	90	125	255	322	150	225	225	325

Table 3.3-3 CP2000 220V Models Output Reactor & Maximum Cable Length

CP2000 440V Models Maximum Cable Length								
Models of 440V	KW	HP	Rated Amps (Arms)		Without Output Choke		With Output Choke	
			Normal Duty	Light Duty	Shielded Cable	Unshielded Cable	Shielded Cable	Unshielded Cable
007	0.75	1	2.8	3	50	75	75	115
015	1.5	2	3	4.2	50	75	75	115
022	2.2	3	4	5.5	50	75	75	115
037	3.7	5	6	8.5	50	75	75	115
040	4	5	9	10.5	50	75	75	115
055	5.5	7.5	10.5	13	50	75	75	115
075	7.5	10	12	18	100	150	150	225
110	11	15	18	24	100	150	150	225
150	15	20	24	32	100	150	150	225
185	18.5	25	32	38	100	150	150	225
220	22	30	38	45	100	150	150	225
300	30	40	45	60	100	150	150	225
370	37	50	60	73	100	150	150	225
450	45	60	73	91	150	225	225	325
550	55	75	91	110	150	225	225	325
750	75	100	110	150	150	225	225	325
900	90	125	150	180	150	225	225	325
1100	110	150	180	220	150	225	225	325
1320	132	175	220	260	150	225	225	325
1600	160	215	260	310	150	225	225	325
1850	185	250	310	370	150	225	225	325
2200	220	300	370	460	150	225	225	325
2800	280	375	460	530	150	225	225	325
3150	315	420	550	616	150	225	225	325
3550	355	475	616	683	150	225	225	325
4000	400	536	683	770	150	225	225	325
5000	500	675	866	912	150	225	225	325



Table 3.3-4 CP2000 440V Models Output Reactor & Maximum Cable Length

CH2000 220V Models Maximum Cable Length							
Models of 220V	KW	HP	Rated Amps (Arms)	Without Output Choke		With Output Choke	
				Shielded Cable	Unshielded Cable	Shielded Cable	unshielded Cable
007	0.75	1	5	50	75	75	115
015	1.5	2	8	50	75	75	115
022	2.2	3	11	50	75	75	115
037	3.7	5	17	50	75	75	115
055	5.5	7.5	25	50	75	75	115
075	7.5	10	33	100	150	150	225
110	11	15	49	100	150	150	225
150	15	20	65	100	150	150	225
185	18.5	25	75	100	150	150	225
220	22	30	90	100	150	150	225
300	30	40	120	100	150	150	225
370	37	50	146	100	150	150	225
450	45	60	180	150	225	225	325
550	55	75	215	150	225	225	325
750	75	100	255	150	225	225	325

Table 3.3-5 CH2000 220V Models Output Reactors & Maximum Cable Length

CH2000 440V Models Maximum Cable Length							
Models of 440V	KW	HP	Rated Amps (Arms)	Without Output Choke		With Output Choke	
				Shielded Cable	Unshielded Cable	Shielded Cable	Unshielded Cable
007	0.75	1	3	50	75	75	115
015	1.5	2	4	50	75	75	115
022	2.2	3	6	50	75	75	115
037	3.7	5	9	50	75	75	115
055	5.5	7.5	12	50	75	75	115
075	7.5	10	18	100	150	150	225
110	11	15	24	100	150	150	225
150	15	20	32	100	150	150	225
185	18.5	25	38	100	150	150	225
220	22	30	45	100	150	150	225
300	30	40	60	100	150	150	225
370	37	50	73	100	150	150	225
450	45	60	91	150	225	225	325
550	55	75	110	150	225	225	325
750	75	100	150	150	225	225	325
900	90	125	180	150	225	225	325
1100	110	150	220	150	225	225	325
1320	132	175	250	150	225	225	325
1600	160	215	310	150	225	225	325
1850	185	250	370	150	225	225	325
2200	220	300	450	150	225	225	325
2800	280	375	550	150	225	225	325

Table 3.3-6 CH2000 440V Models Output Reactor & Maximum Cable Length

## 4 Single phase application

### 4.1 Introduction to the application of frequency reactor and single-phase power system

According to general industry standards, most commercial and industrial electrical equipment require a three-phase power supply system. In the past, three-phase power supply system was not available in non-industrial or non-commercial areas, because the construction cost is much higher than the single-phase power supply system.

For many years, people have used alternative methods to generate a three-phase power system from a single phase power system. The most common methods include phase changers, static phase exchangers and frequency converters with adjustable frequencies. Since the initial investment cost of the frequency converters have decreased and the reliability of products have increased, many users have adopted the frequency converters as the best solution to switch from the single-phase to the three-phase because their production process requires adjustable control units. The frequency converter with single-phase power input is commonly applied in a submerged pump, centrifugal pump, irrigation system, and a spring system and pump jack.

The frequency converters designed for the single-phase power system cannot meet the customers' needs because the single-phase frequency converters generally have less horsepower. Therefore, it is necessary to adjust the three-phase frequency converter to the single phase power system with larger capacity requirement.

When applying the single-phase power system to the three-phase frequency converters, it is necessary to be aware of the following restrictions. Standard pulse-width modulation (PWM) frequency converters use 6-pulse diode rectifiers. The structure is simple and the cost is low. The 360Hz ripple DC bus used in the 6-pulse rectifier unit can be used together with the three-phase 60HZ, as shown in Figure 4.1-1. However, under the single-phase power input, the ripple of DC bus is 120Hz, and the DC bus circuit of the frequency converter will provide equivalent strength due to higher voltage. In addition, comparing the single-phase input current, harmonics and three-phase input, the distortion of the single-phase input current is 90% THD and the three-phase input is about 40%, as shown in Figure 4.1-2. Therefore, in the use of single-phase input, it is necessary to reduce the rated capacity of the three-phase frequency converter to avoid voltage overshoot of the rectifier and DC components.

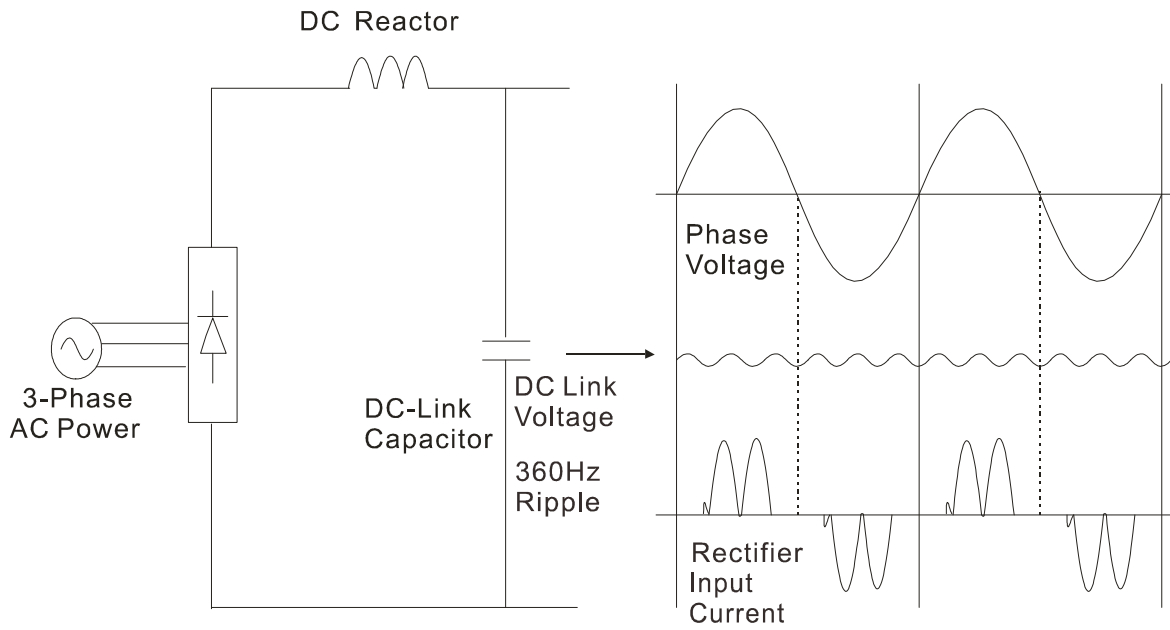

About 40% I-THD

Figure 4.1-1

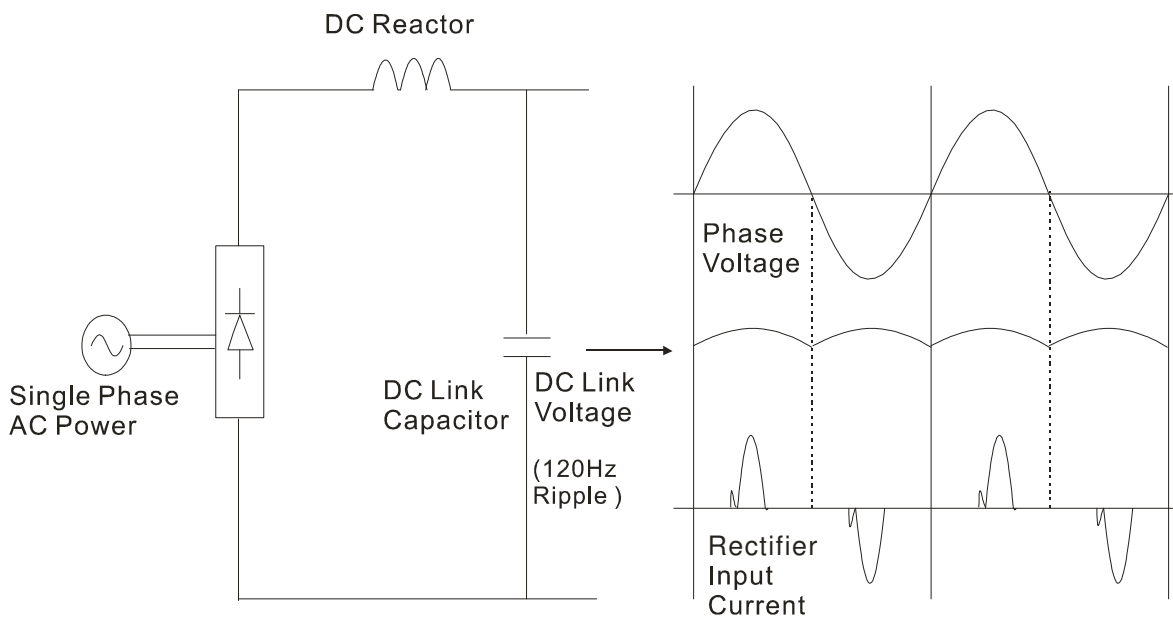

About 90% I-THD

Figure 4.1-2

## 4.2 Key items to consider when using the three-phase frequency converter for single-phase power input.

DELTA VFD-C2000/VFD-CH2000 series frequency converters have been tested and UL certified for the application of single-phase power input. Under the usage requirements specified within this document, proper motor connection and load capacity, the operational safety and service life can be assured.

When using the three-phase frequency converter with the single-phase power input, please make sure power is supplied from the R-S (L1-L2) terminal. Due to the increase in DC bus ripple voltage, it is necessary to reduce rated output current and horsepower. In addition, when the input current passes through the second phase, approximately double the current will be generated at the diode rectifier bridge. This is a factor for consideration for the rate reduction in frequency converters. The reason for the increase in single-phase input power is the conversion of three-phase current to single-phase current ( $\sqrt{3}$ ) and the reduction of overall power factor. Due to the increase in the distortion of the input current ripple, the overall input power factor is lower than the three-phase factor. The overall power factor is 0.7, which is a typical value for the single-phase power input and the installation of a reactor is recommended. The power factor of 0.9 is a typical value for the installation of reactor and three-phase input. In the case of a single-phase input without any reactor, having 100% input current distortion is possible. Therefore, it is necessary to install a reactor.

Under the single-phase input, the output rated current of the C2000/CH2000 series should be adjusted as follows:

1. Without an additional AC reactor, the output rated current for models frame number C and below is reduced to 50%, and the output rated current for models frame number D and higher is reduced to 35%.
2. With a 3% AC reactor installed, the output rated current for models frame number C and below is reduced to 55%, and the output rated current for models frame number D and higher is reduced to 40%.
3. When a 5% AC reactor is installed, the output rated current for models frame number C and below is reduced to 60%, and the output rated current for frame number D and higher is reduced to 45%.

Tables 4.2-1 and 4.2-2 show the appropriate frequency converters to use with C2000/CH2000 in electrical machinery.

Tables 4.2-3 and 4.2-4 show the appropriate frequency converters to use with C2000/CH2000 in electrical machinery, and if a 3% AC reactor is installed in the frequency converter input device.

Tables 4.2-5 and 4.2-6 show the appropriate frequency converters to use with C2000/CH2000 in electrical machinery, and if a 5% AC reactor is installed in the frequency converter input device.

DELTA electric frequency converter VFD-C2000/ VFD-CH2000 having a frame number D or above have built-in reactors. Therefore, these models do not require additional reactors. However, for higher power factor or lower harmonic current, AC reactors can be added. If the use of a super large frequency converter is required for the electrical machinery, please consider its service factor. Selection of the frequency converter should meet all service factors (HP and FLA), and it is necessary to meet or exceed the values listed on the motor nameplate (HP) and motor nameplate's full load amperage (FLA). If the selected frequency converter only meets one of the two requirements, it is likely to result in poor performance, damages the frequency converter and voids warranty.

### **4.3 Input frequency and voltage permissible values**

The rated value of the frequency converter in Tables 4.2-1 to 4.2-6 is based on single-phase input of 60Hz. If it is operating at the output frequency other than 60Hz, the frequency converter should be examined by its manufacturer. The single-phase input power supply must be in 220/440Vac, within -10% to +5% of the maximum voltage range of the motor. There is a permissible range of -10% to +15% between the standard product and the three-phase voltage input. Therefore, when using a frequency converter on a single-phase power supply, a stricter permissive value of input voltage from -10% to +5% is required. Single-phase input DC bus voltage is lower than the equivalent three-phase input. Therefore, the maximum output voltage (motor voltage) will be lower than the single-phase input.

The input voltage cannot be lower than 228Vac for model 230VAC, and 456Vac for model 460VAC to ensure proper voltage generation of 207Vac and 415Vac motors. Therefore, it is necessary to maintain the stability of input voltage if the basic speed of the motor torque is required under a full load. Increase the number of transformers is a good way to obtain rated horsepower.

Tables 4.2-1 to 4.2-2 can help with the selection of frequency converters for motors between 220Vac and 440Vac. For a single phase input current, the relevant values for choosing the corresponding reactors, diameters for the input wire and overload protection circuit breakers are described in Tables 4.2-3 to 4.2-6. The additional reactor sets the standard for limiting the DC bus ripple and improves the input power factors of all models. The overload capacity of the frequency converter will increase due to the DC bus ripple of the single-phase input. Therefore, it is necessary to fully understand the overload requirements of all applications. Before selecting a single-phase application, you must obtain relevant data from the motor's nameplate such as horsepower (HP) and full load amperage (FLA). The selected drive should meet or exceed the HP and FLA requirements listed on the motor's nameplate.

C2000/CP2000/CH2000 230V					
Motor (KW)	Input Phase	Rated Input Current of Motor Drive	Rated Output Current of Motor Drive	Corresponding Motor Drive (KW)	Line Fuse
0.75	R-S (L1-L2)	11.5	5	2.2	JJN-20
1.5	R-S (L1-L2)	18.4	8	3.7	JJN-35
2.2	R-S (L1-L2)	25.3	11	5.5	JJN-50
3.7	R-S (L1-L2)	39.1	17	7.5	JJN-80
5.5	R-S (L1-L2)	57.5	25	11	JJN-110
7.5	R-S (L1-L2)	75.9	33	15	JJN-150
11	R-S (L1-L2)	93.1	49	37	JJN-225
15	R-S (L1-L2)	123.5	65	45	JJN-300
18.5	R-S (L1-L2)	142.5	75	55	JJN-350
22	R-S (L1-L2)	171	90	75	JJN-400
30	R-S (L1-L2)	228	120	90	JJN-450

Table 4.2-1: C2000/CP2000/CH2000 230V Models

C2000/CP2000/CH2000 460V					
Motor (KW)	Input Phase	Rated Input Current of Motor Drive	Rated Output Current of Motor Drive	Corresponding Motor Drive (KW)	Line Fuse
0.75	R-S (L1-L2)	6.9	3	2.2	JJS-15
1.5	R-S (L1-L2)	9.2	4	3.7	JJS-20
2.2	R-S (L1-L2)	13.8	6	5.5	JJS-25
3.7	R-S (L1-L2)	20.7	9	7.5	JJS-40
4	R-S (L1-L2)	24.15	10.5	11	JJS-50
5.5	R-S (L1-L2)	27.6	12	11	JJS-50
7.5	R-S (L1-L2)	41.4	18	18.5	JJS-80
11	R-S (L1-L2)	55.2	24	30	JJS-110
15	R-S (L1-L2)	60.8	32	45	JJS-125
18.5	R-S (L1-L2)	72.2	38	55	JJS-150
22	R-S (L1-L2)	85.5	45	75	JJS-175
30	R-S (L1-L2)	114	60	90	JJS-225
37	R-S (L1-L2)	138.7	73	110	JJS-300
45	R-S (L1-L2)	172.9	91	132	JJS-350
55	R-S (L1-L2)	209	110	160	JJS-400
75	R-S (L1-L2)	285	150	220	JJS-500
90	R-S (L1-L2)	342	180	280	JJS-600
110	R-S (L1-L2)	418	220	315	JJS-800
132	R-S (L1-L2)	494	260	450	KTU-1000

Table 4.2-2: C2000/CP2000/CH2000 460V Models

C2000/CP2000/CH2000 230V models connected to a 3% AC Reactor								
Motor (KW)	Input Phase	Rated Input Current of Motor Drive	Rated Output Current of Motor Drive	Corresponding Motor Drive (KW)	3% Impedance (mH)	Max. continuous Amps of Reactor (Arms)	Delta Part # of Reactor	Line Fuse
0.75	R-S (L1-L2)	9.5	5	2.2	1.002	18	N/A	JJN-20
1.5	R-S (L1-L2)	15.2	8	3.7	0.649	28.8	N/A	JJN-35
2.2	R-S (L1-L2)	20.9	11	5.5	0.441	43.2	N/A	JJN-50
3.7	R-S (L1-L2)	32.3	17	7.5	0.32	55.8	DR033AP320	JJN-80
5.5	R-S (L1-L2)	47.5	25	11	0.216	84.6	DR049AP215	JJN-110
7.5	R-S (L1-L2)	62.7	33	15	0.163	111.6	DR065AP162	JJN-150
11	R-S (L1-L2)	93.1	49	22	0.123	154.8	N/A	JJN-225
15	R-S (L1-L2)	123.5	65	45	0.061	307.8	N/A	JJN-300
18.5	R-S (L1-L2)	142.5	75	55	0.051	367.2	N/A	JJN-350
22	R-S (L1-L2)	171	90	75	0.043	435.6	N/A	JJN-400
30	R-S (L1-L2)	228	120	90	0.032	592.2	N/A	JJN-450

Table 4.2-3: C2000/CP2000/CH2000 230V models connected to a 3% AC Reactor



C2000/CP2000/CH2000 460V models connected to a 3% AC Reactor								
Motor (KW)	Input Phase	Rated Input Current of Motor Drive	Rated Output Current of Motor Drive	Corresponding Motor Drive (KW)	3% Impedance (mH)	Max. continuous Amps of Reactor (Arms)	Delta Part # of Reactor	Line Fuse
0.75	R-S (L1-L2)	5.7	3	2.2	3.522	10.26	N/A	JJS-15
1.5	R-S (L1-L2)	7.6	4	3.7	2.348	14.58	N/A	JJS-20
2.2	R-S (L1-L2)	11.4	6	4	2.013	17.1	N/A	JJS-25
3.7	R-S (L1-L2)	17.1	9	7.5	1.174	30.6	DR018A0117	JJS-40
4	R-S (L1-L2)	19.95	10.5	11	0.881	41.4	DR024AP880	JJS-50
5.5	R-S (L1-L2)	22.8	12	11	0.881	41.4	DR024AP880	JJS-50
7.5	R-S (L1-L2)	34.2	18	15	0.66	54	DR032AP660	JJS-80
11	R-S (L1-L2)	45.6	24	22	0.47	77.4	N/A	JJS-110
15	R-S (L1-L2)	60.8	32	30	0.352	102.6	N/A	JJS-125
18.5	R-S (L1-L2)	72.2	38	45	0.232	154.8	N/A	JJS-150
22	R-S (L1-L2)	85.5	45	55	0.192	189	N/A	JJS-175
30	R-S (L1-L2)	114	60	75	0.141	257.4	N/A	JJS-225
37	R-S (L1-L2)	138.7	73	90	0.117	307.8	N/A	JJS-300
45	R-S (L1-L2)	172.9	91	110	0.096	376.2	N/A	JJS-350
55	R-S (L1-L2)	209	110	160	0.068	531	N/A	JJS-400
75	R-S (L1-L2)	285	150	185	0.057	633.6	N/A	JJS-500
90	R-S (L1-L2)	342	180	220	0.047	786.6	N/A	JJS-600
110	R-S (L1-L2)	418	220	280	0.038	941.4	N/A	JJS-800
132	R-S (L1-L2)	494	260	355	0.031	1168.2	N/A	KTU-1000
160	R-S (L1-L2)	589	310	450	0.024	1468.8	N/A	KTU-1200

Table 4.2-4: C2000/CP2000/CH2000 460V models connected to a 3% AC reactor

C2000/CP2000/CH2000 230V connected to a 5% AC Reactor							
Motor (KW)	Input Phase	Rated Input Current of Motor Drive	Rated Output Current of Motor Drive	Corresponding Motor Drive (KW)	5% Impedance Connected (mH)	Max. continuous Amps of Reactor (Arms)	Line Fuse
0.75	R-S (L1-L2)	9.5	5	1.5	2.297	12.78	JJN-20
1.5	R-S (L1-L2)	15.2	8	3.7	1.081	28.8	JJN-35
2.2	R-S (L1-L2)	20.9	11	5.5	0.735	43.2	JJN-50
3.7	R-S (L1-L2)	32.3	17	7.5	0.534	55.8	JJN-80
5.5	R-S (L1-L2)	47.5	25	11	0.359	84.6	JJN-110
7.5	R-S (L1-L2)	62.7	33	15	0.271	111.6	JJN-150
11	R-S (L1-L2)	93.1	49	22	0.204	154.8	JJN-225
15	R-S (L1-L2)	123.5	65	37	0.126	250.2	JJN-300
18.5	R-S (L1-L2)	142.5	75	45	0.102	307.8	JJN-350
22	R-S (L1-L2)	171	90	55	0.085	367.2	JJN-400
30	R-S (L1-L2)	228	120	75	0.072	435.6	JJN-450
37	R-S (L1-L2)	277.4	146	90	0.053	592.2	JJN-500

Table 4.2-5: C2000/CP2000/CH2000 230V models connected to a 5% AC Reactor

C2000/CP2000/CH2000 460V models connected to a5% AC Reactors							
Motor (KW)	Input Phase	Rated Input Current of Motor Drive	Rated Output Current of Motor Drive	Corresponding Motor Drive (KW)	5% Impedance Connected (mH)	Max. continuous Amps of Reactor (Arms)	Line Fuse
0.75	R-S (L1-L2)	5.7	3	2.2	5.871	10.26	JJS-15
1.5	R-S (L1-L2)	7.6	4	3.7	3.914	14.58	JJS-20
2.2	R-S (L1-L2)	11.4	6	4	3.355	17.1	JJS-25
3.7	R-S (L1-L2)	17.1	9	7.5	1.957	30.6	JJS-40
4	R-S (L1-L2)	19.95	10.5	7.5	1.957	30.6	JJS-50
5.5	R-S (L1-L2)	22.8	12	11	1.468	41.4	JJS-50
7.5	R-S (L1-L2)	34.2	18	15	1.101	54	JJS-80
11	R-S (L1-L2)	45.6	24	18.5	0.927	64.8	JJS-110
15	R-S (L1-L2)	60.8	32	30	0.587	102.6	JJS-125
18.5	R-S (L1-L2)	72.2	38	45	0.387	154.8	JJS-150
22	R-S (L1-L2)	85.5	45	55	0.32	189	JJS-175
30	R-S (L1-L2)	114	60	75	0.235	257.4	JJS-225
37	R-S (L1-L2)	138.7	73	90	0.196	307.8	JJS-300
45	R-S (L1-L2)	172.9	91	110	0.16	376.2	JJS-350
55	R-S (L1-L2)	209	110	132	0.141	444.6	JJS-400
75	R-S (L1-L2)	285	150	185	0.095	633.6	JJS-500
90	R-S (L1-L2)	342	180	220	0.078	786.6	JJS-600
110	R-S (L1-L2)	418	220	280	0.064	941.4	JJS-800
132	R-S (L1-L2)	494	260	280	0.064	941.4	KTU-1000
160	R-S (L1-L2)	589	310	355	0.052	1168.2	KTU-1200
185	R-S (L1-L2)	703	370	450	0.041	1468.8	KTU-1400

Table 4.2-6: C2000/CP2000/CH2000 460V models connected to a 5% AC Reactors

## 5. Precautions for heat dissipation and environment conditions:

### 5.1 Troubleshooting

The frequency converter is equipped with high powered electronic components. If they are not installed properly, maintained regularly or used correctly, the failsafe mechanism may be triggered to prevent damages to the frequency converter. When an abnormal signal is detected, the following steps can be used for troubleshooting. If the problem persists, please contact DELTA directly.

Item	Problem	Solution	Reference page
1.1	How to conduct an initial check if the frequency converter triggers OH1 signal?	1.1.1 Check if the clearance area around frequency converter meets the minimum distances specified in the installation manual, and the installation location is not affected by nearby equipment. If the requirements are now met, please take corrective action.	<u>P.85</u>
		1.1.2 Check if there are other heat sources near the air intake vents on the frequency converter, which causes the temperature of the input air to be too high and exceeds specification. If so, please try to remove it.	Please refer to the product specification documents
		1.1.3 Check if there is a layer of dust covering the radiator of the frequency converter. Please clean off any dust in the area, if any.	<u>P.96</u>
		1.1.4 If the radiator is often covered by a layer of dust due to environment pollution, please consider adding a filter mesh or a booster fan.	<u>P.92</u>
		1.1.5 Check if heat dissipation is affected by dust on the fan. Please clean off any dust in the area, if any.	
1.2	How to conduct initial checks if the frequency converter triggers the OH2 signal?	1.2.1 Check if there are external heat sources near the side air vent of the frequency converter. If it does not meet the requirements stated in the manual, please take corrective action.	<u>P.85</u>
		1.2.2 Check if there are external heat sources near the side ventilation opening of the frequency converter. If so, please remove it or install a separator.	<u>P.89</u>

Contact DELTA directly if the steps listed above fail to solve the problem.

## 5.2 Examples of frequency converters affected by the installation environment

The installation environment has a direct impact on the functionality and service life of the frequency converter. The followings are some examples that demonstrate how improper installation may the service life and reliability of the frequency converter.

Example 1:

- If the frequency converter has a fan on the side, and the design of the cabinet does not equip with any vertical separator to block the interaction of the ventilation openings of the frequency converters, it will result in hot air entering the frequency converters and cause overheating. For the design of the separator, please refer to Section 5.3.1.3.
- If the minimum side clearance is not maintained for the frequency converter, it might cause insufficient air flow of the frequency converter, causing overheating. For the clearance distance required by the frequency converter, please refer to Section 5.3.1.2.



**Improper Installation**

Example 2:

- If the minimum clearance of 50mm cannot be maintained at the left and right sides of the FRAME F frequency converter, it may easily cause overheating because of insufficient ventilation. For the minimum clearances required by the frequency converter, please refer to Section 5.3.1.2.

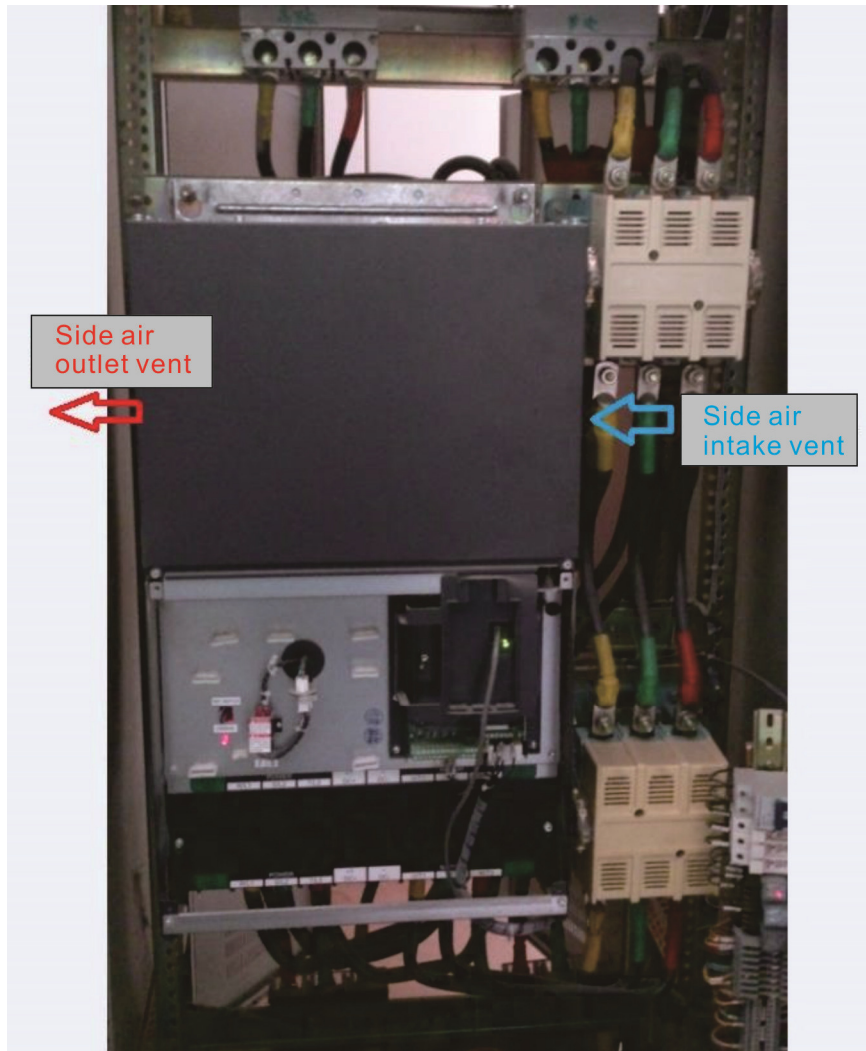

**Improper Installation**

Example 3:

- A minimum clearance of 200mm is not kept at the front of the frequency converter as specified in the manual, so the amount of cool air entering the frequency converter is not enough for heat dissipation. For the minimum clearances required by the frequency converter, please refer to Section 5.3.1.2.

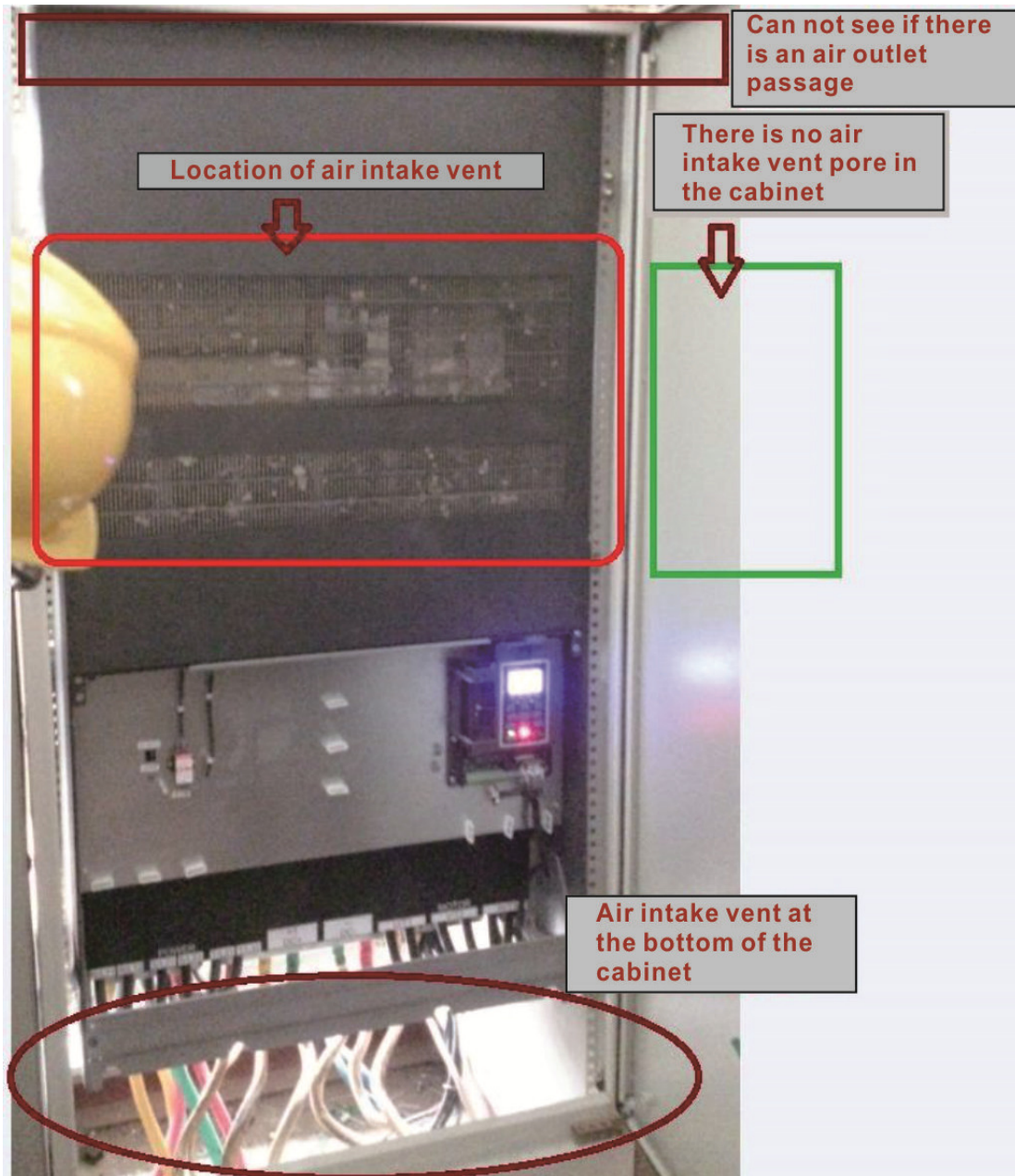

**Improper Installation**

Example 4:

- In this case, even though a booster fan is installed at the top of the cabinet, it did not consider the area requirement of the air inlet and outlet so the amount of air is insufficient. Because there is not enough ventilation, the temperature at the top of the cabinet is high. After years of operation, the fan may be damaged by high temperatures. For the design of cabinet's ventilation area or the selection of a booster fans due to filter mesh installation, please refer to Section 5.3.
- Because it is closer to the ground, the opening for wiring at the bottom of the cabinet may bring dust inside the frequency converter, resulting in obstruction of the radiator and flow path and causing the frequency converter to overheat due to insufficient heat dissipation. It is recommended to install a filter mesh at the opening. Please refer to Section 5.3.2.

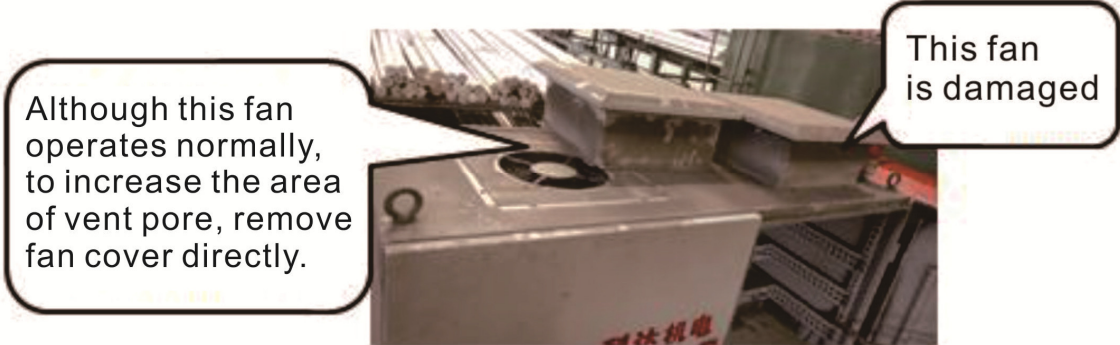
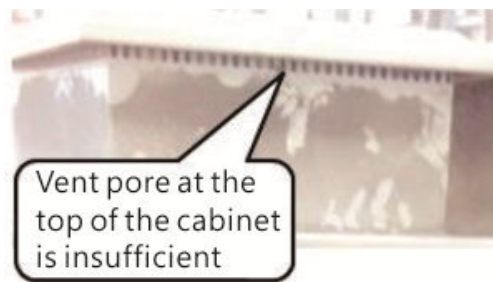





### **Improper Installation**

Therefore, when designing or setting up the cabinet with a frequency converter, the following items should be verified. In addition, providing proper recommendations and signing a contract based on the type of frequency converters used and clients' requirements in order to reduce future complaints from the customer.

## 5.3 Cabinet cooling design

### 5.3.1 Installing the drive in a cabinet with basic protection.

#### 5.3.1.1 Ventilation requirements and the area of the vent opening

Most of the C series drives have built-in cooling fans (only a few Frame A drives have natural convection cooling design), therefore the drives have a certain capacity for wind resistance so that they can be used in a cabinet with basic protection, no additional booster fan is needed. When the drive is configured in the cabinet, it is strongly recommended that the design of the cabinet meet the minimum requirements for effective areas of air inlet and outlet vents to ensure sufficient cooling.

The effective area is calculated by taking the actual area of the opening multiplied by the vent pore ratio. The formula is as follows:

$$\text{Effective Area} = \text{Actual Area of Opening} \times \text{Vent Pore Ratio}$$

Table 5.3.1.1-1, Table 5.3.1.1-2 and Table 5.3.1.1-3 show the minimum air demands and minimum effective vent areas for a single C2000, CH2000, CP2000 drive, respectively. The table lists the minimum wind demands and minimum effective vent area for a single drive. If there are several drives in the cabinet, please sum up the values for minimum wind demand and minimum vent area in order to meet the cooling requirement. If the cabinet cannot provide enough effective vent area, please try the following:

Select an appropriate booster fan to assist with heat dissipation. How to select

- A. First, find out the minimum effective vent area of the cabinet.
- B. Based on the area, search for fans with the closest corresponding cross-sectional area.
- C. When the required minimum effective vent area is much greater than the cross-sectional area of the fan, several fans can be used in parallel. However, please make sure the sum of the maximum flow of all fans is greater than the required flow of the frequency converter.
- D. Combined with the separator suggested in Section 5.3.1.3 to achieve the optimum ventilation design.

	Frame Size of Motor Drive	Power	Air Flow Rate for Cooling		Minimum Effective Air-admitting Surface on the Distribution Case	
					Air Intake Vent (Bottom)	Air Outlet Vent (Top)
Unit	-	kW	m <sup>3</sup> /hr	cfm	m <sup>2</sup>	m <sup>2</sup>
230V model	A	0.75~3.7	24	14	0.003	0.003
	B	5.5~11	136	80	0.019	0.019
	C	15~22	302	178	0.042	0.042
	D	30~37	355	209	0.049	0.049
	E	45~75	542	319	0.074	0.074
	F	90	571	336	0.078	0.078
460V model	A	0.75~5.5	24	14	0.003	0.003
	B	7.5~15	136	80	0.019	0.019
	C	18.5~30	250	147	0.034	0.034
	D	37~75	367	216	0.050	0.050
	E	90~110	561	330	0.077	0.077
	F	132~160	681	401	0.094	0.094
	G	185~220	771	454	0.106	0.106
	H	280~450	1307	769	0.179	0.179

Table 5.3.1.1-1: Minimum Effective Air-admitting Surface on the Distribution Case of VFD-C2000

	Frame Size of Motor Drive	Power	Air Flow Rate for Cooling		Minimum Effective Air-admitting Surface on the Distribution Case	
					Air Intake Vent (Bottom)	Air Outlet Vent (Top)
Unit	-	kW	m <sup>3</sup> /hr	cfm	m <sup>2</sup>	m <sup>2</sup>
230V modles	A	0.75~3.7	24	14	0.003	0.003
	B	5.5~11	136	80	0.019	0.019
	C	15~18.5	302	178	0.042	0.042
	D	22~37	355	209	0.049	0.049
	E	45~55	542	319	0.074	0.074
	F	75	571	336	0.078	0.078
460V models	A	0.75~5.5	24	14	0.003	0.003
	B	7.5~15	124	72	0.019	0.019
	C	18.5~30	204	120	0.034	0.034

	Frame Size of Motor Drive	Power	Air Flow Rate for Cooling		Minimum Effective Air-admitting Surface on the Distribution Case	
					Air Intake Vent (Bottom)	Air Outlet Vent (Top)
	D	37~75	367	216	0.050	0.050
	E	90~110	561	330	0.077	0.077
	F	132	571	336	0.094	0.094
	G	160~220	771	454	0.106	0.106
	H	280	1307	769	0.179	0.179

Table 5.3.1.1-2 Minimum Effective Air-admitting Surface on the Distribution Case of VFD-CH2000

	Frame Size of Motor Drive	Power	Air Flow Rate for Cooling		Minimum Effective Air-admitting Surface on the Distribution Case	
					Air Intake Vent (Bottom)	Air Outlet Vent (Top)
Unit	-	kW	m3/hr	cfm	m2	m2
230V models	A	0.75~5.5	24	14	0.003	0.003
	B	7.5~15	136	80	0.019	0.019
	C	18.5~30	302	178	0.042	0.042
	D	37~45	355	209	0.049	0.049
	E	55~90	542	319	0.074	0.074
460V models	A	0.75~7.5	24	14	0.003	0.003
	B	11~18.5	136	80	0.019	0.019
	C	22~37	250	147	0.034	0.034
	D	45~90	367	216	0.050	0.050
	E	110~132	561	330	0.077	0.077
	F	160~185	681	401	0.094	0.094
	G	220~280	771	454	0.106	0.106
	H	315~400	1307	769	0.179	0.179

Table 5.3.1.1-3 Minimum Effective Air-admitting Surface on the Distribution Case of VFD-CP2000

Note: A reasonable reduction in the temperature of the application environment can make up for having not enough vent area.

### 5.3.1.2 Clearance required by a drive

When the drives are installed in the cabinet, the location of each drive should take into consideration if the minimum clearance for air flow is reserved, and to prevent improper use which may trigger the overheating protection of the drives and result in shutdown of the drives.

If the actual installation does not meet the minimum clearance, please install a booster fan to satisfy the minimum requirements of air flow and surrounding temperature. The desired measurement point for the temperature is 50mm away from each ventilation opening of the frequency drive.

The following are some of the cabinet recommendations based on most frequent scenarios.

← (blue arrows) incoming direction of air

← (red arrow) outgoing direction of air

- Stand-alone installation of a single drive:

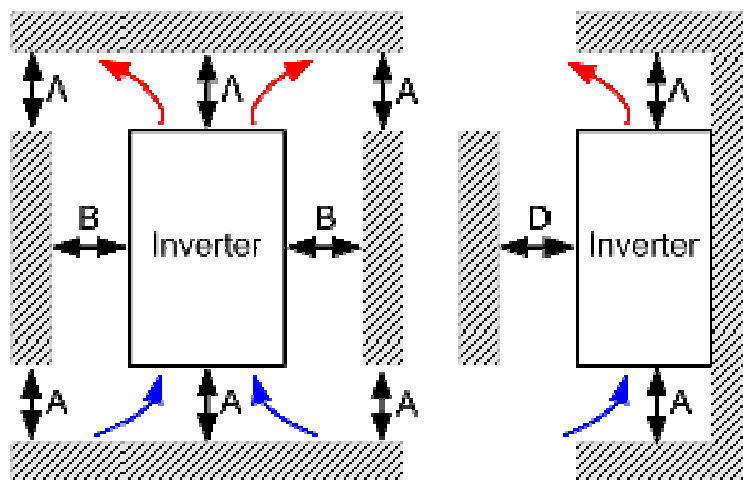

Figure 5.3.1.2-1 Single drive installation  
(Frame A-H)

- Horizontal installation of multiple drives:

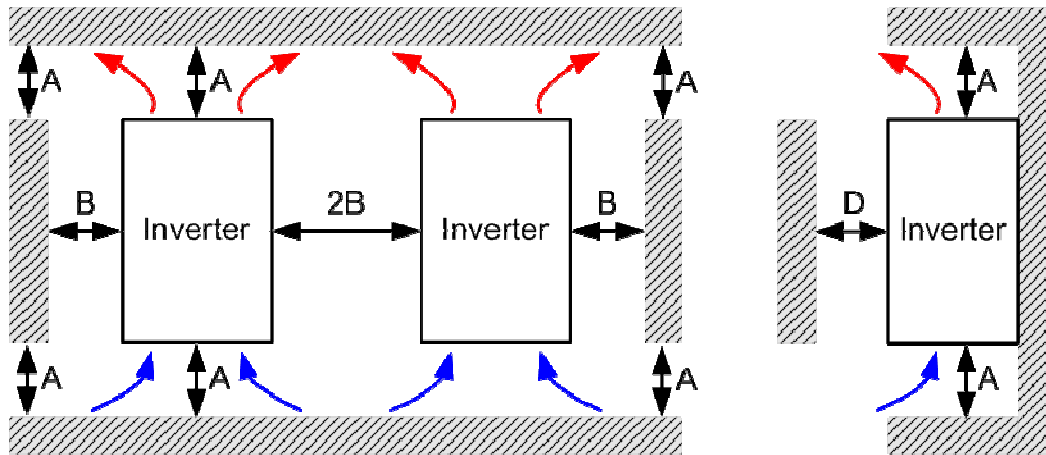

Figure 5.3.1.2-2 Multiple drives, single side-by-side horizontal installation (Frame A~C, G, H)

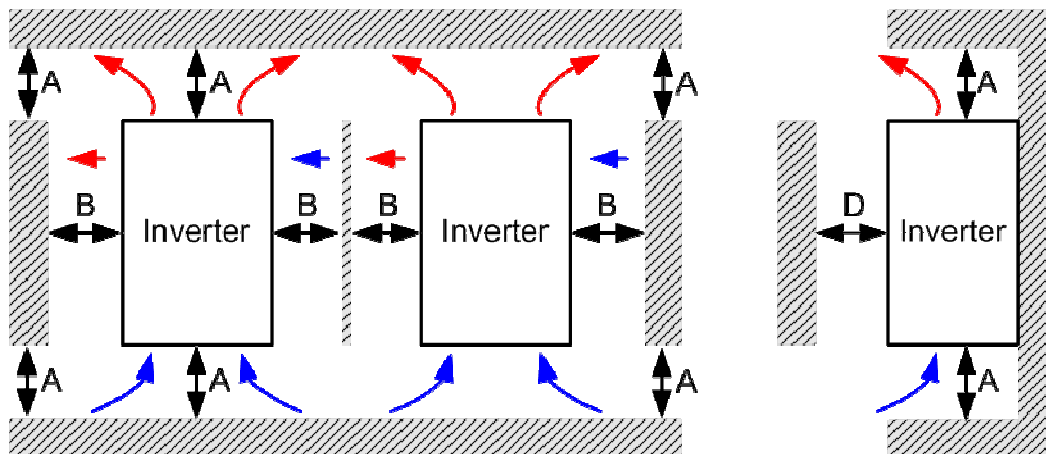

Figure 5.3.1.2-3 Multiple drives, side-by-side installation (Frame D0, D, E, F).  
Install a metal separation between the drives.

- Vertical installation of multiple drives in parallel:

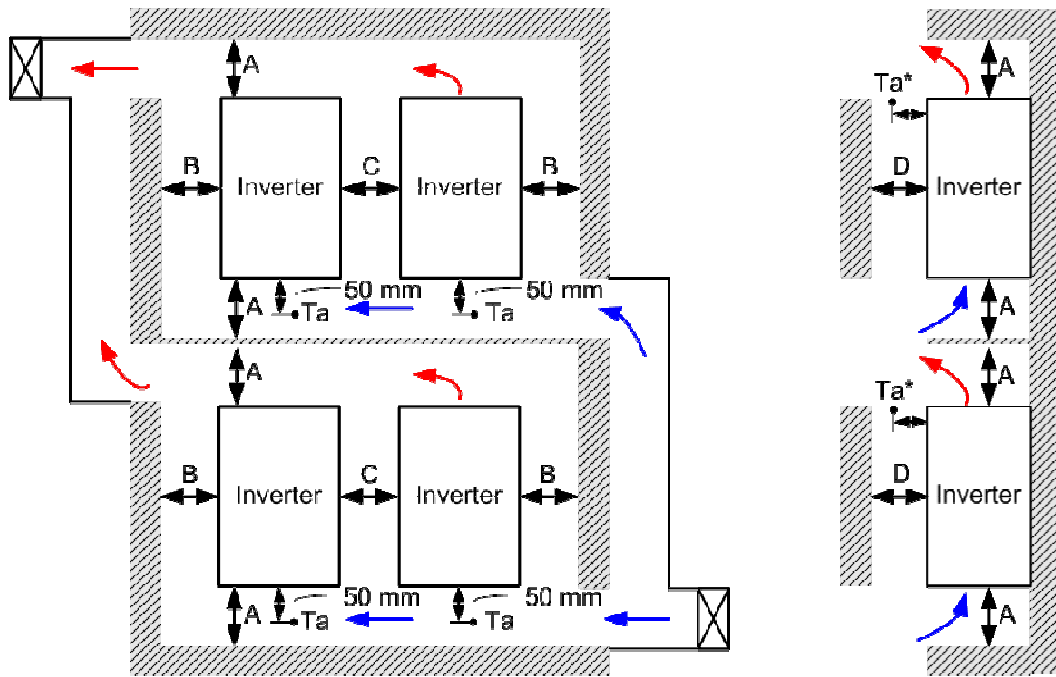

Figure 5.3.1.2-4 Multiple drives side –by-side vertical installation (Frame A, B, C, G, H)  
 Ta: Fame A, B, C, G. Ta\*: Frame H

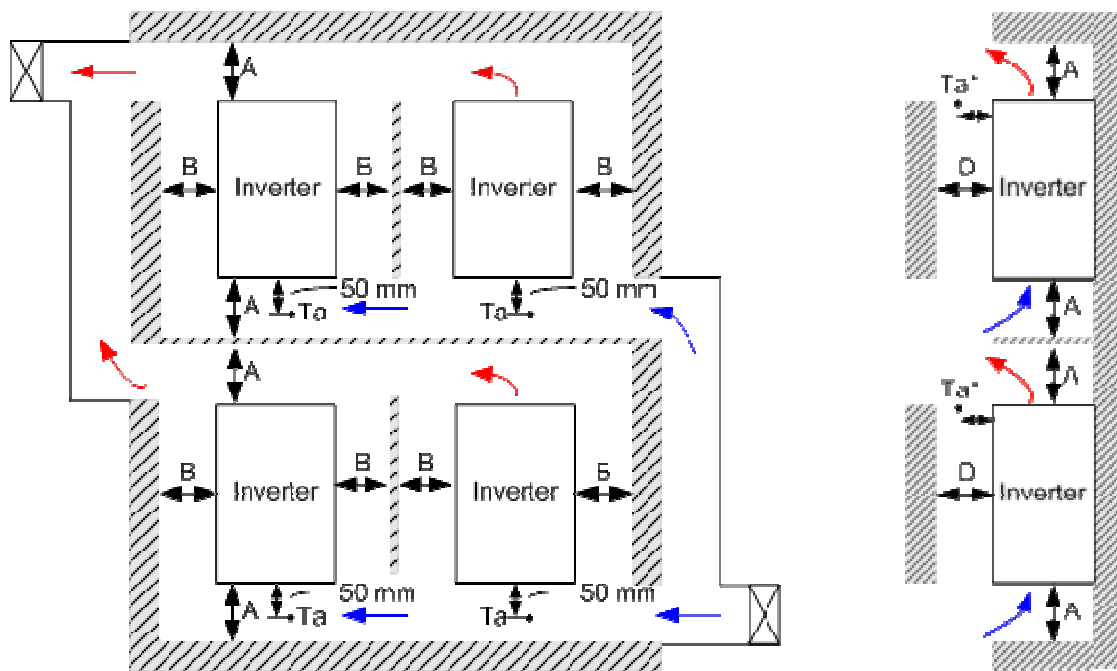

Figure 5.3.1.2-5 Multiple drives side –by-side vertical installation  
 (Frame D0, D, E, F)

- Minimum clearance:

Frame	A (mm)	B (mm)	C (mm)	D (mm)
A~C	60	30	10	0
D0~F	100	50	-	0
G	200	100	-	0
H	350	0	0	200 (100, Ta=40°C)

Table 5.3.1.2 Minimum mounting clearance

### 5.3.1.3 Separator requirements

In order to prevent recirculation of air inside the cabinet, installation of separators within the cabinet is highly recommended. Air recirculation may cause drive to overheat and trigger the overheating failsafe, resulting in shutdown of the drives.

The drive's internal fan generates an upward air flow. Therefore, a low pressure zone is generated near the bottom of the cabinet. A high pressure zone is created at the top. The low pressure zone at the bottom causes cool air to enter through the vent at the bottom of the cabinet. The cool air flows to the inside of the drive, after being heated, it raises to the high pressure zone at the top of the cabinet. The hot air at the high pressure zone is expelled through the vent at the top to complete the air exchange.

However, to prevent air recirculation and complete the aforementioned air exchange, a separator is required. If there is no separator in the cabinet, the high pressure zone at the top and low pressure zone at the bottom will cause hot air from the top to re-circulate to the bottom, which traps in the hot air instead of effectively expelling it out of the cabinet, resulting in overheating of the drive's internal parts.

Metal or plastic sheets can be used as separators. When designing the separator, please make sure the separator is in close contact with the surrounding cabinet and properly sealed to prevent recirculation of hot air.

**Design of the horizontal separator:** The purpose of the horizontal separator is to prevent air re-circulation from the high pressure zone at the top to the low pressure zone at the bottom. The installation of the separator at a proper position can effectively prevent air recirculation. In principle, the location of the horizontal separator is near the top of the drive.

**Design of the vertical separator:** The vertical separator is needed for models with a side panel fan (Frames D0, D, E, F), and multiple drive configurations as shown in Figures 5.3.1.2-3 and 5.3.1.2-5. It is recommended to design vertical separators to avoid existing hot air being circulated into vents of the surrounding drives, and the minimum clearances shown in 5.3.1.2 should be kept. For models without side panel fans, the vertical separator is not required. It is sufficient to simply maintain the minimum clearances on the left and right sides.



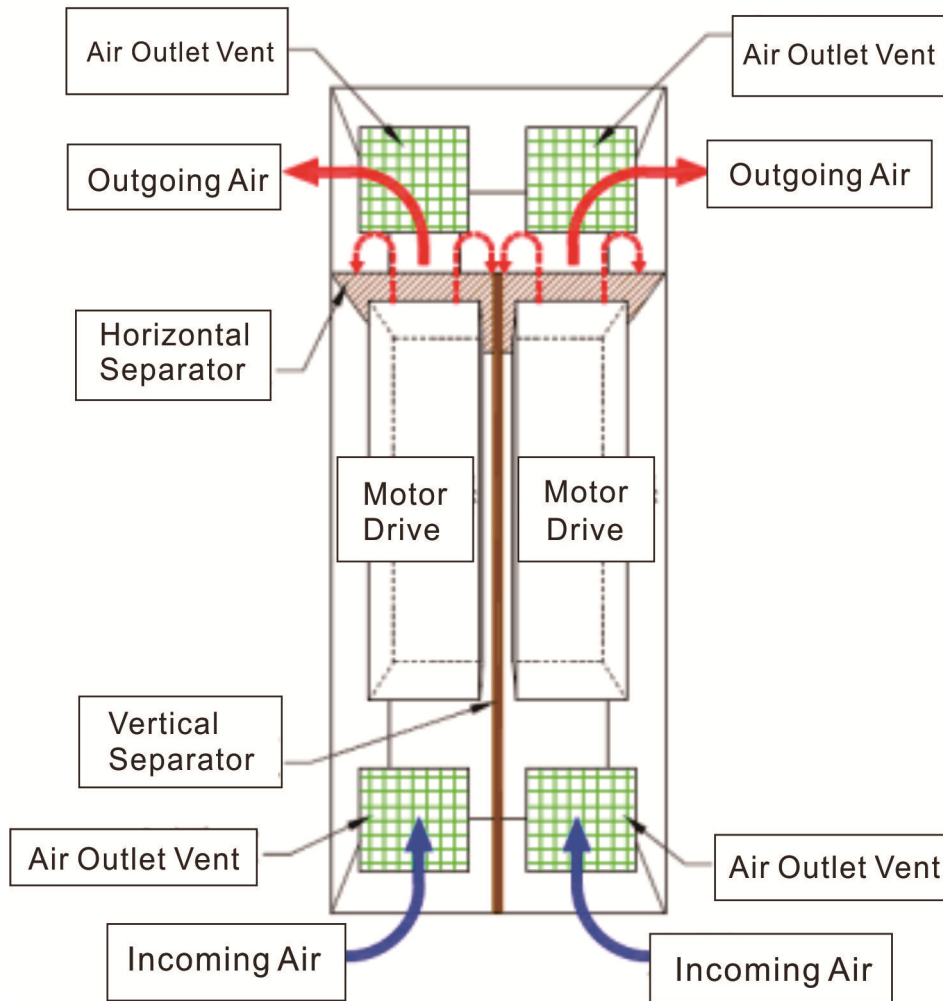

Figure 5.3.1.3 The path of air flow inside the distribution case and installation of separators

#### 5.3.1.4 Design of multiple drives in the cabinet

When multiple drives exist in the same cabinet, please pay special attention to the following:

- i. Are there sufficient air intake and air outlet areas within the cabinet?
- ii. Is there enough clearance between each drive?
- iii. Verify the setup of horizontal and vertical separators.

#### i. **Please double check the air intake and outlet areas inside the cabinet.**

When multiple drives are configured in the same cabinet, please make sure that the minimum effective air inlet and outlet areas are kept. How to estimate the minimum effective ventilation area for multiple drives? Find out the corresponding ventilation area of each model from Table 5.3.1.1, and the total for each drive is the minimum required air inlet and outlet area for the cabinet.

**For example:** A cabinet is configured with two C2000 460V 75kW drives and one C2000 460V 160kW drive. By checking Table 5.3.1.1-1, the minimum ventilation area for one 460V 75kW drive is 0.05m<sup>2</sup>; the minimum ventilation area for one 460V 160kW drive is 0.094m<sup>2</sup>. After calculation, the total required ventilation area is 0.194 m<sup>2</sup>, i.e., the minimum effective air inlet area is 0.194 m<sup>2</sup>. The minimum effective area of air inlet is 0.194 m<sup>2</sup>.

When multiple drives exist in one cabinet, but the required ventilation conditions cannot be met (i.e., the maximum possible ventilation area on the cabinet is less than the required ventilation area), please refer to Section 5.3.1.1 for recommendations on how to achieve optimum ventilation.

**ii. The minimum clearance of each drive**

When multiple drives exist in one cabinet, the minimum clearance of each drive is shown in Section 5.3.1.2.

**iii. Design of horizontal and vertical separators**

When multiple drives are configured in a cabinet, the design of the horizontal separator is described in Section 5.3.1.3. In addition, for drives with side panel fans, in order to prevent the hot air expelled by a drive's side panel vent from entering the side panel vent of another drive, vertical separators are required. Please refer to Section 5.3.1.3.

## 5.3.2 Designing the drive in a dust-proof cabinet

### 5.3.2.1 Recommendations for a protective filter mesh

When the drive cabinet is located in a dusty environment, and the requirement for dust protection level is IP5X, dust filter meshes can be installed at the air inlets and outlets of the cabinet. The filter mesh should have low pressure drop after air flow, easy to clean and certain degree of flame resistance. In order to meet the above requirements, it is recommended to use filter meshes manufactured by UAF (<http://www.uaf.com/>). The 25 PPI (pores per inch) and 0.25 in. thickness (6.35mm) from the Quadrafoam series can achieve the IP5X protection level and meet the application requirements of most industrial environment. In addition, the size of the filter mesh can be customized.

For specifications on inlet and outlet filter mesh areas of the cabinet, please refer to the minimum required effective area in Table 5.3.1.1. If there are multiple drives, please refer to Section 5.3.1.4 for instructions on to properly design and plan.

### 5.3.2.2 Booster fans recommendation

With the UAF Quadraform (25 PPI, 0.25 in. thickness) filter meshes recommended in Section 5.3.2.1 installed, the protection level as well as the system's impedance is increased, leading to a decrease in air flow which might cause overheating, and the failsafe measures might shut down the system.

In order to prevent system failure, booster fans must be installed at the top of the cabinet during filter mesh installation in order to meet the air flow demand.

For convenience and avoid having to search for a DC power source, fans with AC input are recommended. The following are some examples of AC fans. Customers can choose the recommended model or fans with equal efficiency.

When filter meshes are used for the cabinet with multiple drives, the easiest way to select a fan is to look up the recommended minimum air flow of each model in Table 5.3.1.1. After air flow values are summed up, look for the model closest to the air flow demand, then select the fan.

**For example:** A cabinet is configured with two C2000 460V 75kW drives and one C2000 460V 160kW drive. After checking with Table 5.3.1.1-1, the minimum air flow required for a 460V 75kW drive is 367m<sup>3</sup>/hr; the minimum flow demand of a 460V 160kW drive is 681m<sup>3</sup>/hr. The total air flow demand is 1,415m<sup>3</sup>/hr, which is close to the required air flow of two 460V 220kW drives (1542m<sup>3</sup>/hr), thus it is suitable to select two Sunon/A1259-HBL.

Unit	Frame Size of Motor Drive	Power	Required Air Flow Rate for Cooling		Filter Mess	Minimum Effective Air-admitting Surface on the Distribution Case to place a UAF filter mess		Suggested corresponding booster fan brand/ models
						Air Intake Vent (Bottom)	Air Outlet Vent (Top)	
						m2	m2	
230V series	A	0.75~3.7	24	14	UAF Quadraform (25PPI, 0.25in thickness)	0.003	0.003	Sunon/A1123-HSL
	B	5.5~11	136	80		0.019	0.019	
	C	15~22	302	178		0.042	0.042	Sunon/A1179-HBL
	D	30~37	355	209		0.049	0.049	
	E	45~75	542	319		0.074	0.074	Sunon/A1259-HBL
	F	90	571	336		0.078	0.078	
460V series	A	0.75~5.5	24	14		0.003	0.003	Sunon/A1123-HSL
	B	7.5~15	136	80		0.019	0.019	
	C	18.5~30	250	147		0.034	0.034	Sunon/A1179-HBL
	D	37~75	367	216		0.05	0.05	
	E	90~110	561	330		0.077	0.077	Sunon/A1259-HBL
	F	132~160	681	401		0.094	0.094	
	G	185~220	771	454	0.106	0.106		
	H	280~450	1307	769	0.179	0.179	Sunon/A1259-XBL	

Table 5.3.2.2-1 Booster fans recommendation

Filter Mess	Minimum Effective Air-admitting Surface on the Distribution Case to place a UAF filter mess		Suggested corresponding booster fan brand/ models	Available Air Flow Rate for Cooling	
	Air Intake Vent (Bottom)	Air Outlet Vent (Top)		m <sup>3</sup> /hr	cfm
	m <sup>2</sup>	m <sup>2</sup>			
UAF Quadraform (10PPI, 0.25in thickness)	0.003	0.003	Sunon/A1123-HSL	24	14
	0.019	0.019		136	80
	0.042	0.042	Sunon/A1179-HBL	302	178
	0.049	0.049		355	209
	0.074	0.074	Sunon/A1259-HBL	542	319
	0.078	0.078		571	336
	0.003	0.003	Sunon/A1123-HSL	24	14
	0.019	0.019		136	80
	0.034	0.034	Sunon/A1179-HBL	250	147
	0.05	0.05		367	216
	0.077	0.077	Sunon/A1259-HBL	561	330
	0.094	0.094		681	401
	0.106	0.106		771	454
	0.179	0.179	Sunon/A1259-XBL	1307	769

Table 5.3.2.2-2 Available Air Flow Rate for Cooling by using UAF Filter Mess & Booster Fan

Note:

- If the uses of 2000cfm level fans are required, it is recommended to use the AC fans manufactured by DELTA (Delta/TCB35A2H18) with a maximum output 2432cfm, 3.094inH<sub>2</sub>O.
- Please refer to the Appendix for the specifications of Sunon AC fan.
- If you are unable to purchase the Sunon AC fan, other alternatives are: NMB, Sanyo Denki, Nidec, Sunta Motor, Profan, etc. You can supply the manufacturers with the specifications of the Sunon AC model, and let the manufactures recommend an appropriate model.

### 5.3.3 How to easily clean the dust off the radiator:

After the frequency converter has operated for some time, dust will enter the frequency converter with the flow of air. If dust has accumulated on the radiator, as shown in Figure 5.3.3.1, it may block the air passage and cause overheating.

In order to prevent the blockage of the air passage, whenever dust has accumulated on the radiator, you can use an air gun or a small brush to clean the dust off, as shown in Figure 5.3.3-2.



Figure 5.3.3-1

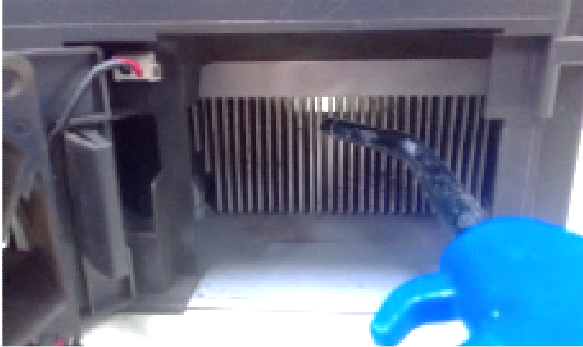

Figure 5.3.3-2

## 5.4 Installation notices and important items:

### 5.4.1 Cabinet dimensions and necessary protective measures:

- A. Verify the conditions at installation site — confirm if the frequency converter meets the client’s environmental conditions (the client’s industry, IP protection requirement). If it does not, please select another frequency converter that meets the client’s environmental conditions. Or confirm if a protective filter mess can be installed at the exterior of the cabinet to protect against dust, moisture and foreign objects. (Please be aware that additional protective measures may result in insufficient air flow, other steps may be necessary to compensate. Please refer to 5.3.2 for more details.)

Protection ratings of commonly used casing material:

**GB 4208—2008/IEC 60529:2001**

composition	Numbers or letters	The meaning for protection equipment	The meaning for personnel protection
Code letter	IP	—	—
The first characteristic numeral	0 1 2 3 4 5 6	Prevent solid objects enter Unprotected ≥ Diameter 50 mm ≥ Diameter 12.5 mm ≥ Diameter 2.5 mm ≥ Diameter 1.0 mm Dust-proof Dust dense	Prevent from approaching hazardous parts ◦ Unprotected ◦ Arms ◦ Fingers ◦ Tool ◦ Metal wires ◦ Metal wires ◦ Metal wires
The second characteristic numeral	0 1 2 3 4 5 6 7 8	Prevent the harmful effects caused by water ◦ Unprotected ◦ Vertical dripping ◦ 15 degrees drip ◦ Drenching ◦ Splash ◦ Spray ◦ Heavy spray ◦ Short-term soaking ◦ Continuous soaking	—
Additional letters (optional)	A B C D	—	Prevent from approaching hazardous parts ◦ Arms ◦ Fingers ◦ Tool ◦ Metal wires
Additional letters (optional)	H M S W	Specialized additional info ◦ High voltage equipment ◦ When do waterproof test, sample run ◦ When do waterproof test, sample standstill ◦ Climatic conditions	—

- B. Confirm the dimensions and limitations at the actual installation site in order to design the proper size and type of cabinet. (wall mounted or on the ground installation)
- C. Confirmation of circuit diagram - confirm the sizes and installation procedures for all electrical components that will be placed in the cabinet, so that a proper order can be establish for installing the internal components.
- D. All preliminary arrangements of the components inside the cabinet — plan for appropriate flow path, reasonable wiring space and reasonable maintenance space (e.g. reserve space for cleaning the components); obtain the dimensions of the cabinet.
- E. Did the customer specify a color for the cabinet?



## 5.4.2 Selecting the frequency converter:

**Based on the selected frequency converter, the following installation information must be verified and forwarded to the cabinet supplier to ensure proper design of the cabinet.**

### 5.4.2.1 Weight

Calculate the weight of the entire cabinet; Based on customer's requirements, design the cabinet structure, location of placement and the installing method; for example: Wall mounted or on the ground installation.

### 5.4.2.2 The size of the frequency converter's mounting holes, recommended screws and tightness; for drilling on the cabinet.

### 5.4.2.3 Locations of air inlet and outlet on the frequency converter

Follow the installation recommendations (such as a wind deflector or separator) and limitations (if side by side installation is allowed) to ensure the proper flow path. For details on the precautions and restrictions, please refer to the clearance requirement Section 5.3.1.2.

### 5.4.2.4 The required air flow and size of the vent opening in the cabinet

When setting up frequency converters inside the cabinet, please pay attention to the air flow demand for heat dissipation. For detailed information, please refer to Section 5.3.1.1, Ventilation requirements and the area of the vent opening.

## 5.4.3 Cabinet design:

**Please check that all relevant information for the frequency converter and circuit diagrams, as well as the design of the cabinet are in accordance with the following: (Check before construction)**

- A. Verify the distance required for heat dissipation, and check if the design and configuration of the cabinet meet the requirements listed in this manual.
- B. Are the air inlet and outlet of the frequency converter unobstructed? Do the wire ducts affect the air flow of the frequency converter? The air flow of cool and hot air are separated in accordance with the requirement. For detailed information on separators, please refer to 5.3.1.3 Separator requirements.
- C. There are two different ways of installing the frequency converter inside the cabinet: the standard mode and the two-stage fixation mode. You can choose the optimum design based on the air flow requirements or the customer's needs.

For example, C2000 Frames A to F were provided with the two-stage fixation method.

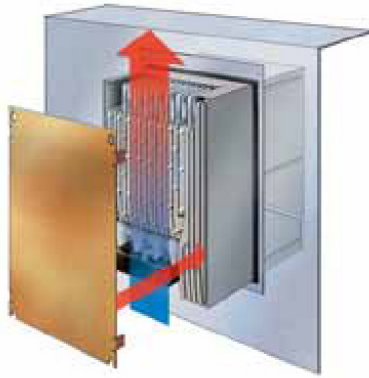

Frame F  
 F2: VFD900C23E; VFD1320C43E; VFD1600C43E

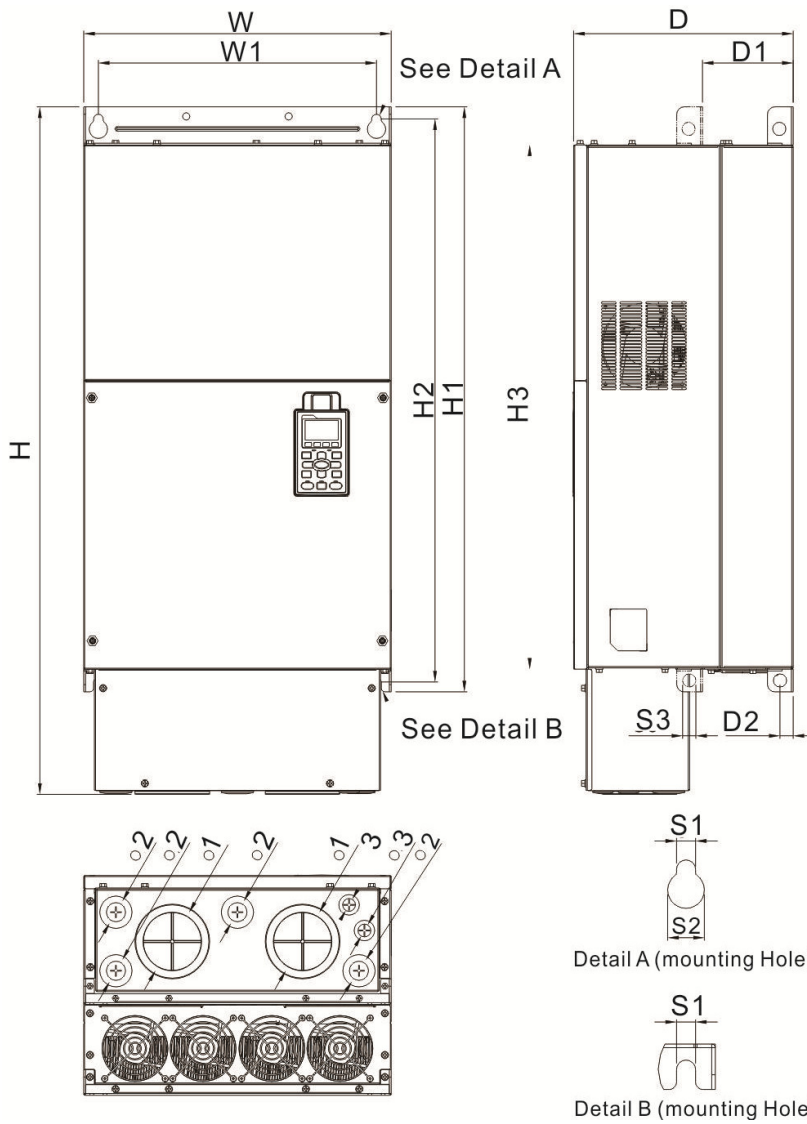

Unit : mm [inch]

Frame	W	H	D	W1	H1	H2	H3	D1*	D2	S1	S2	S3
F2	420.0 [16.54]	940.0 [37.00]	300.0 [11.81]	380.0 [14.96]	800.0 [31.50]	770.0 [30.32]	717.0 [28.23]	124.0 [4.88]	18.0 [0.71]	13.0 [0.51]	25.0 [0.98]	18.0 [0.71]
Frame	Φ1	Φ2	Φ3									
F2	92.0 [3.62]	35.0 [1.38]	22.0 [0.87]									

D1\* : two-stage fixation surface.

- D. Is there sufficient air flow inside the cabinet based on the locations and sizes of the air vents? Do the sizes of the vents meet the client's environment conditions in order to prevent tools, debris or dust from entering the cabinet? Please avoid the situation in Example 4. For additional details, please refer to Section 5.3.1.1 Ventilation requirements and the area of the vent opening.
- E. When calculating the total heat of all components inside the cabinet, please confirm if the temperature of the cabinet meets the requirement. Do the sizes and locations of the air vents provide sufficient air flow for internal heat dissipation? When multiple frequency converters are installed in a cabinet, please install cooling fans so that the temperature around the frequency converter can meet the requirements. For more details, please refer to 5.3.1.4 Design of multiple drives in the cabinet.
- F. Can the cabinet design protect the internal components and keep them from direct contact with water, moisture, or direct sunlight?
- G. Does the cabinet design leave enough space for routing wires and is the plan adequate and reasonable?
- H. Is the cabinet location sturdy and can the area support the weight of the entire cabinet?
- I. The location of the cabinet should be free of electromagnetic interference.
- J. Is there enough room at the location for proper machine operation and subsequent machine maintenance?

## 5.4.4 Installation and construction of the cabinet

- A. Please confirm that there are no corrosive liquids or gas near the cabinet location. The cabinet should be away from strong electric fields, strong magnetic fields, electric wave or heat source, and meets the required electromagnetic level of the machine room. (If any of the above is unavoidable, it is necessary provide protection to the cabinet.)

### Environment for Operation, Storage and Transportation

DO NOT expose the AC motor drive in the bad environment, such as dust, direct sunlight, corrosive/inflammable gasses, humidity, liquid and vibration environment. The salt in the air must be less than 0.01mg/cm<sup>2</sup> every year.

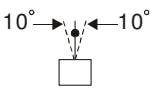
Environment	Installation location	IEC60364-1/IEC60664-1 Pollution degree 2, Indoor use only		
	Surrounding Temperature	Storage	-25 °C ~ +70 °C	
		Transportation	-25 °C ~ +70 °C	
			Non-condensation, non-frozen	
	Rated Humidity	Operation	Max. 95%	
		Storage/ Transportation	Max. 95%	
		No condense water		
	Air Pressure	Operation/ Storage	86 to 106 kPa	
		Transportation	70 to 106 kPa	
	Pollution Level	IEC721-3-3		
		Operation	Class 3C2; Class 3S2	
		Storage	Class 2C2; Class 2S2	
		Transportation	Class 1C2; Class 1S2	
No concentrate				
Altitude	Operation	If AC motor drive is installed at altitude 0~1000m, follow normal operation restriction. If it is install at altitude 1000~2000m, decrease 2% of rated current or lower 0.5 °C of temperature for every 100m increase in altitude. Maximum altitude for Corner Grounded is 2000m.		
Package Drop	Storage	ISTA procedure 1A(according to weight) IEC60068-2-31		
	Transportation			
Vibration	1.0mm, peak to peak value range from 2Hz to 13.2 Hz; 0.7G~1.0G range from 13.2Hz to 55Hz; 1.0G range from 55Hz to 512 Hz. Comply with IEC 60068-2-6			
Impact	IEC/EN 60068-2-27			
Operation Position	Max. allowed offset angle $\pm 10^\circ$ (under normal installation position)			

- B. The surrounding temperature and humidity should meet the long-term safety operation requirements of the equipment. The cleanliness of the machine room should meet the long-term safety operation requirements of the equipment. The machine room should have relevant fire safety equipment. The machine room should have corresponding anti-static measures.

- C. Do the frequency converter's mounting screws and their tightness comply with regulation?

For example:

Frame	Screw Size	Screw Torque
A	M5 [#10~#12]	25~30 Kg-cm[ 21.7~26 lb-in.]
B	M8 [5/16 in.]	40~45 Kg-cm[ 34.7~39.0 lb-in.]
C	M8 [5/16 in.]	50~55 Kg-cm[ 43.4~47.7 lb-in.]
D&D1	M10 [ 3/8 in.]	200~240 Kg-cm[ 173.6~208.3 lb-in.]
E&E1	M12 [ 1/2 in.]	300~350 Kg-cm [260.4~302.75 lb-in.]

D. Is the material for the power cord in accordance with the manual's specifications or at least compliant with the local regulations? (Only copper is allowed, using aluminum is prohibited; Splice is prohibited for all power cords. Excess wires should be trimmed after wiring. Coiling or twisting the wire is not allowed to prevent cords from overheating); Make sure all wires are connected to the corresponding terminal, the tightness and sequence are correct. Pull on the wire to check if it is secure. All wires are numbered and they are consistent with the wiring diagram.

For example, the manual's material selection of the wire follows UL (Underwriters Laboratories Inc): Main circuit terminals:

Main circuit terminals:  
R/L1, S/L2, T/L3, U/T1, V/T2, W/T3, +1/DC+, -/DC-

Frame F

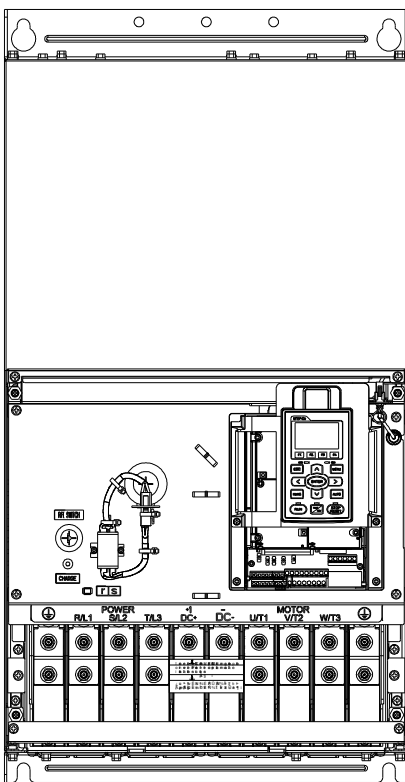

Models	Max. Wire Gauge	Min. Wire Gauge	Torque (±10%)
VFD900C23A	300MCM*2 (152mm <sup>2</sup> *2)	300MCM*2 (152mm <sup>2</sup> *2)	M8 200kg-cm (173 lb-in.) (19.62Nm)
VFD1320C43A		4/0 AWG*2 (107mm <sup>2</sup> *2)	
VFD1600C43A		300MCM*2 (152mm <sup>2</sup> )	
VFD900C23E	4/0 AWG*2 (107mm <sup>2</sup> *2)	4/0 AWG*2 (107mm <sup>2</sup> *2)	
VFD1320C43E		3/0AWG*2 (85mm <sup>2</sup> *2)	
VFD1600C43E		4/0 AWG*2 (107mm <sup>2</sup> *2)	

1. FD900C23A/E installations must use 90°C wire.
2. For other model, UL installations must use 600V, 75°C or 90°C wire. Use copper wire only.
3. Specification of grounding wire  $\oplus$  : 300MCM\*2 [152 mm<sup>2</sup>\*2]  
Torque: M8 200kg-cm (173 lb-in.) (19.62Nm) (±10%)
  1. Figure 1 shows the specification for ring lug.
  4. Figure 2 shows the specification of insulated heat shrink tubing that comply with UL (600V, YDPU2).

Figure 1

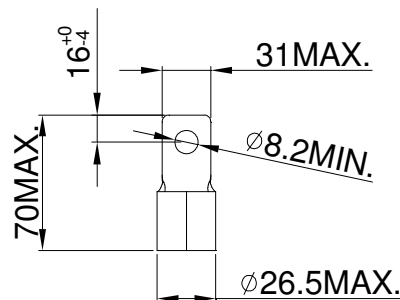
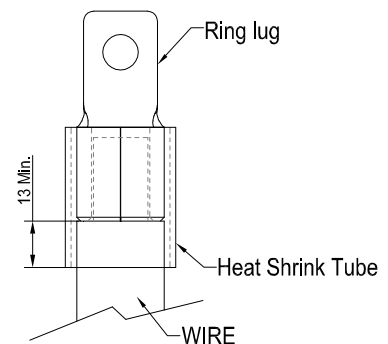

Figure 2



IEC (INTERNATIONAL ELECTROTECHNICAL COMMISSION) diameter conversion table:

**Table F. 1 – Standard cross-sections of round conductors**

ISO cross-section mm <sup>2</sup>	AWG/MCM	
	Size	Equivalent cross-section mm <sup>2</sup>
0,2	24	0,205
–	22	0,324
0,5	20	0,519
0,75	18	0,82
1,0	–	–
1,5	16	1,3
2,5	14	2,1
4,0	12	3,3
6,0	10	5,3
10	8	8,4
16	6	13,3
25	4	21,2
35	2	33,6
50	0	53,5
70	00	67,4
95	000	85,0
–	0000	107,2
120	250 MCM	127
150	300 MCM	152
185	350 MCM	177
240	500 MCM	253
300	600 MCM	304

NOTE: The dash, when it appears, counts as a size when considering connecting capacity (see 4.3.8.8.2)

E. Is the color of the grounding wire (earth wire) green or yellow green? Are they connected to the corresponding terminals and are the terminals tightly screwed? (Check by pulling the conductor) Spray paint is not allowed near the locks. The equipment rack and equipment with full and partial metal housing should be properly grounded. All groundings should be interconnected so that they can be connected to the client's grounding plate.

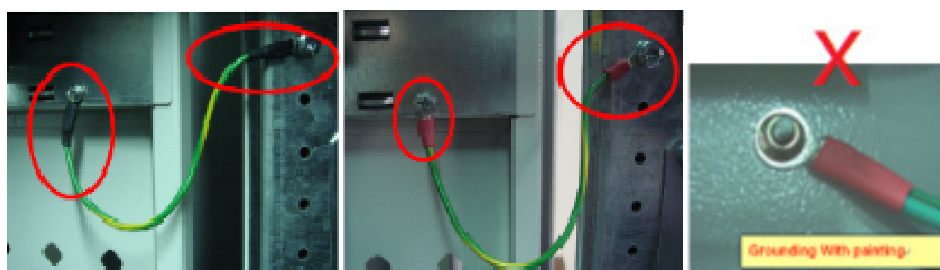

F. The bus system is designed to accommodate the final maximum load; therefore, it is necessary to confirm the temperature impact of the bus inside the cabinet and whether the bus has protection against accidental contact.

G. If it is required to plug in, remove or touch the PCB during construction, the construction workers should wear electrostatic rings or static gloves to meet the safety standards of anti-static operation.

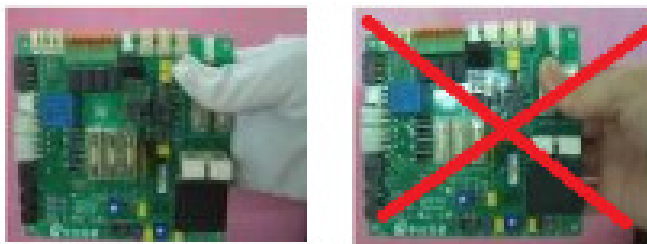

- H. The internal components and separation material must be non-flammable.
- I. Confirm if the insulation distance of the conductor within the cabinet is kept at a minimum safe distance of 14mm. If the distance is insufficient, a separation material that can withstand 5000V AC and is non-combustible can be used. Ex: Insulation sheet or heat shrinking sleeve.
- J. Verify if the internal routing are correct, and if there are scratch-resistant mechanisms set up at areas where wires pass through, to avoid damaging the wires. The routing of the signal wires in the cabinet should be planned properly, for example, the motor wires and signal wires should be separated as much as possible to avoid interference.

Before wiring, a continuity test should be performed for each signal wire. The signal wires cannot pass through the cabinet's heat dissipation holes. Cables should be organized and spaced evenly with proper tightness and neat wire clips. The extra parts should be cut off and leave no sharp points. The signal wire outside of the cabinet should be protected with a protective sleeve or by going through a channel. The protective sleeve should extend into the interior of the cabinet, and the casing should be bound and secured. The ends of the protective tube should be smooth, or wrapped with insulation tape to prevent potential injuries. The signal wire area should be clear of other cables or objects on top. The signal cable should be smooth when going around the corners. When it is fixed to an angular structure, necessary protective measures should be taken.

### 5.1.3 Fixation of wire harness



Figure 5.1.3-1



Figure 5.1.3-2

#### Targets

- 5.1.3.1 Tie point must be neat, tight, and maintain a certain distance, make the wire fixed in the firming wire harness. (Figure 5.1.3-1)
- 5.1.3.2 If wire harness is composed by two or more wires, must use winding pipe to wrapped it well. (Figure 5.1.3-2)

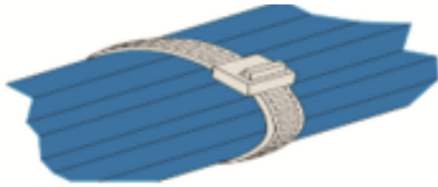

Figure 5.1.3-3



Figure 5.1.3-4

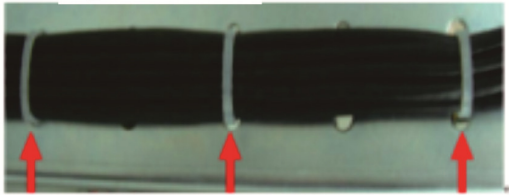

Figure 5.1.3-5

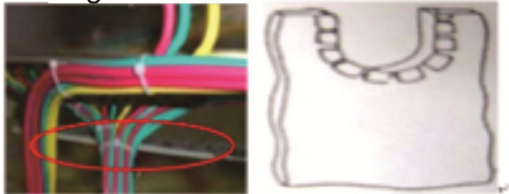

Figure 5.1.3-6

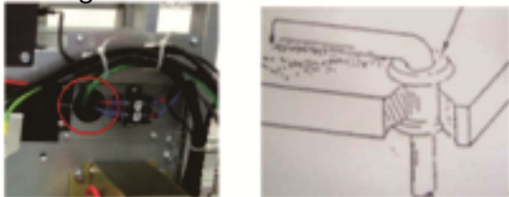

Figure 5.1.3-7

5.1.3-3 Requirements of tie end:  
(Figure 5.1.3-3)

- A. Tie cut surface must parallel to cable tie knot surface;
- B. The length of tie end extends not less than a caliper, and no more than three calipers;

5.1.3-4 Requirements when wire harness forked: (Figure 5.1.3-4)

- A. There must be cable ties at both ends when wire harness forked;
- B. The wire must be fixed in the wire harness;
- C. Nowhere be tied is damaged or broken.

5.1.3-5 Spacing provision of wire harness :  
(Figure 5.1.3-5)

- A. Tying once about every 50-100mm in power cell, try to make equal spacing;
- B. The whole cabinet, tying once about every 200-250mm vertically and every 150-200mm horizontally, try to make equal spacing;

5.1.3-6 In gravity situation, if the wire is contacted with sharp metal edges, it should increase wire elastic material such as rubber protection. (Figure 5.1.3-6)

5.1.3-7 When wire passes through metal vias, the vias need for protection. (Figure 5.1.3-7)



### 5.1.5 Wiring - Wire cross



Figure 5.1.5-1

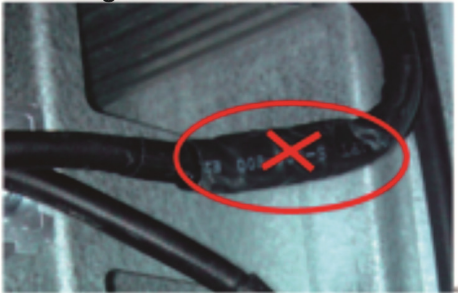

Figure 5.1.5-2



Figure 5.1.5-3



Figure 5.1.5-4



Figure 5.1.5-5

### Targets

- 5.1.5.1 Place each wire basic parallel to the wire harness axis, no cross. (Figure 5.1.5-1)
- 5.1.5.2 Try to make wire harness configuration be horizontal and verticals, and neat appearance.
- 5.1.5.3 Signal lines, high-voltage line, (more than 380V), low-voltage line (less than or equal 380V) must separate the wiring, do not crossover unless vertical.
- 5.1.5.4 Prohibit the use of welding or gluing way to make extension lead. (Figure 5.1.5-2)

### Acceptable

- 5.1.5.5 Wire harness allows not more than one wire to intersect. (Figure 5.1.5-3)

### Rejection

- 5.1.5.6 Signal lines, high-voltage line (more than 380V) and low-voltage line (less than or equal 380V) bundled together. (Figure 5.1.5-4)
- 5.1.5.7 Within the wire harness, over one or more wire intersect. (Figure 5.1.5-5)

- K. Check the model number and labels to confirm the consistency of the power source's voltage and the rated voltage of the frequency converter.
- L. Any construction near the area should ensure that no metal debris fall into the cabinet.
- M. If the cabinet top or door can be fully shut to provide the proper protection.
- N. The cabinet should be installed in an upright position, without being tilted. If it is tilted, the angle should not exceed 10 degrees.
- O. Seal all cabinet wiring holes after the wirings are done.

- P. If all operational components and switches in the cabinet are labeled properly for easy operation and maintenance.
  - Q. After assembly is completed, please check if the wiring holes of the cabinet are properly sealed, and there are no wire clips, screws or any other objects on the cabinet floor. Any spare parts should be neatly stacked. The signal expansion cable should be tied up or secured at the reserved space inside the cabinet for easy maintenance and to prevent misplacement. Protective measures such as protection caps should be adopted for unused plugs.
  - R. Appropriate working space should be allocated for proper operation and maintenance inside the cabinet.
2. Confirmation upon completion:
- A. All screws should be tightened and all insulation should be in place; if the installation of the cabinet is perpendicular to the ground; if it is tilted, are the angle less than 10 degrees; if the working voltage of the frequency converter is consistent with the voltage of the main power source.
  - B. All moving parts and cabinet switches operate normally.
  - C. Make sure all the phase of the wiring is correctly installed in accordance with the wiring diagram, nothing is loose, and the grounding wire is properly connected. No miscellaneous objects inside the cabinet.
  - D. If the wiring holes in the cabinet are sealed properly and the flow passage in the cabinet is unobstructed.
  - E. All routing of the wires in the cabinet are correct; and proper protective measures are in place. For example: Sleeve or wire casing.
  - F. Protective measures such as protection caps should be adopted for unused plugs.
  - G. Check if all insulation materials are undamaged.
  - H. Check if there is any damage or deformation to all components.
  - I. If the wiring diagram of the cabinet is properly displayed on the cabinet.

## 6 Load reduction and overload curves

### 6.1 The load reduction curve of the ambient temperature

#### 6.1.1 Environmental load reduction curve during general use

(General use refers to the V/F, SVC, IMFOCPG, V/FPG and PMSVC control modes)

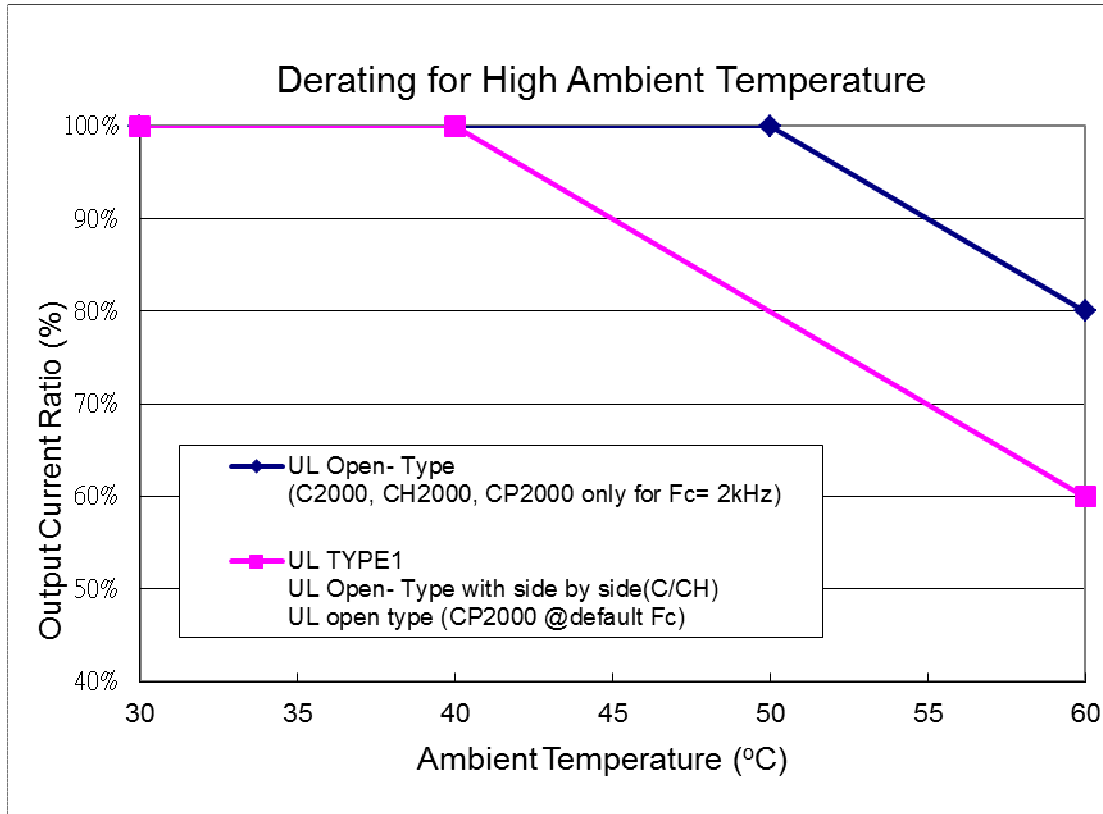

Figure 6.1.1

### 6.1.2 Environmental load reduction curve during advanced application

(Advanced application refers to IMFOC Sensorless, PMFOC Sensorless, PMFOCPG, IMTQCPG, PMTQCPG and IMTQC Sensorless control modes.)

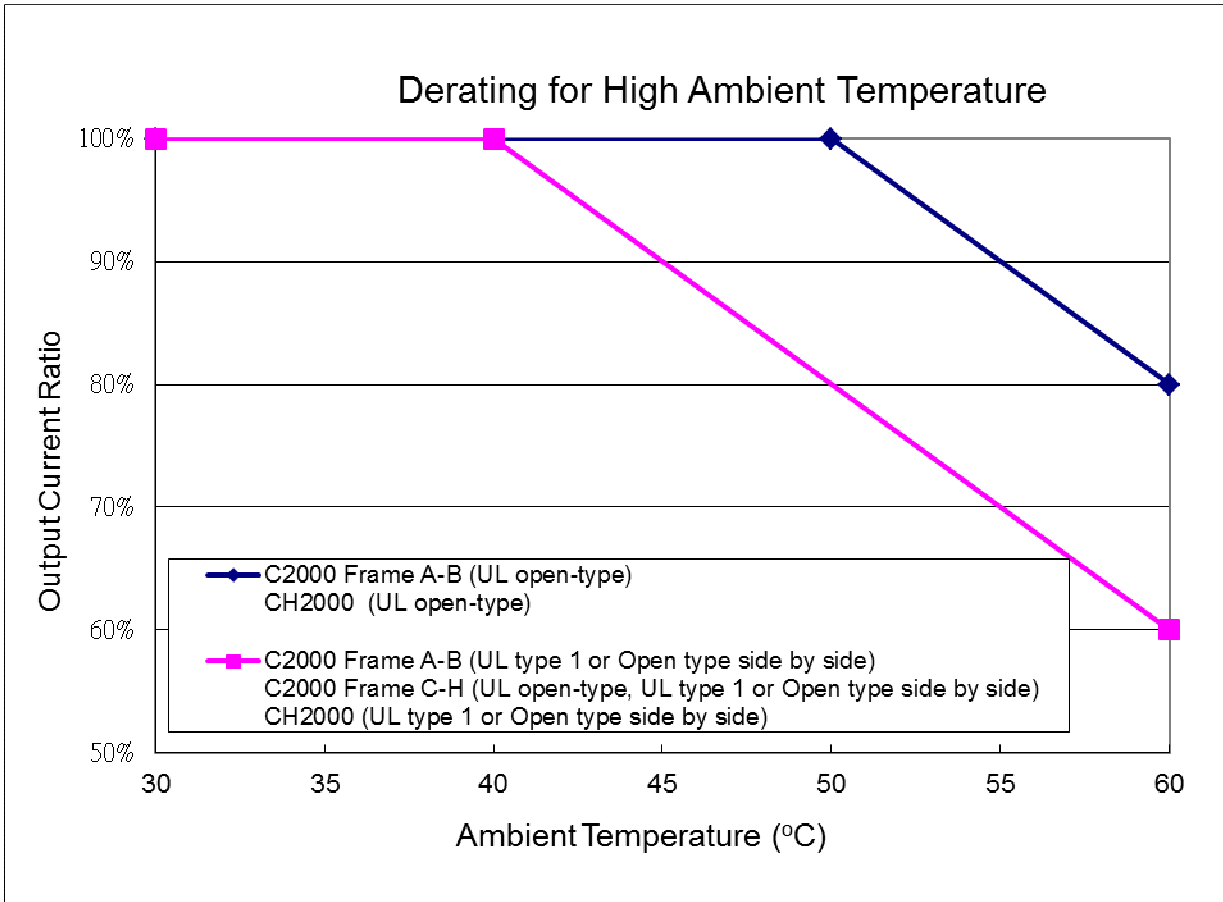
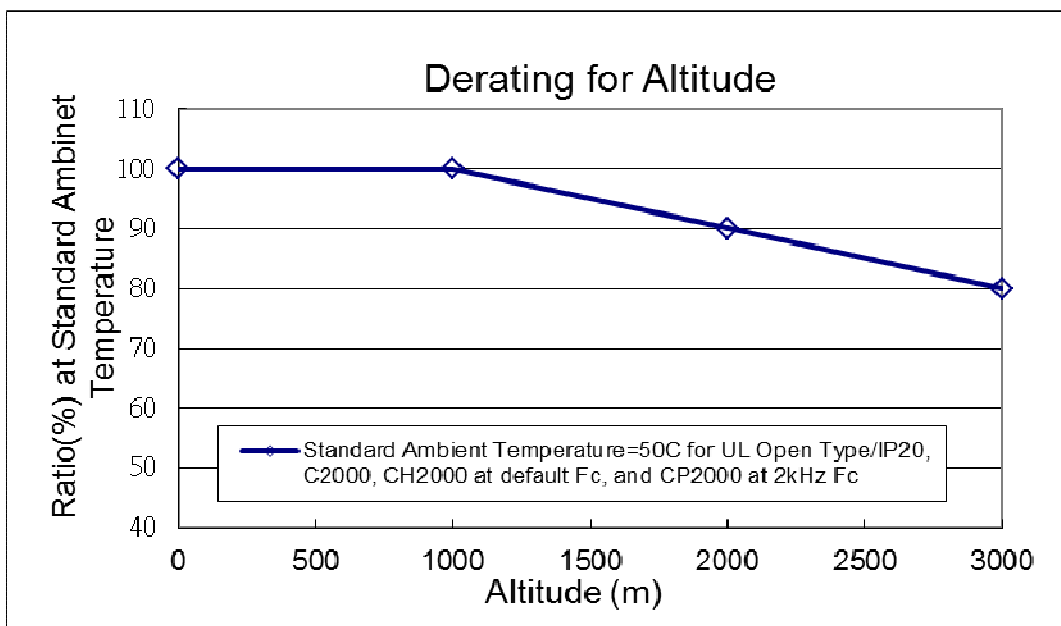

Figure 6.1.2 Environmental load reduction curve during advanced application

## 6.2 Load reduction curve of altitude



Operating altitude above sea level	Current derating at ambient temperature (inlet air temperature)				
	30°C	35°C	40°C	45°C	50°C
m	20°C	25°C	30°C	35°C	40°C
0-1000					
1001-1500					95%
1501-2000					90%
2001-2500				95%	85%
2501-3000				90%	80%
3001-3500			95%	85%	75%
3501-4000			90%	80%	70%
4001-4500		95%	85%	75%	65%
4501-5000		90%	80%	70%	60%

Table 6.2 Load reduction of altitude

## 6.3 The load reduction curve of carrier wave

### 6.3.1 Load reduction curve of C2000

- General use

(General use refers to the V/F, SVC, IMFOCPG, V/FPG and PMSVC control modes)

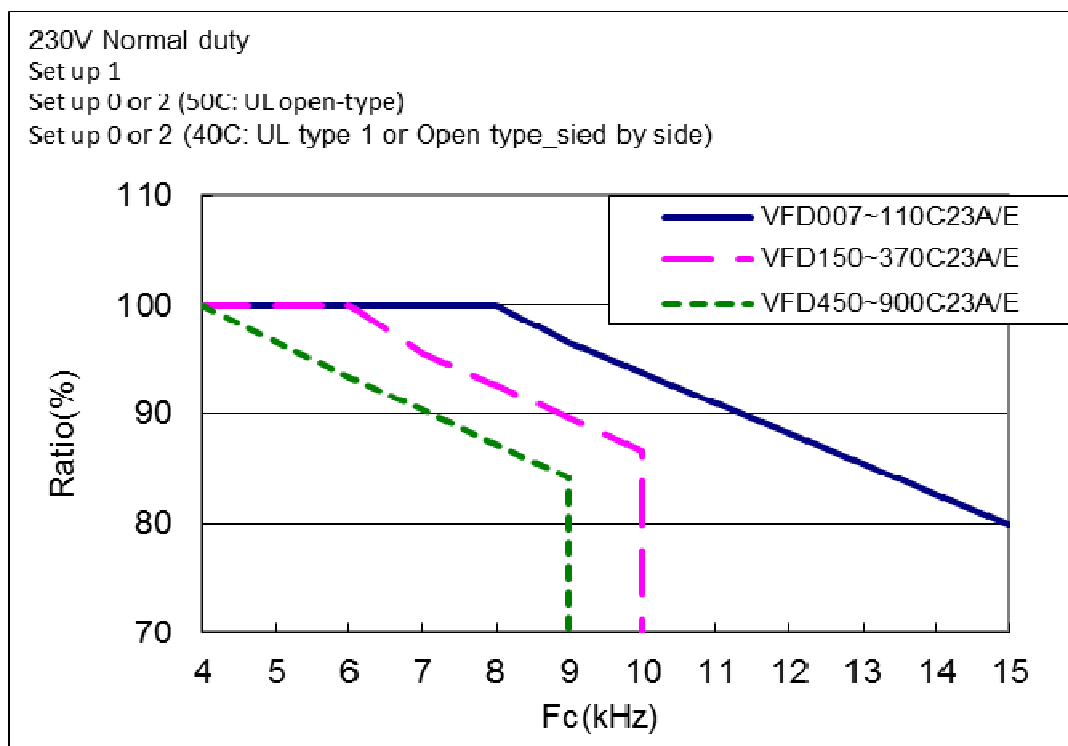
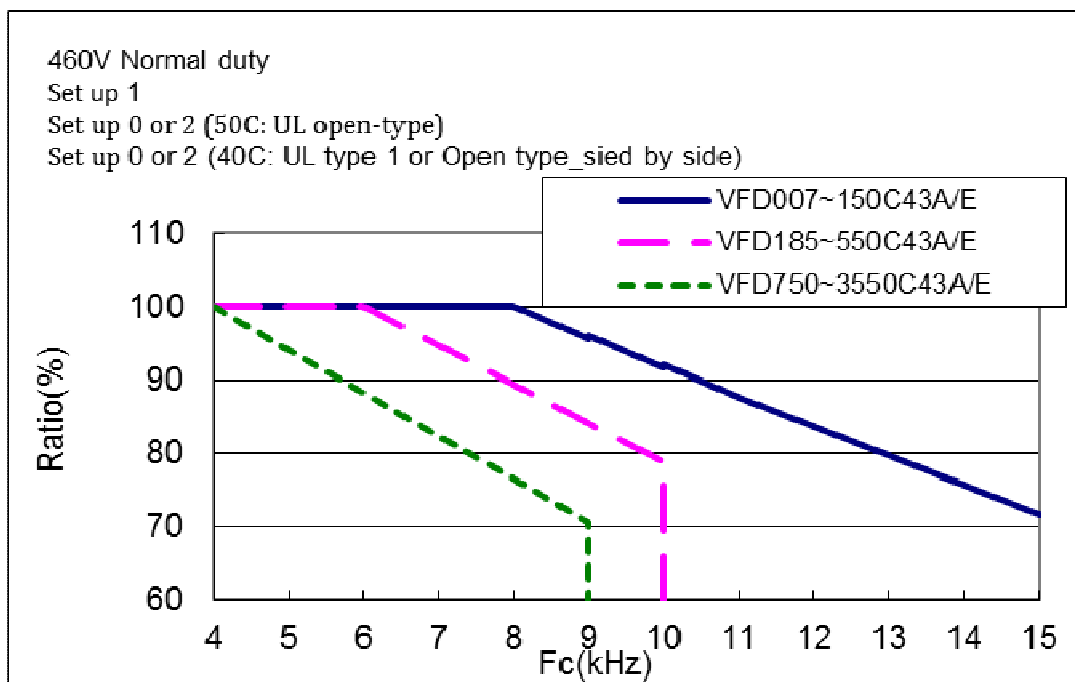

Figure 6.3.1-1 Load reduction curve of C2000 ND general use

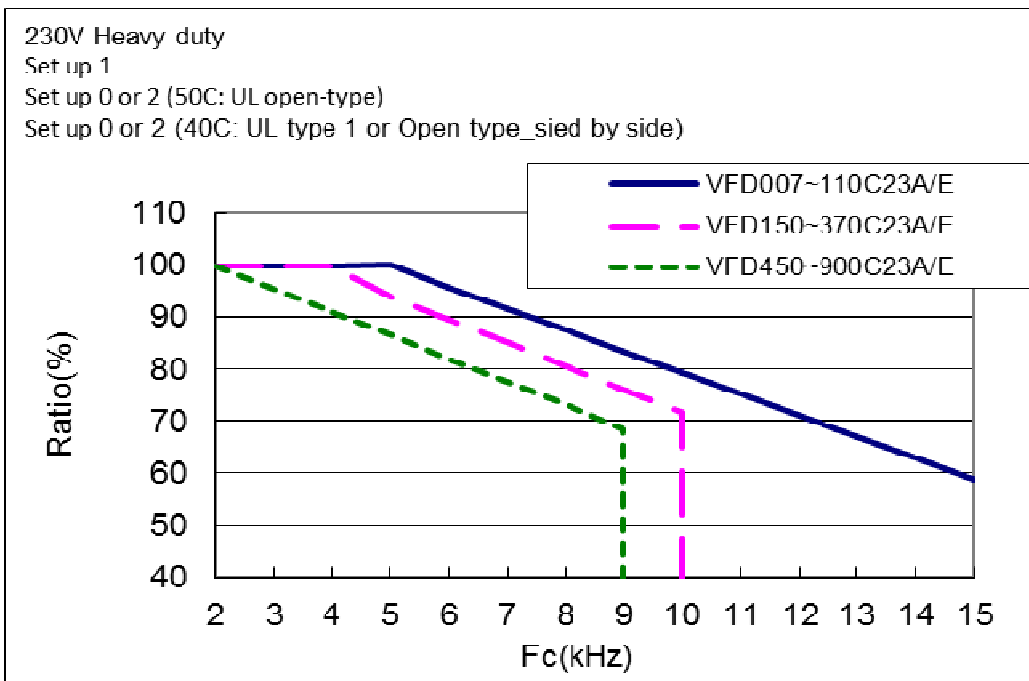
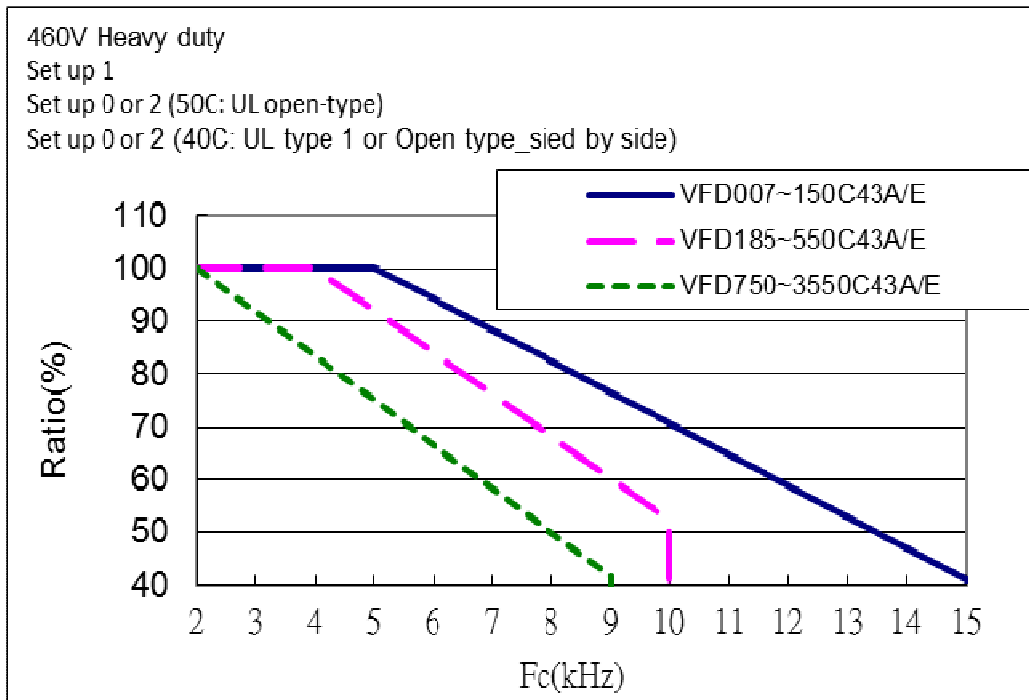

Figure 6.3.1-2 Load reduction curve of C2000 HD general use

- Advanced Applications

(Advanced application refers to IMFOC Sensorless, PMFOC Sensorless, PMFOCPG, IMTQCPG, PMTQCPG and IMTQC Sensorless control modes.)

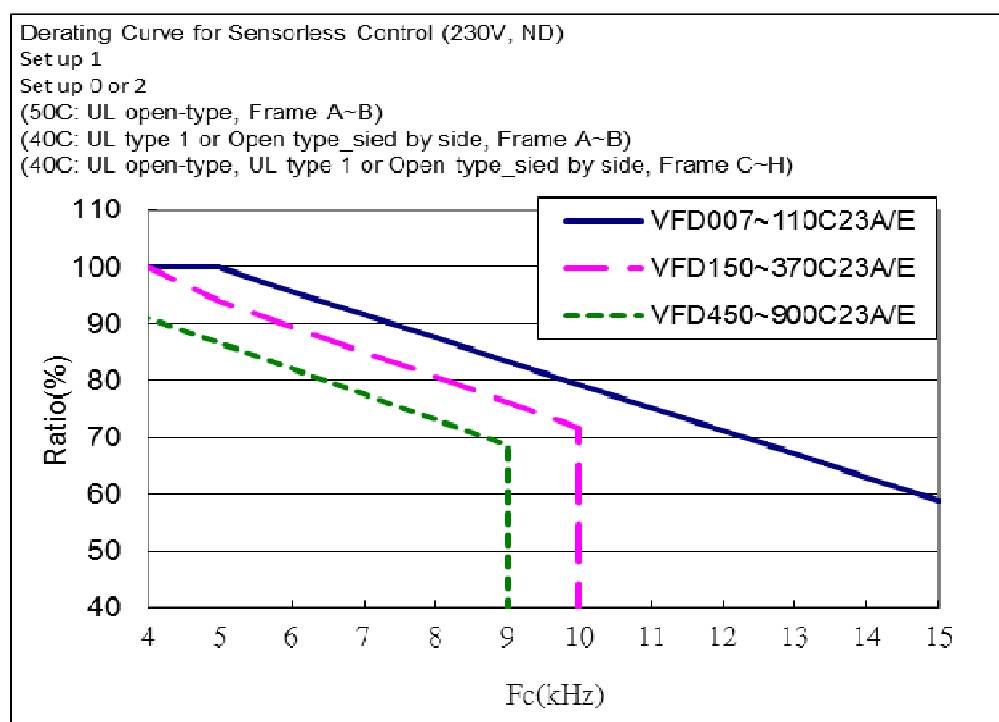
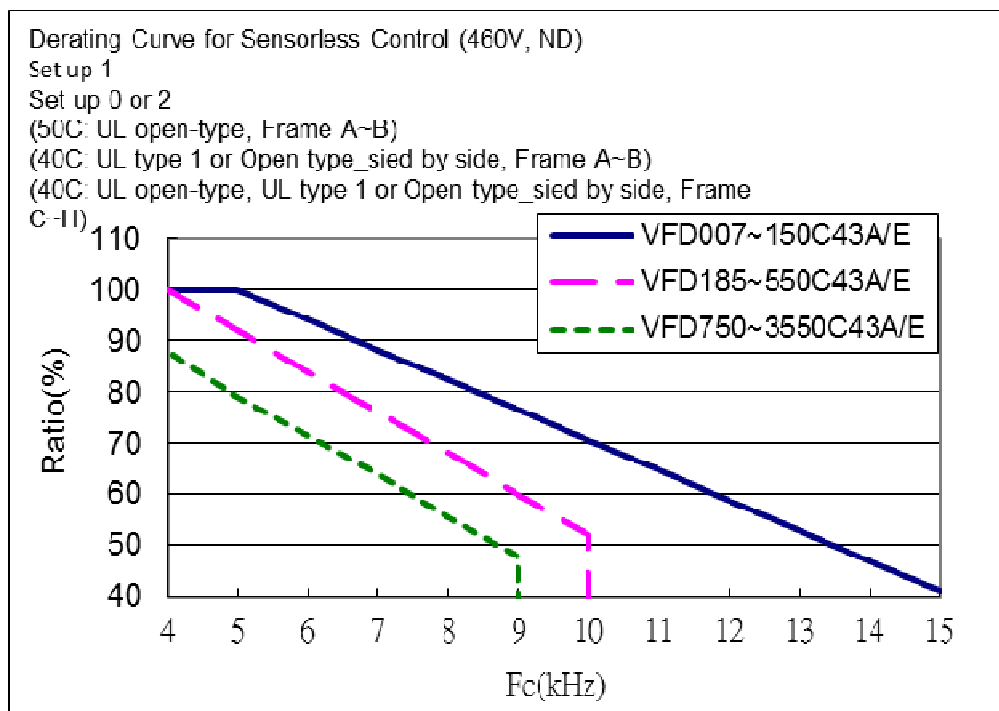

Figure 6.3.1-3 Load reduction curve of C2000 ND advanced applications



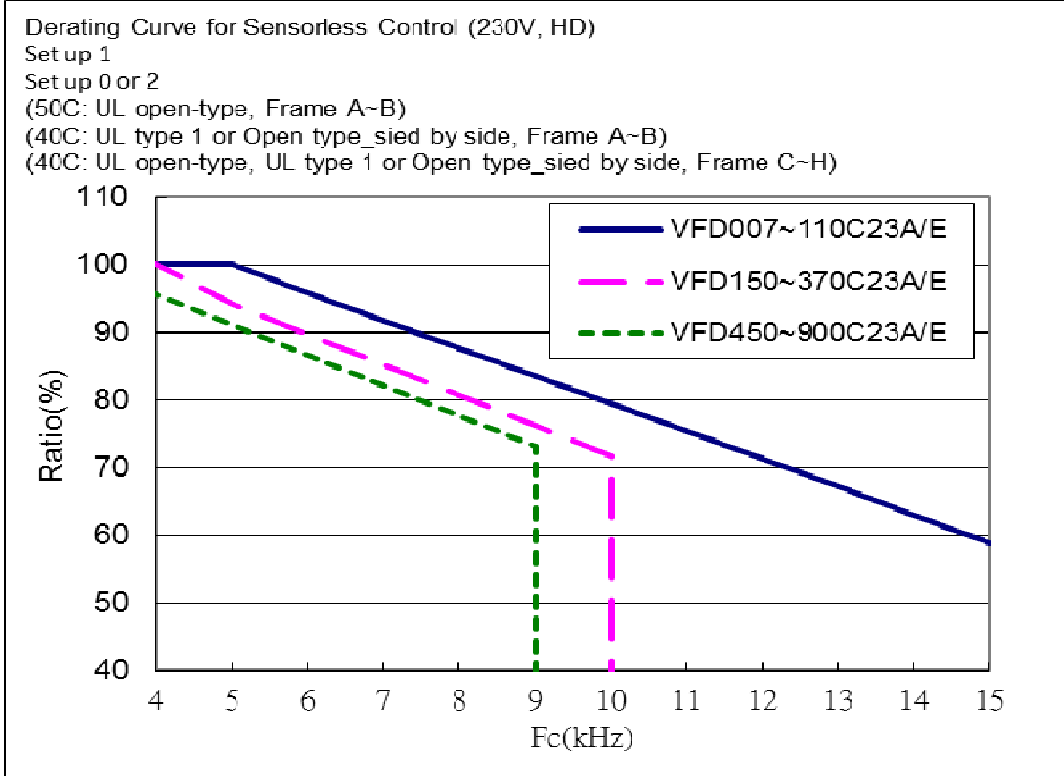
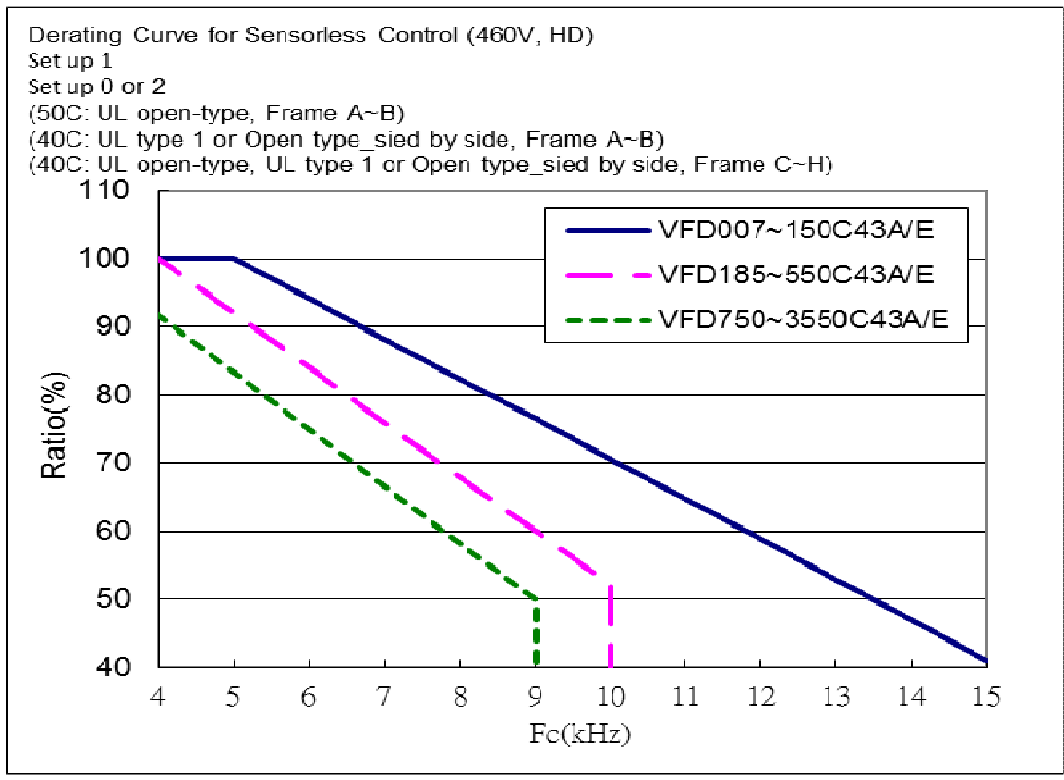

Figure 6.3.1-4 Load reduction curve of C2000 HD advanced applications

### 6.3.2 Load reduction curve of CH2000

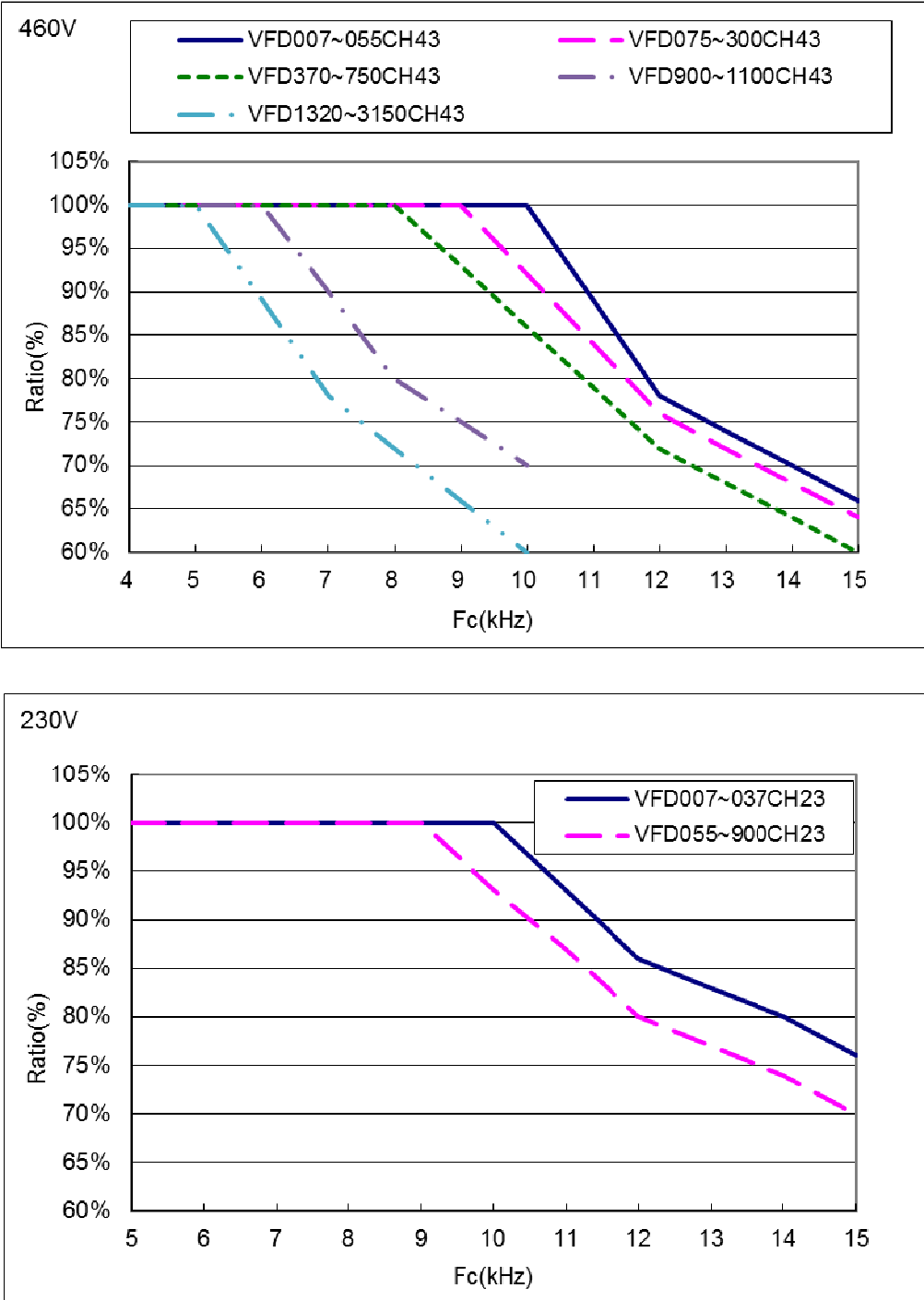

Figure 6.3.2-1 Load reduction curve of CH2000

### 6.3.3 Load reduction curve of CP2000

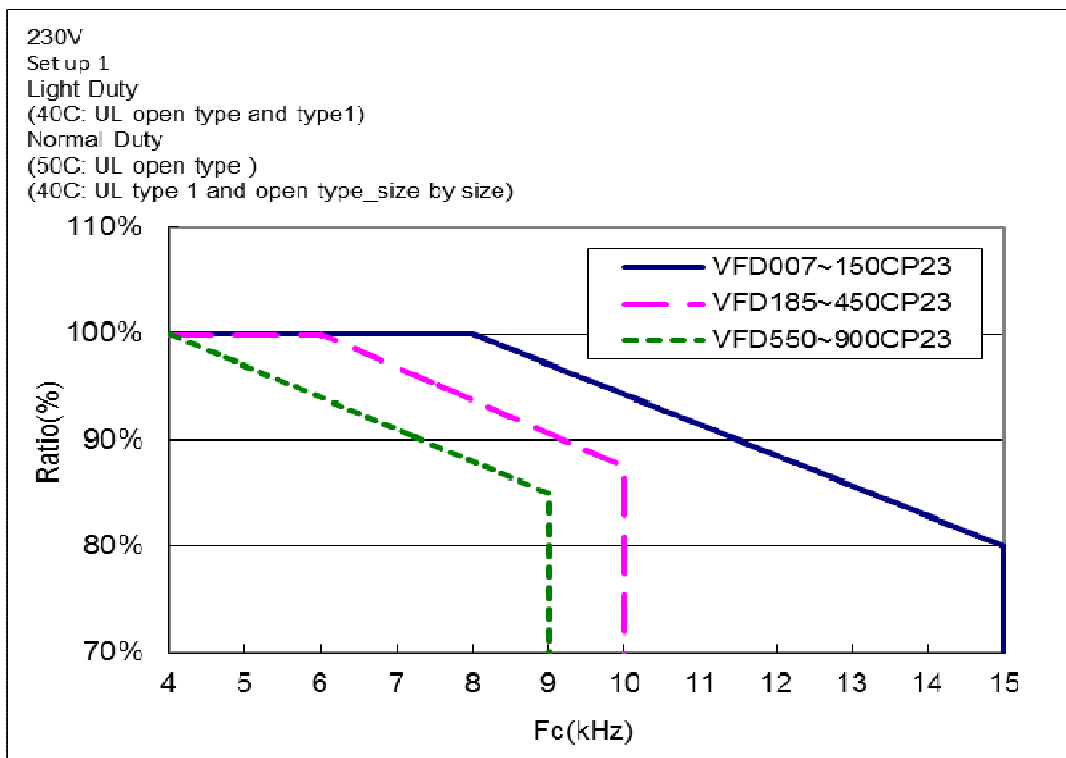
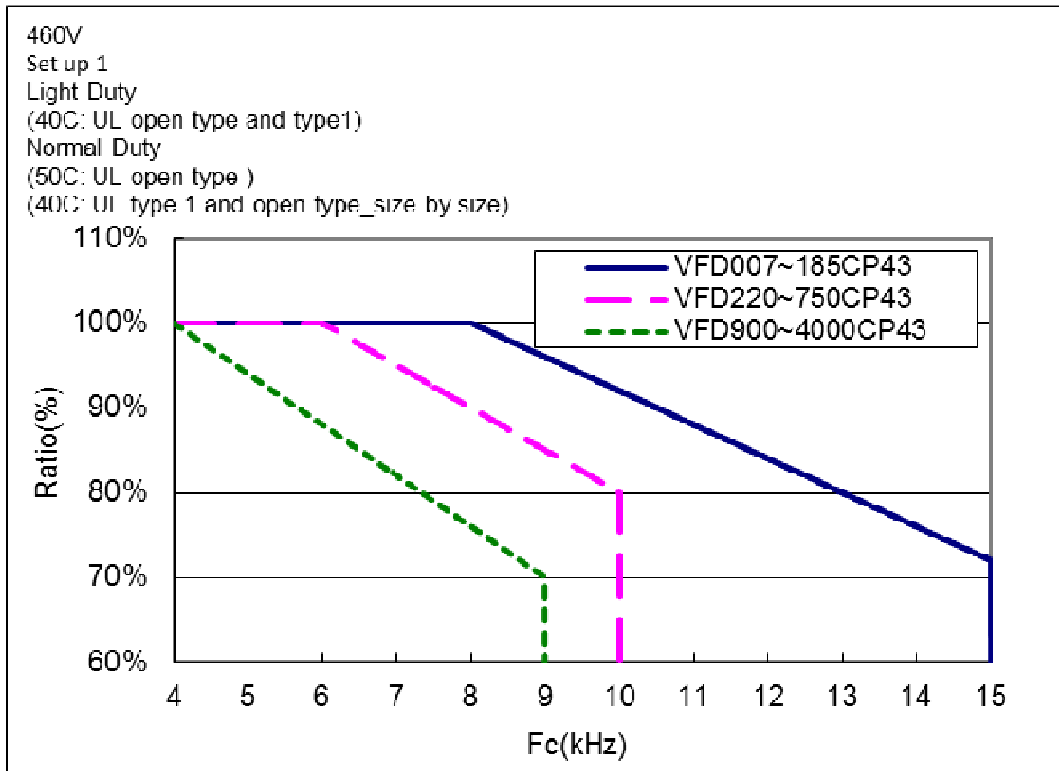

Figure 6.3.3-1 Load reduction curve of CP2000

## 6.4 Overload curves

### 6.4.1 Overload curves

The C series frequency converter has a certain overload capacity. The relationship of the condition of overload, overload and the overload time are shown in the curve below.

- The overload curve of C2000 series is shown in Figures 6.4.1-1(ND) and 6.4.1-2(HD).
  - Figure 6.4.1-1(ND):120% overload can supply 60 seconds; 160% overload can supply 3 seconds.

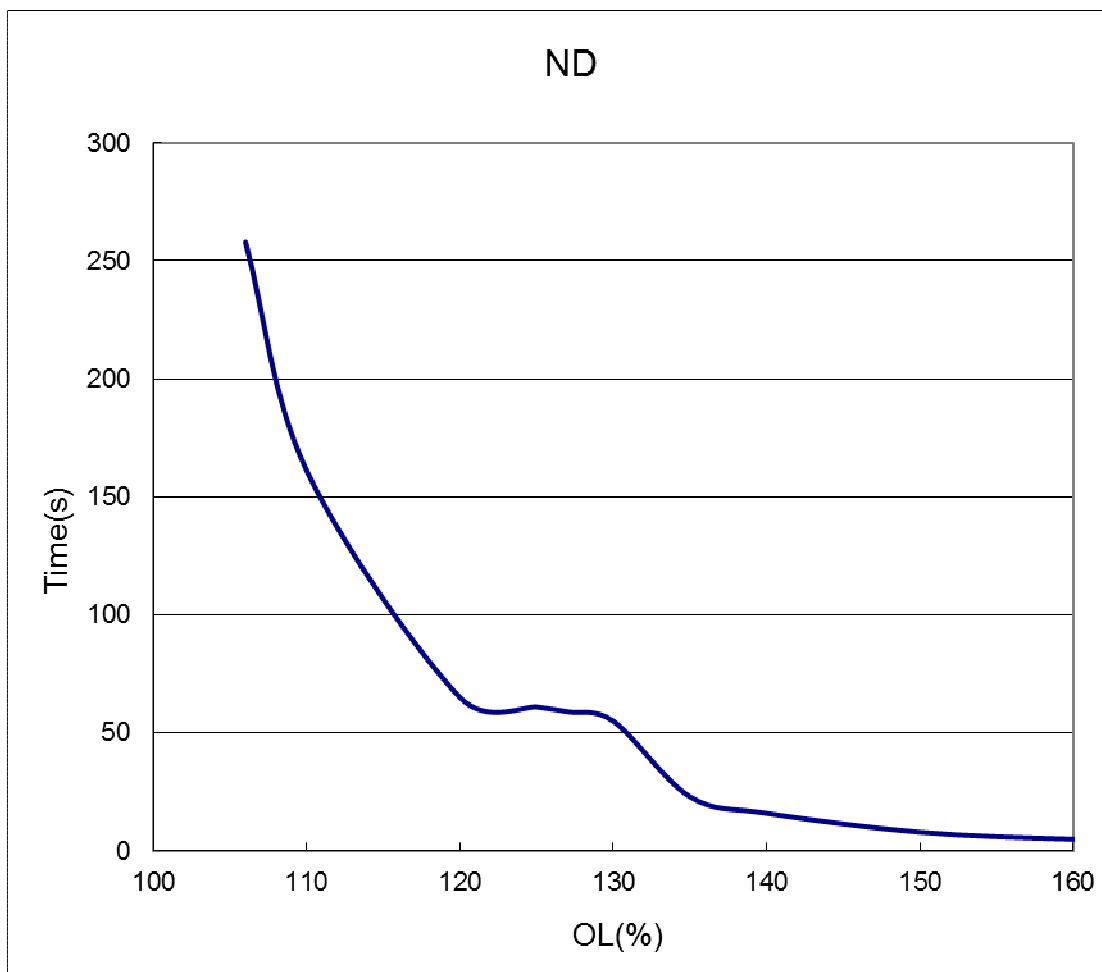

Figure 6. 4.1-1 Overload curve of C2000 ND

- Figure 6.4.1-2(HD):150% overload can supply 60 seconds; 180% overload can supply 3 seconds.

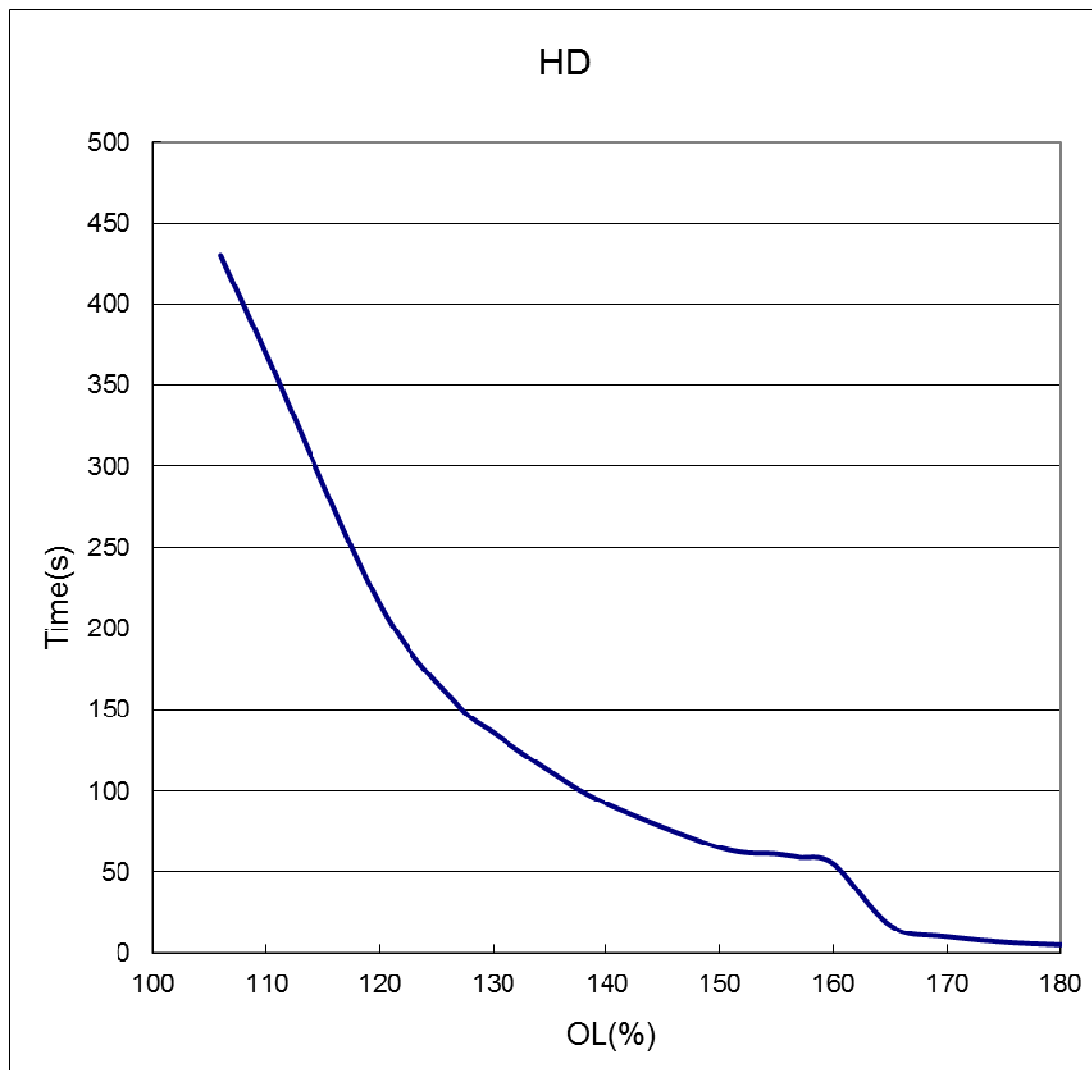

Figure 6. 4.1-2 Overload curve of C2000 HD

- The overload curve of the CH2000 series is shown in Figures 6.4.1-3. 150% overload can supply 60 seconds; 200% overload can supply 3 seconds.

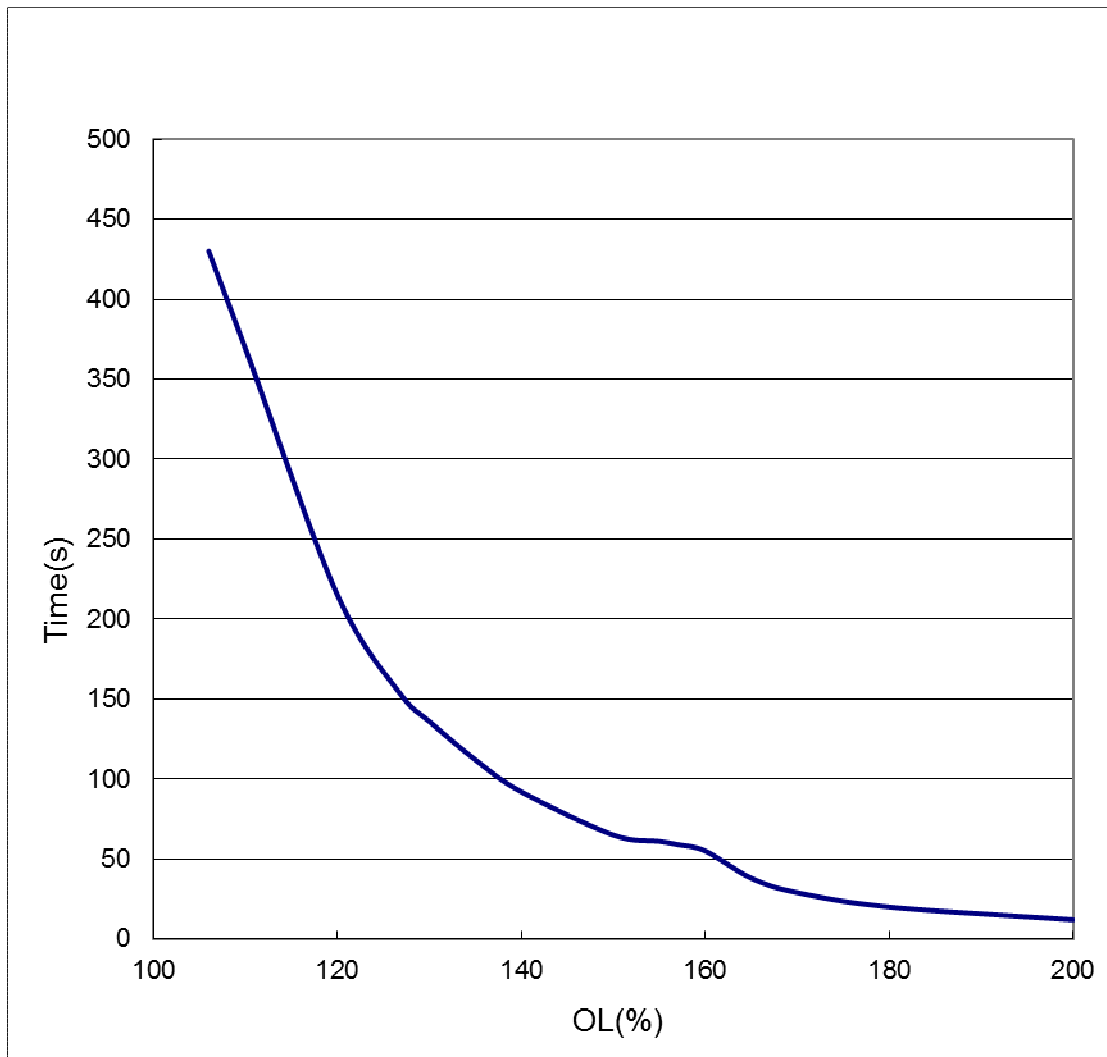

Figure 6. 4.1-3 Overload curve of CH2000

- The overload curves of the CP2000 series is shown in Figures 6.4.1-4(LD) and 6.4.1-5(ND).
  - Figure 6.4.1-4(LD): 120% overload can supply 60 seconds.

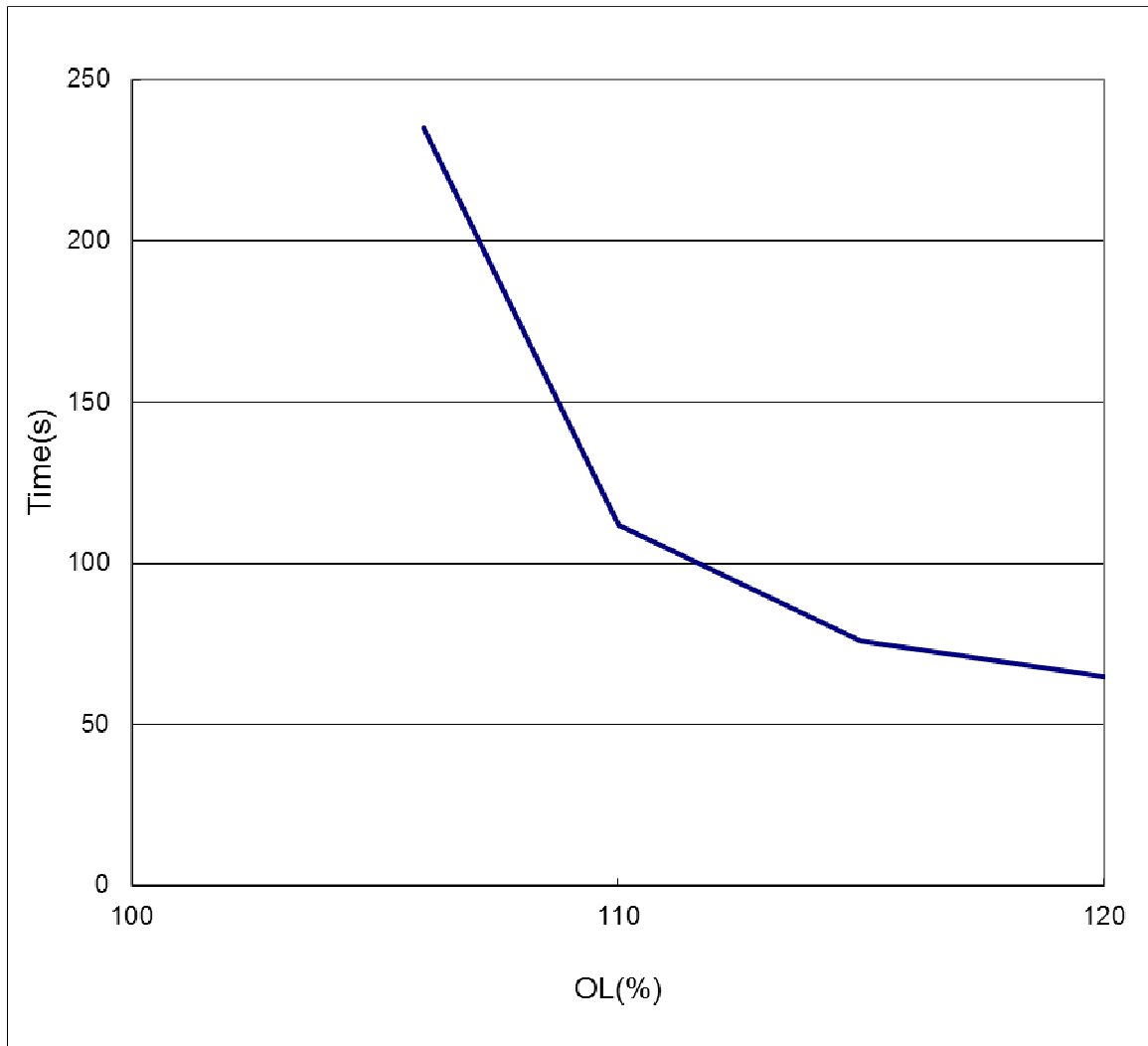

Figure 6. 4.1-4 Overload curve of CP2000 LD

- Figure 6.4.1-5(ND):120% overload can supply 60 seconds; 160% overload can supply 3 seconds.

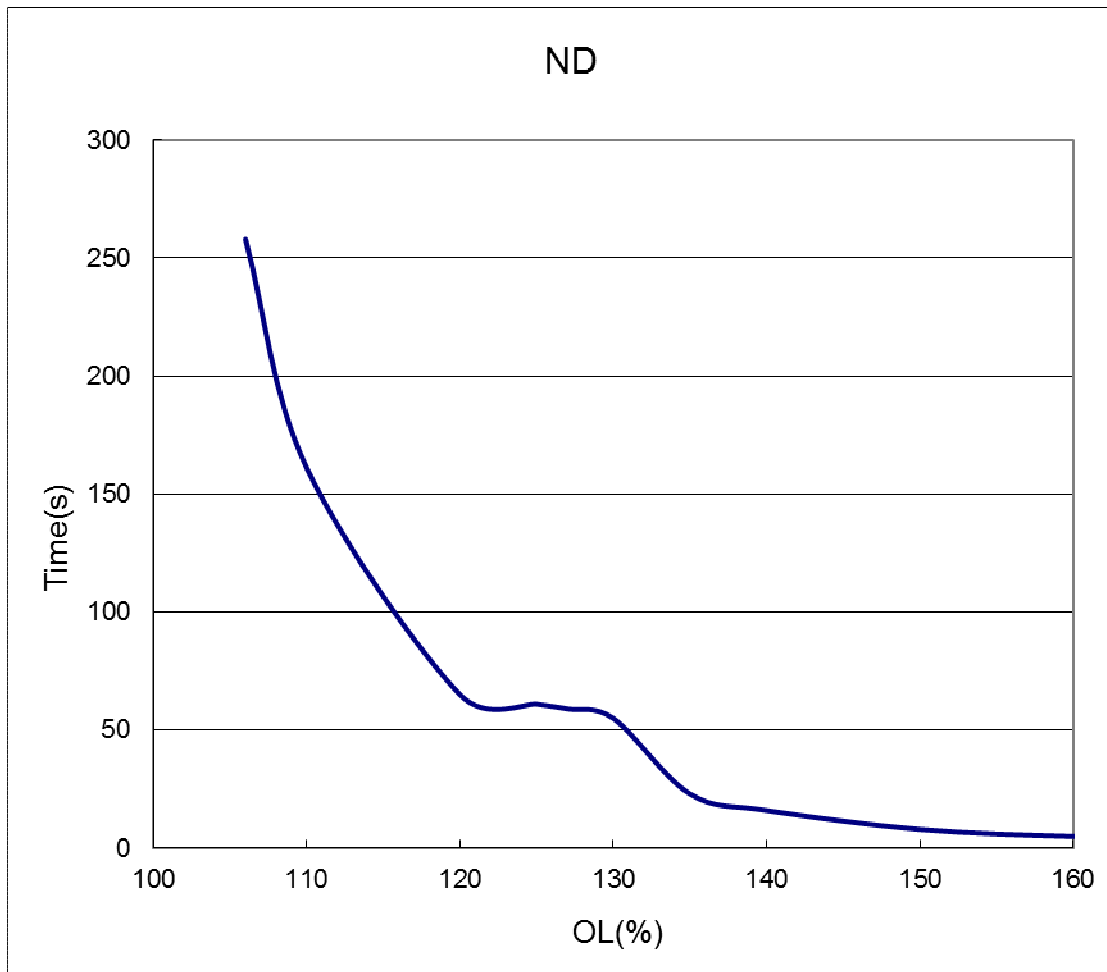

Figure 6. 4.1-5 Overload curve of CP2000 ND



## 6.4.2 The recovery time from an overload

For C series frequency converters, under any overload circumstances, a certain amount of time to eliminate the accumulated energy is required. When the energy is accumulated to a certain level, it may trigger the OL protection warning. Thus, under continuous overload, please pay attention to the time required for energy elimination. The following are the length of time required for energy elimination under overload conditions.

- The recovery time from an overload of C2000 series :
  - ND :

Operating conditions for continuous overload	Under 100% load, the required time (in seconds) for elimination of accumulated energy	Under 50% load, the required time (in seconds) for elimination of accumulated energy	Under 0% load, the required time (in seconds) for elimination of accumulated energy
120% OL, 60 seconds	240	57	17
160% OL, 3 seconds	33	8	2

Table 6.4.2-1 The recovery time from an overload of C2000 ND

- HD :

Operating conditions for continuous overload	Under 100% load, the required time (in seconds) for elimination of accumulated energy	Under 50% load, the required time (in seconds) for elimination of accumulated energy	Under 0% load, the required time (in seconds) for elimination of accumulated energy
150% OL, 60 seconds	240	57	17
180% OL, 3 seconds	27	6	2

Table 6.4.2-2 The recovery time from an overload of C2000 HD

- The recovery time from an overload of CH2000 series :

Operating conditions for continuous overload	Under 100% load, the required time (in seconds) for elimination of accumulated energy	Under 50% load, the required time (in seconds) for elimination of accumulated energy	Under 0% load, the required time (in seconds) for elimination of accumulated energy
150% OL, 60 seconds	240	57	17
200% OL, 3 seconds	79	19	6

Table 6.4.2-3 The recovery time from an overload of CH2000

- The recovery time from an overload of CP2000 series :

➤ LD :

Operating conditions for continuous overload	Under 100% load, the required time (in seconds) for elimination of accumulated energy	Under 50% load, the required time (in seconds) for elimination of accumulated energy	Under 0% load, the required time (in seconds) for elimination of accumulated energy
120% OL, 60 seconds	240	57	17

Table 6.4.2-4 The recovery time from an overload of CP2000 LD

➤ ND :

<b>Operating conditions for continuous overload</b>	<b>Under 100% load, the required time (in seconds) for elimination of accumulated energy</b>	<b>Under 50% load, the required time (in seconds) for elimination of accumulated energy</b>	<b>Under 0% load, the required time (in seconds) for elimination of accumulated energy</b>
120% OL, 60 seconds	240	57	17
160% OL, 3 seconds	33	8	2

Table 6.4.2-5 The recovery time from an overload of CP2000 ND

## 7 Brake Module and Brake Resistor

For a general operating cycle of motor, consist of acceleration, constant speed, and deceleration. The profiles of torque to current, rotation speed to voltage, and mechanical power to electrical power are similar. When the value of power is negative, the system becomes regenerative mode. The brake module must transfer the power into brake resistor, and avoid additional power breaking the drive.

## 7.1 Selection Flow

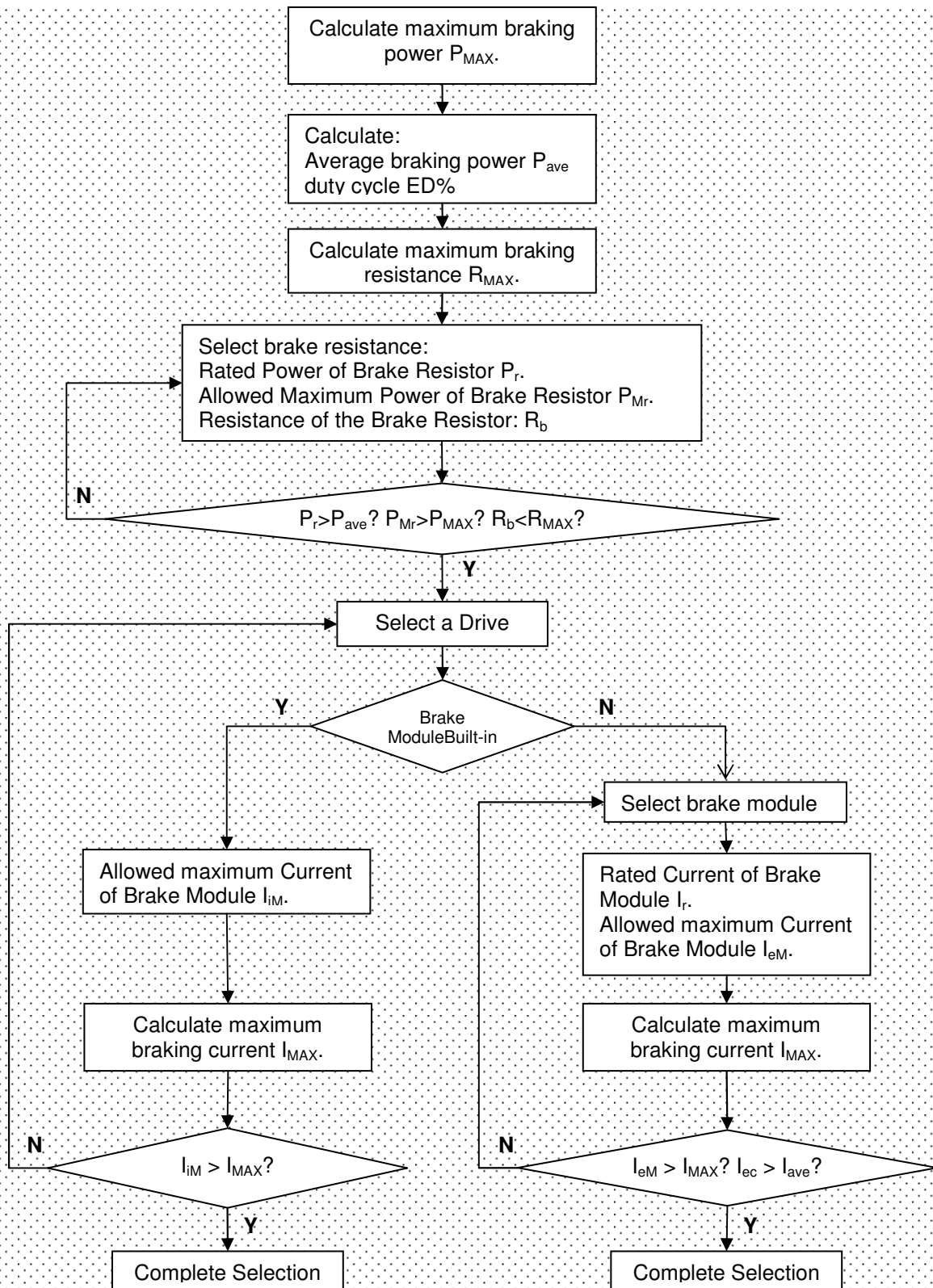

There are 2 conditions in different operation of motor. The following calculations based on these 2 conditions. Rotation speed of motor is accelerating in time 0 to  $t_1$ , constant speed in  $t_1$  to  $t_2$ , decelerating in  $t_2$  to  $t_3$ , rest in  $t_3$  to  $t_4$ .

**Condition 1:** Constant rotation speed with positive torque. A drive operates in regenerative mode when the rotation speed decreases, shown in Figure 7.1-1.

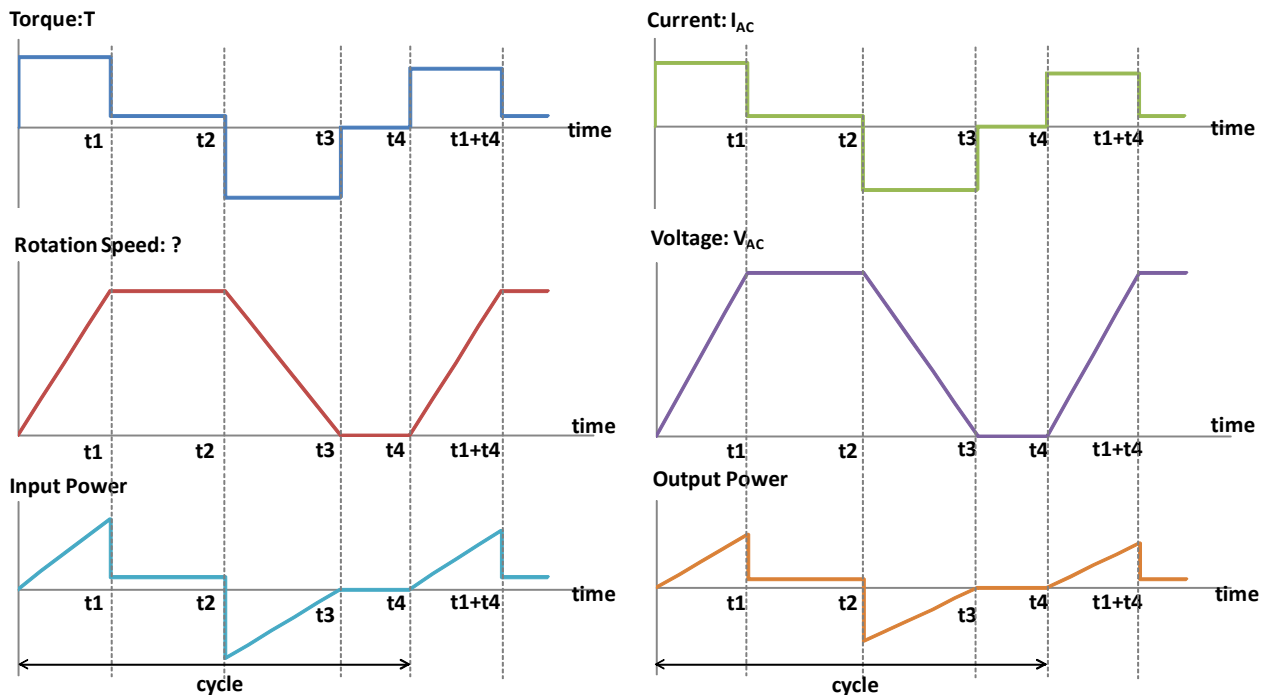

Figure 7.1-1 General cycle of motor : Constant rotation speed with positive torque.

**Condition 2:** Constant rotation speed with negative torque. A drive operates in regenerative mode when the rotation speed is constant and decreases, shown in Figure 7.1-2

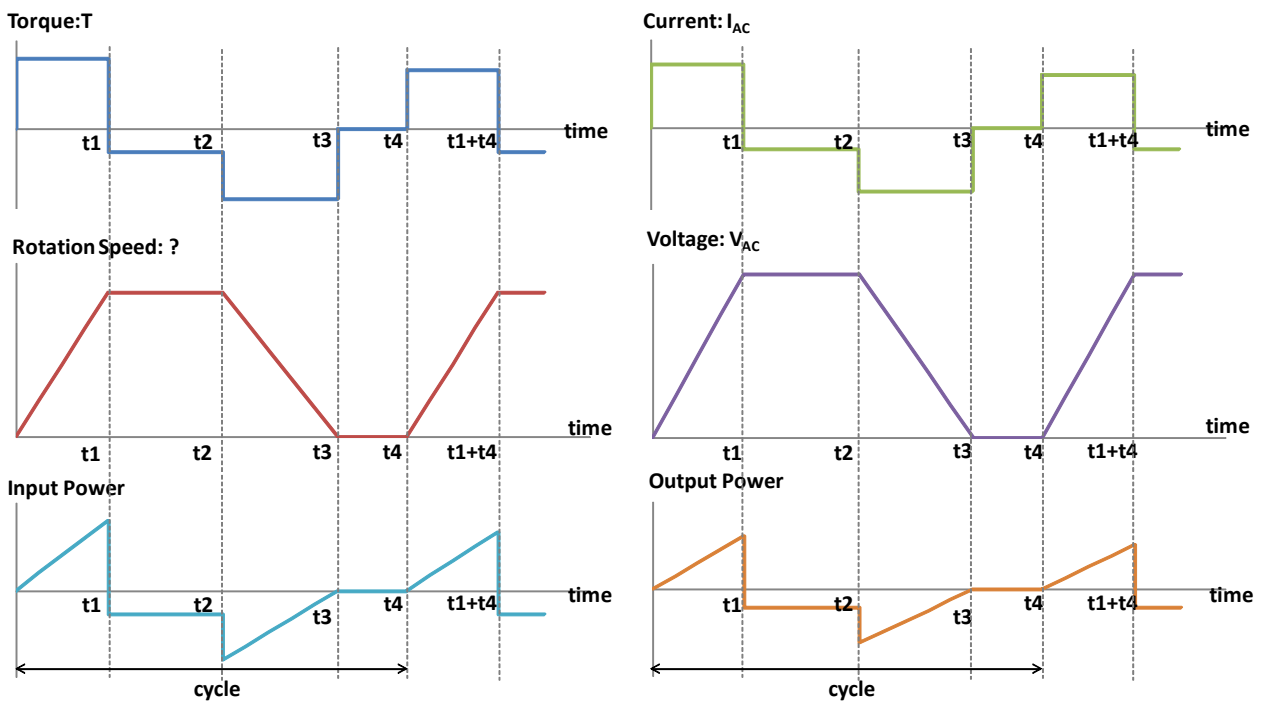

Figure 7.1-2. General cycle of motor : Constant rotation speed with negative torque.

## 7.2 Data Calculation

We only consider the negative power in regenerative mode. Output power in figure 7.2-1 and figure 7.2-2 shows the braking power from figure 7.1-2 and figure 7.2-2. Maximum braking power  $P_{MAX}$  means the maximum power in regenerative mode. Duty cycle defines as the ratio of operating time in maximum braking power to total time.

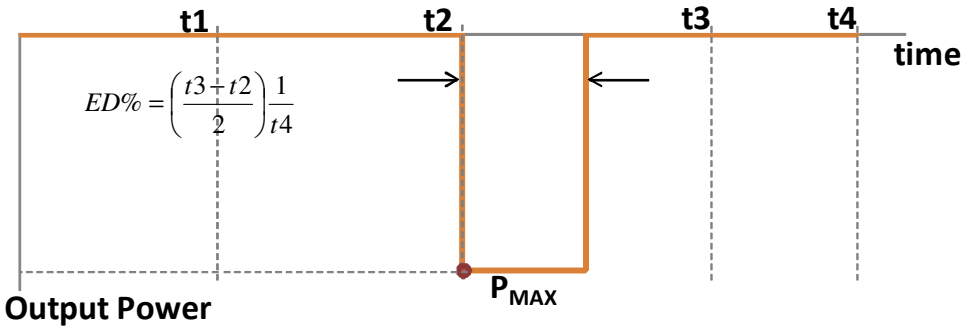
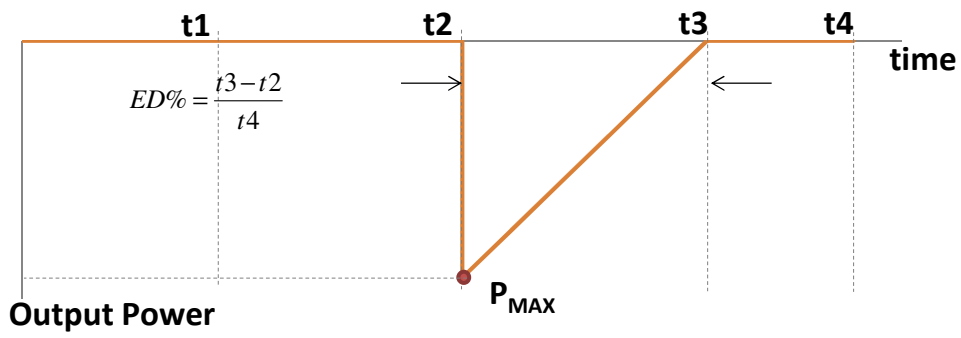

Figure 7.2-1 Original and equivalent model in condition 1.

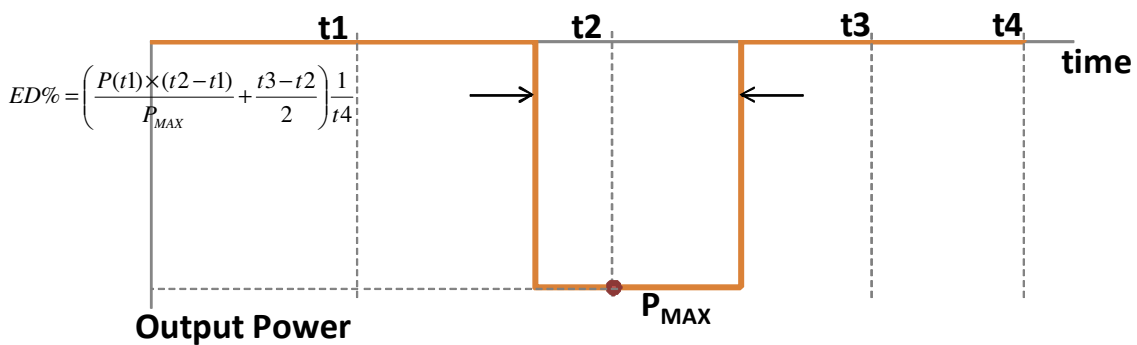
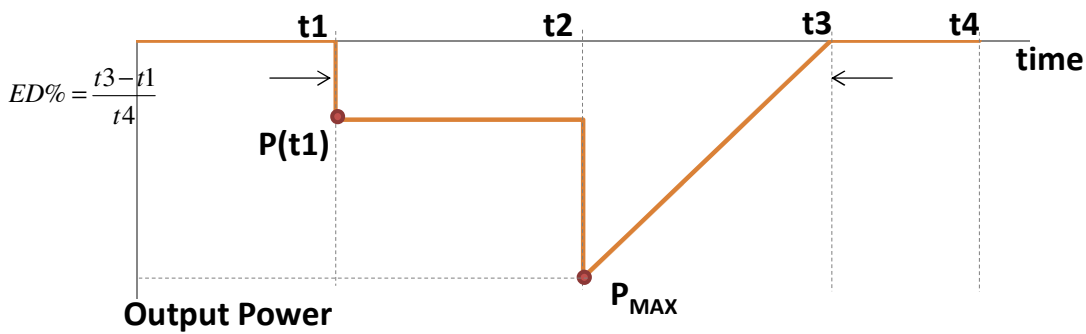

Figure 7.2-2 Original and equivalent model in condition 2.



### Step 1: Calculate maximum braking power $P_{MAX}$

$$P_{MAX} = T ( t_2 ) \times \omega ( t_2 ) \times \eta_{me} \times \eta_{mo}$$

or 
$$P_{MAX} = \sqrt{3} \times V_{AC} ( t_2 ) \times I_{AC} ( t_2 ) \times \cos ( \theta_{t2} )$$

$T ( t_2 )$  : Braking torque at time  $t_2$  , unit is Nm

$\omega ( t_2 )$  : Rotation speed at time  $t_2$ , unit is rad/s

$\eta_{me}$  : Motor efficiency

$\eta_{mo}$  : Mechanical efficiency

$V_{AC} ( t_2 )$  : Output AC voltage at time  $t_2$ , unit is voltage

$I_{AC} ( t_2 )$  : Output AC current at time  $t_2$ , unit is Amp.

$\cos ( \theta_{t2} )$  : Output power factor at time  $t_2$

Maximum braking power is calculated by braking torque, rotation speed, mechanical efficiency, and motor efficiency. Maximum braking power is also calculated by output AC voltage and current when the torque or the efficiency of mechanical, motor is not determined.

### Step 2: Calculate duty cycle ED%, average braking power $P_{ave}$

For condition 1 : 
$$ED_M\% = \frac{t_3 - t_2}{2} \times \frac{1}{t_4} \times 100\%$$

$$P_{ave} = P_{MAX} \times ED_M\%$$

$$\text{For condition 2 : ED}_M\% = \left( \frac{t3 - t2}{2} + \frac{P(t1) \times (t2 - t1)}{P_{MAX}} \right) \times \frac{1}{t4} \times 100\%$$

$$P_{ave} = P_{MAX} \times ED_M\%$$

$$P(t1) = T(t1) \times \omega(t1) \times \eta_{me} \times \eta_{mo}$$

$$\text{Or} \quad = \sqrt{3} \times V_{AC}(t1) \times I_{AC}(t1) \times \cos(\theta_{t1})$$

$V_{DC}$  : DC bus voltage, equal to 380V at 230V drive, 760V at 480V drive

$P(t1)$  : Braking power with constant rotation speed at time  $t1$ , unit is Watt

$V_{AC}(t1)$  : Output AC voltage at time  $t1$ , unit is voltage

$I_{AC}(t1)$  : Output AC current at time  $t1$ , unit is Amp

$\cos(\theta_{t1})$  : Output power factor at time  $t1$

### 7.3 Select Brake Resistor:

**Step 1: Calculate the Maximum Braking Resistance  $R_{MAX}$**

$$R_{MAX} = \frac{V_{DC}^2}{P_{MAX}}$$

**Step 2: Choose the brake resistor satisfied the following condition.**

Rated Power of Brake Resistance :  $P_r > P_{ave}$

Allowed maximum Power of Brake Resistance :  $P_{Mr} > P_{MAX}$

Resistance of the Brake Resistance :  $R_b < R_{MAX}$

Allowed maximum power of brake resistance  $P_{Mr}$  is function of duty cycle and working time, as shown in figure 7.3. Allowed maximum power decreases as the duty cycle and working time increase. Rated power of brake resistor means operation in 100%ED, and must be greater than average power of brake resistor  $P_{ave}$ .

Any operating condition means a point in figure 7.3, which can be defined by maximum braking power and working time. Brake resistor is available when the operating condition is below the corresponding duty cycle curve. If operating duty cycle is not shown in brake resistor curve, we can interpolate the duty cycle and duty time between 2 nearest curves to define the curve.

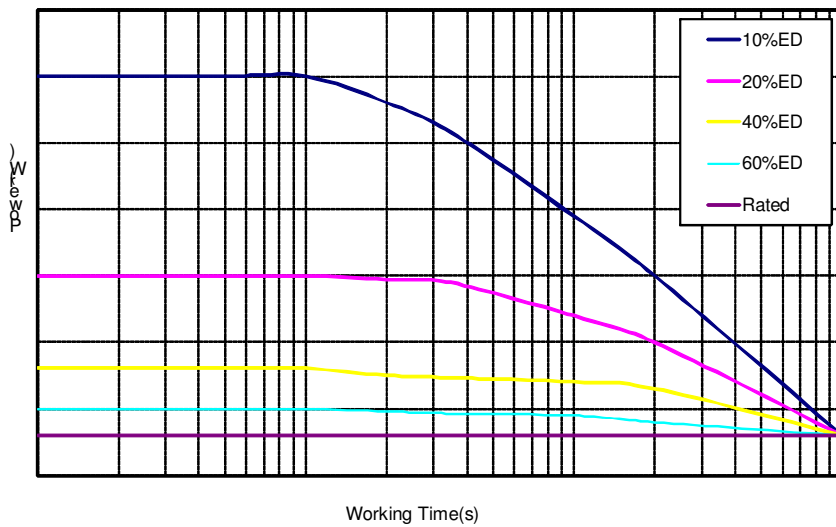

Figure 7.3 Brake resistor working curve

## 7.4 Select Brake Module:

### 7.4.1 Built-in Brake module

**Step 1: Calculate the maximum braking current  $I_{MAX}$ :**

$$I_{MAX} = \frac{V_{DC}}{R_b}$$

**Step 2: Choose the brake module satisfied the following condition.**

$$\text{Allowed Current of Brake Module : } I_{IM} > I_{MAX}$$

Allowed duty current of built-in brake module is only a fixed value, and maximum braking current must be less than the value. When the maximum braking current is larger than the allowed current inside brake module, the rated power of drive should be chosen larger one until the built-in brake module can bear the maximum braking current.

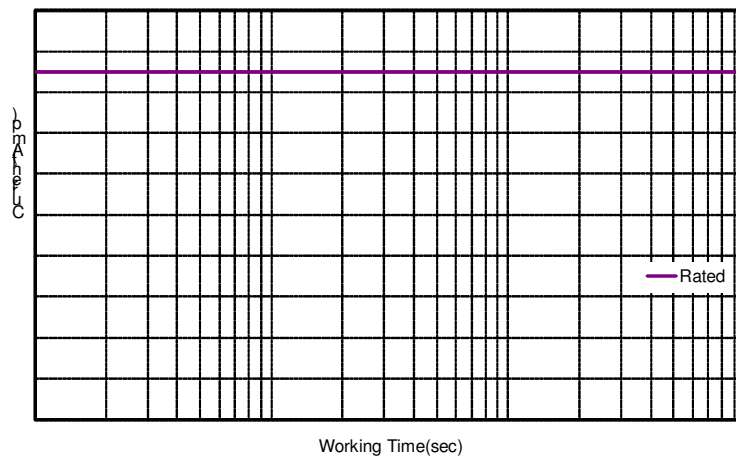

Figure 7.4.1 Built-in brake module working curve

## 7.4.2 External Brake module Drive

**Step 1: Calculate the maximum braking current  $I_{MAX}$ , and average braking current  $I_{ave}$**

$$I_{MAX} = \frac{V_{DC}}{R_b}$$

$$I_{ave} = \frac{V_{DC}}{R_b} \times ED\%$$

**Step 2: Choose the brake module satisfied the following condition.**

Continuous current of Brake module :  $I_{ec} > P_{ave}$

Allowed Maximum Current of Brake Module :  $I_{eM} > I_{MAX}$

Allowed maximum current of brake module  $I_{eM}$  is function of duty cycle and working time, as shown in figure 7.4.2. Allowed maximum current decreases as the duty cycle and working time increase. Rated current of brake module means operation in 100%ED, and must be greater than average current of brake module  $I_{ave}$ .

Any operating condition mean a point in figure 7.4.2, which can be defined by maximum braking current and working time. Brake module is available when the operating condition is below the corresponding duty cycle. If operating duty cycle is not shown in brake module curve, we can interpolate the duty cycle and duty time between 2 nearest curves to define the curve.

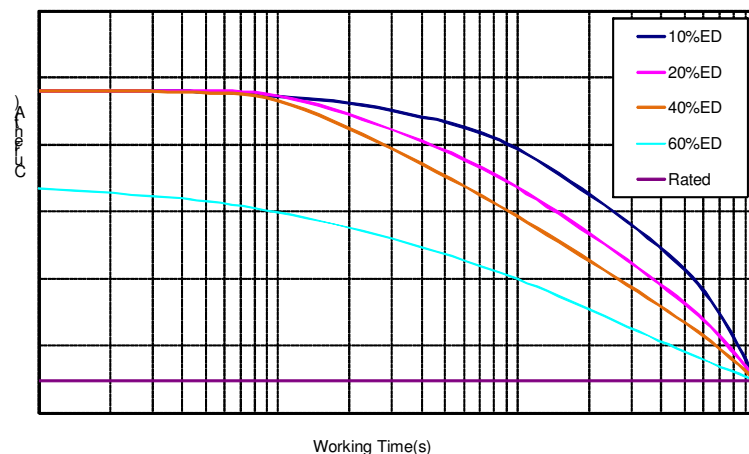

Figure 7.4.2 External brake module working curve

## 7.5 Example Calculation:

A 20 HP, 230 Volt motor and drive is accelerating and decelerating as depicted in figure 1. The period is 50 seconds, and it means the  $t_4$  is equal to 50 seconds. The rated rotation speed of motor is 1500 rpm, and decrease to 0 rpm in 10 seconds. Decelerating torque is equal to 40 N-m. Select the acceptable External Brake Module and Brake Resistor. Mechanical efficiency is 80%, and motor efficiency is 90%.

### Data Calculation:

$$T ( t_2 ) = 40\text{Nm}$$

$$\omega ( t_2 ) : \text{Rotation speed } 1500 \text{ rpm} = 157.08 \text{ rad/s.}$$

$$\eta_{me} = 0.8$$

$$\eta_{mo} = 0.9$$

$$V_{DC} = 380$$

$$\begin{aligned} \text{Max braking power } P_{MAX} &= T ( t_2 ) \times \omega ( t_2 ) \times \eta_{me} \times \eta_{mo} \\ &= 40 \times 157.08 \times 0.8 \times 0.9 = 4523.9 ( W ) \end{aligned}$$

$$\text{Duty cycle ED\%} = \frac{t_3-t_2}{2} \times \frac{1}{t_4} \times 100\% = \frac{10}{50} \times \frac{1}{2} \times 100\% = 10\%$$

$$\text{Average braking power } P_{ave} = P_{MAX} \times \text{ED\%} = 4523.9 \times 10\% = 452.4 ( W )$$

Select Brake Resistor:

$$R_{MAX} = \frac{V_{DC}^2}{P_{MAX}} = \frac{380^2}{4523.9} = 31.92 \text{ ( ohm )}$$

$$R_b = 30 \text{ ( ohm )}$$

For a common resistance specification is less than  $R_{MAX}$  and approach the value is 30 ohm. Select a brake resistor whose rated power is greater than  $P_{ave}= 452.4W$ , such as figure 7.5-1, the rated operating power is 600W. Then we depict the braking condition in the figure.  $P_{MAX}$  is below the 10% duty cycle curve, and the brake resistor is available.

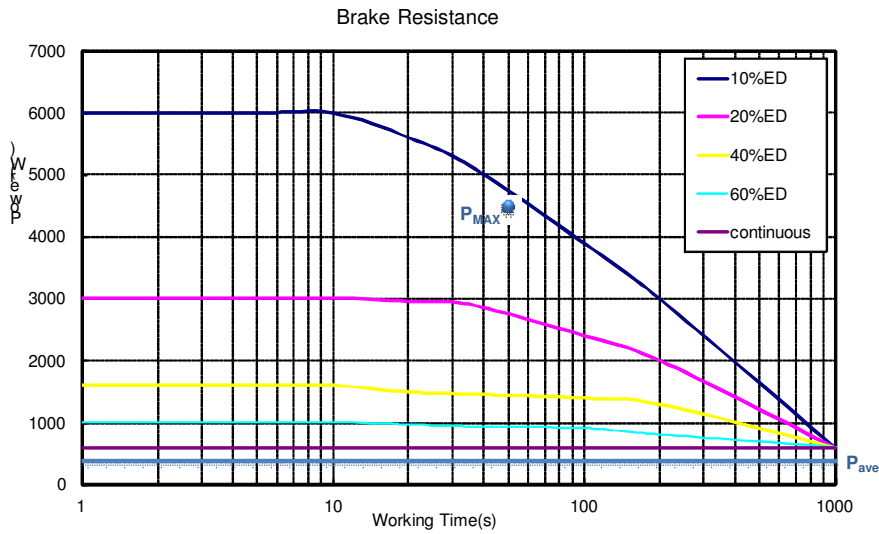

Figure 7.5-1 600W Power curve of brake resistor

Select External Brake Module:

$$\text{Maximum braking current } I_{MAX} = \frac{V_{DC}}{R_b} = \frac{380}{30} = 12.67 \text{ ( A )}$$

$$\text{Average braking current } I_{ave} = \frac{V_{DC}}{R_b} \times \text{ED\%} = \frac{380}{30} \times 10\% = 1.27 \text{ ( A )}$$

Select a brake module whose rated current is greater than  $I_{ave}= 1.27$  Amp, such as figure 7.5-2, the Rated operating power is 12.2Amp. Then we depict the maximum braking current condition in the figure.  $I_{MAX}$  is below the 10% duty cycle curve, and the brake module is available.

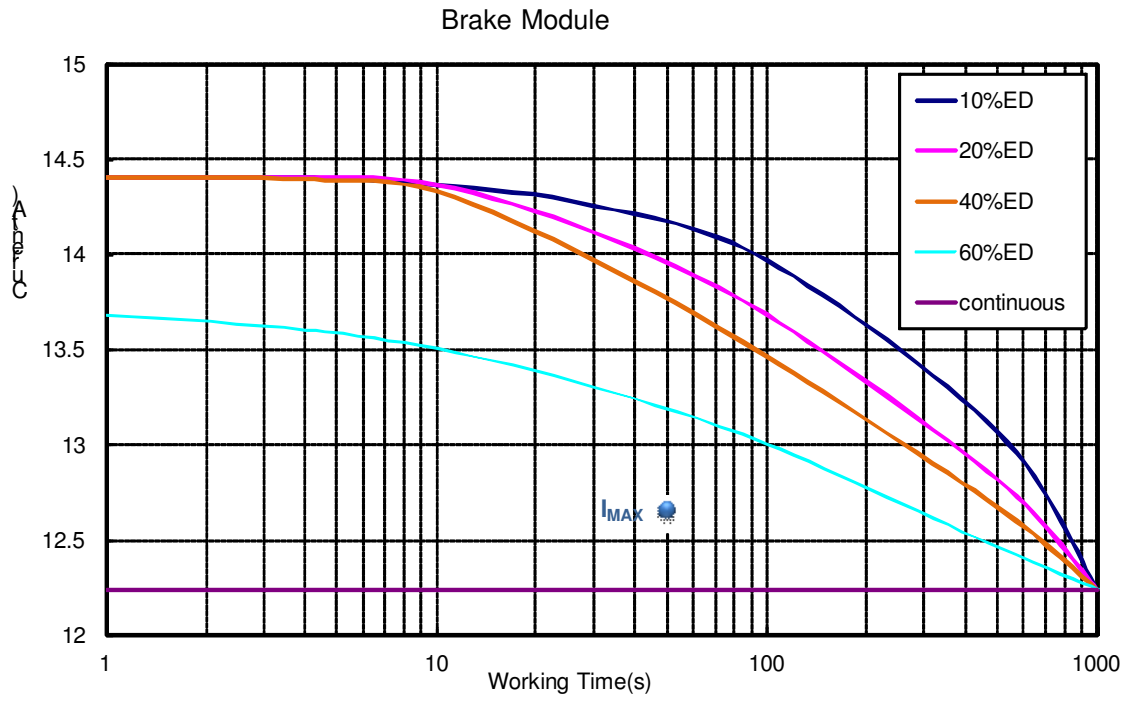

Figure 7.5-2 12.2 Amp Current curve of Brake module



## 7.6 Braking capability

### 7.6.1 Braking capability of C2000

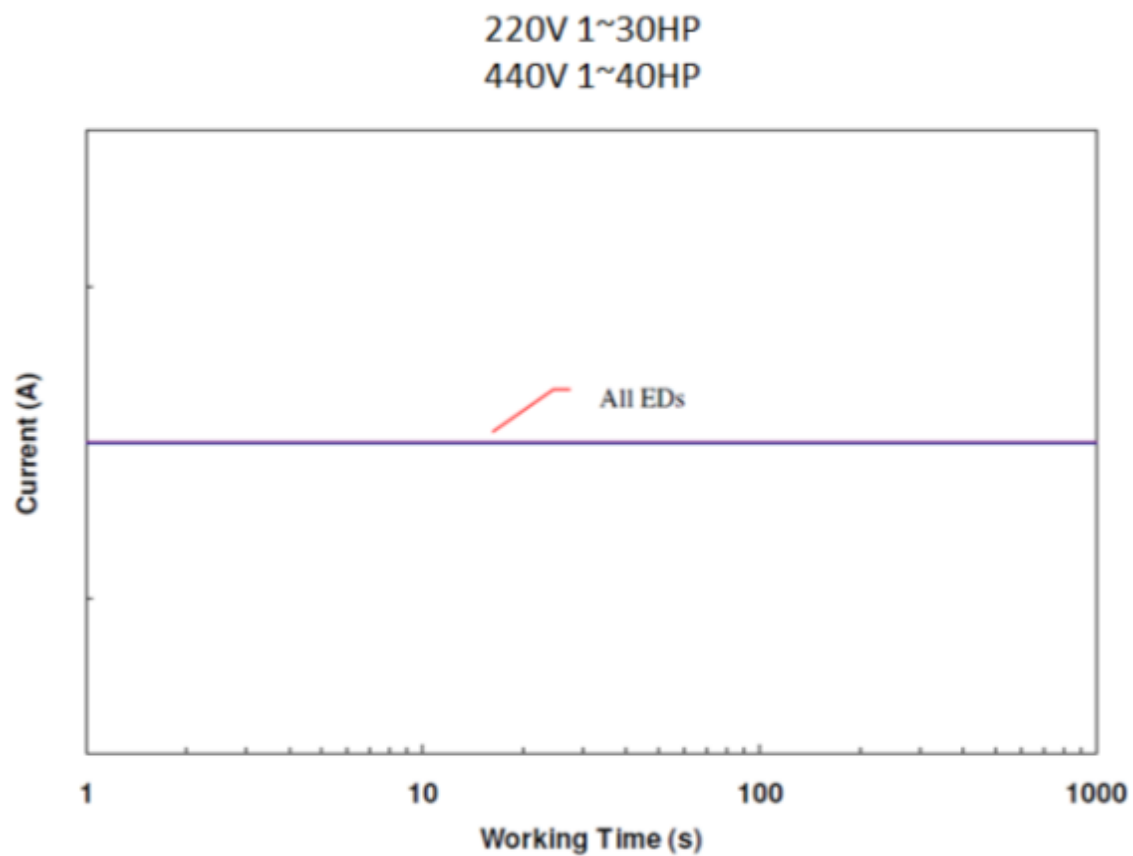

Figure 7.6.1-1

Model	HP	kW	Max. brake current limitation (A)
VFD007C23A	1	0.7	6
VFD015C23A	2	1.5	8
VFD022C23A	3	2.2	10
VFD037C23A	5	3.7	20
VFD055C23A	7.5	5.5	26
VFD075C23A	10	7.5	26
VFD110C23A	15	11	29
VFD150C23A	20	15	46
VFD185C23A	25	18	46
VFD220C23A	30	22	66
VFD300C23A	40	30	80
VFD370C23A	50	37	120
VFD450C23A	60	45	120
VFD550C23A	75	55	180
VFD750C23A	100	75	240
VFD900C23A	125	90	240

Model	HP	kW	Max. brake current limitation (A)
VFD007C43A	1	0.7	4
VFD015C43A	2	1.5	6
VFD022C43A	3	2.2	7
VFD037C43A	5	3.7	9
VFD040C43A	5	4	14
VFD055C43A	7.5	5.5	14
VFD075C43A	10	7.5	16
VFD110C43A	15	11	18
VFD150C43A	20	15	29
VFD185C43A	25	18	33
VFD220C43A	30	22	33
VFD300C43A	40	30	54
VFD370C43A	50	37	60
VFD450C43A	60	45	60
VFD550C43A	75	55	80
VFD750C43A	100	75	120
VFD900C43A	125	90	120
VFD1100C43A	150	110	126

Model	HP	kW	Max. brake current limitation (A)
VFD1320C43A	175	132	190
VFD1600C43A	215	160	190
VFD1850C43A	250	185	225
VFD2200C43A	300	220	252
VFD2800C43A	375	280	380
VFD3150C43A	425	315	380
VFD3550C43A	475	355	450

Figure 7.6.1-1 Maximum brake current limitation of each C2000 model

7.6.2 Braking capability of CH2000

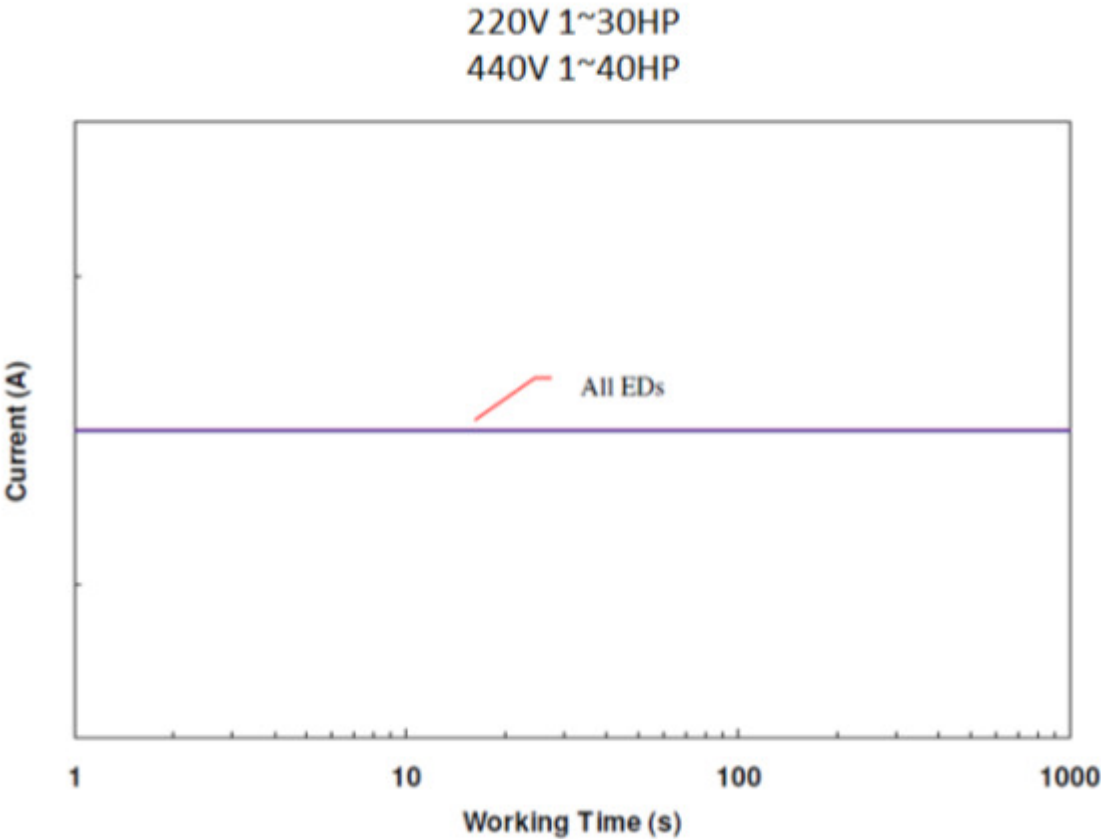

Figure 7.6.2-1

Model	HP	kW	Max. brake current limitation (A)
VFD007CH23A	1	0.7	6
VFD015CH23A	2	1.5	8
VFD022CH23A	3	2.2	10
VFD037CH23A	5	3.7	20
VFD055CH23A	7.5	5.5	26
VFD075CH23A	10	7.5	26
VFD110CH23A	15	11	28
VFD150CH23A	20	15	46
VFD185CH23A	25	18	46
VFD220CH23A	30	22	66
VFD300CH23A	40	30	80
VFD370CH23A	50	37	120
VFD450CH23A	60	45	120
VFD550CH23A	75	55	180
VFD750CH23A	100	75	240

Model	HP	kW	Max. brake current limitation (A)
VFD007CH43A	1	0.7	4
VFD015CH43A	2	1.5	6
VFD022CH43A	3	2.2	7
VFD037CH43A	5	3.7	9
VFD040CH43A	5.5	4	14
VFD055CH43A	7.5	5.5	14
VFD075CH43A	10	7.5	16
VFD110CH43A	15	11	18
VFD150CH43A	20	15	29
VFD185CH43A	25	18	33
VFD220CH43A	30	22	33
VFD300CH43A	40	30	54
VFD370CH43A	50	37	60
VFD450CH43A	60	45	60
VFD550CH43A	75	55	80
VFD750CH43A	100	75	120
VFD900CH43A	125	90	120
VFD1100CH43A	150	110	126

Model	HP	kW	Max. brake current limitation (A)
VFD1320CH43A	175	132	190
VFD1600CH43A	215	160	190
VFD1850CH43A	250	185	225
VFD2200CH43A	300	220	225
VFD2800CH43A	375	280	380

Figure 7.6.2-1 Maximum brake current limitation of each CH2000 model



7.6.3 Braking capability of CP2000

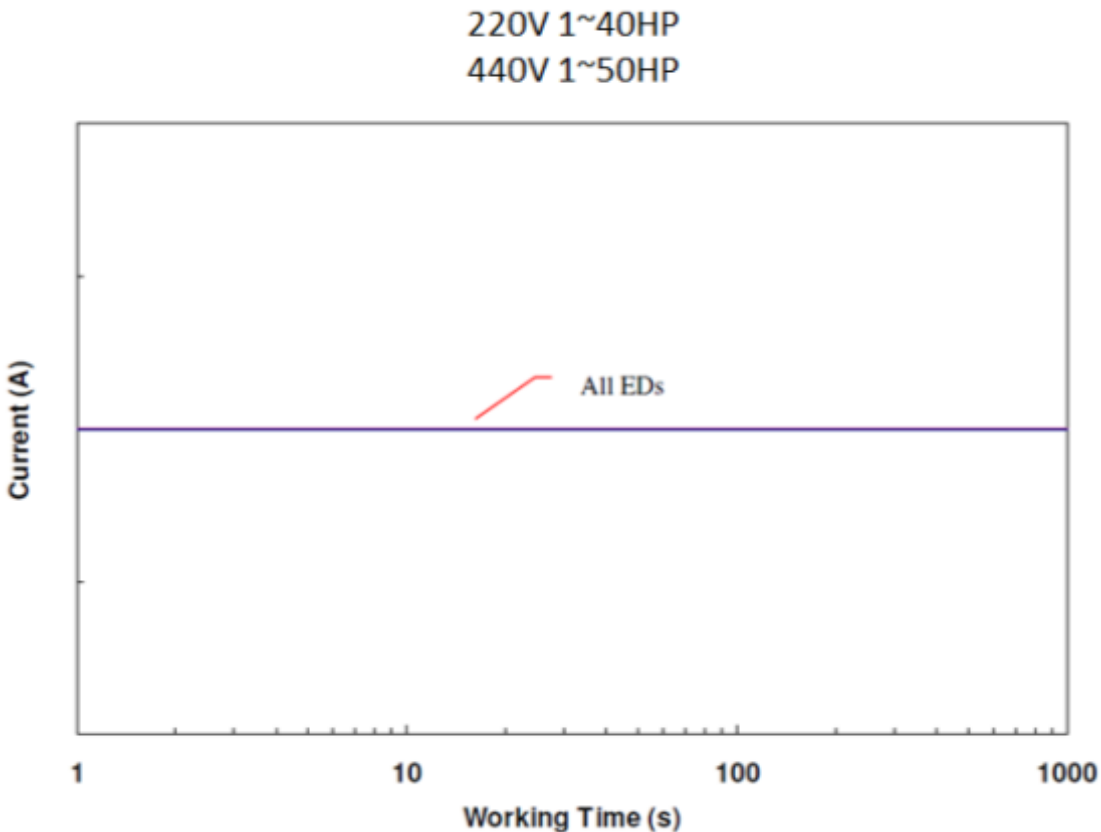

Figure 7.6.3-1

Model	HP	kW	Max. brake current limitation (A)
VFD007CP23A	1	0.7	6
VFD015CP23A	2	1.5	6
VFD022CP23A	3	2.2	8
VFD037CP23A	5	3.7	10
VFD055CP23A	7.5	5.5	20
VFD075CP23A	10	7.5	26
VFD110CP23A	15	11	26
VFD150CP23A	20	15	28
VFD185CP23A	25	18	46
VFD220CP23A	30	22	46
VFD300CP23A	40	30	66
VFD370CP23A	50	37	80
VFD450CP23A	60	45	120
VFD550CP23A	75	55	120
VFD750CP23A	100	75	180
VFD900CP23A	125	90	240

Model	HP	kW	Max. brake current limitation (A)
VFD007CP43A	1	0.7	4
VFD015CP43A	2	1.5	4
VFD022CP43A	3	2.2	6
VFD037CP43A	5	3.7	7
VFD040CP43A	5	4	9
VFD055CP43A	7.5	5.5	14
VFD075CP43A	10	7.5	14
VFD110CP43A	15	11	16
VFD150CP43A	20	15	18
VFD185CP43A	25	18	29
VFD220CP43A	30	22	33
VFD300CP43A	40	30	33
VFD370CP43A	50	37	54
VFD450CP43A	60	45	60
VFD550CP43A	75	55	60
VFD750CP43A	100	75	80
VFD900CP43A	125	90	120
VFD1100CP43A	150	110	120

Model	HP	kW	Max. brake current limitation (A)
VFD1320CP43A	175	132	126
VFD1600CP43A	215	160	190
VFD1850CP43A	250	185	190
VFD2200CP43A	300	220	225
VFD2800CP43A	375	280	252
VFD3150CP43A	425	315	380
VFD3550CP43A	475	355	380
VFD4000CP43A	536	400	450

Figure 7.6.3-1 Maximum brake current limitation of each CP2000 model

## 7.6.4 Brake unit

- VFDB :
- VFDB2015

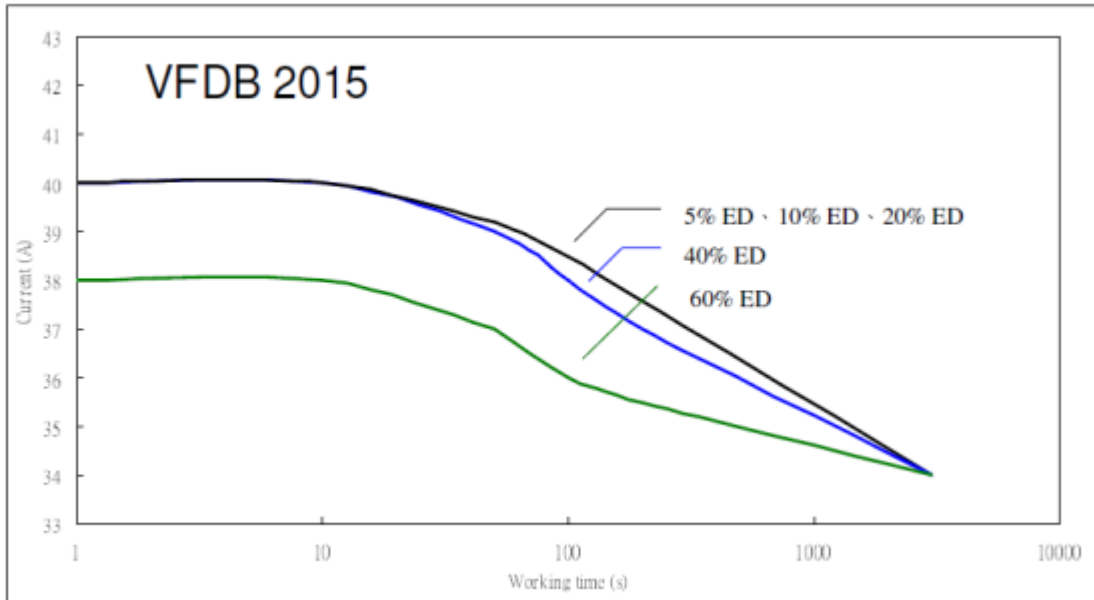

- VFDB2022

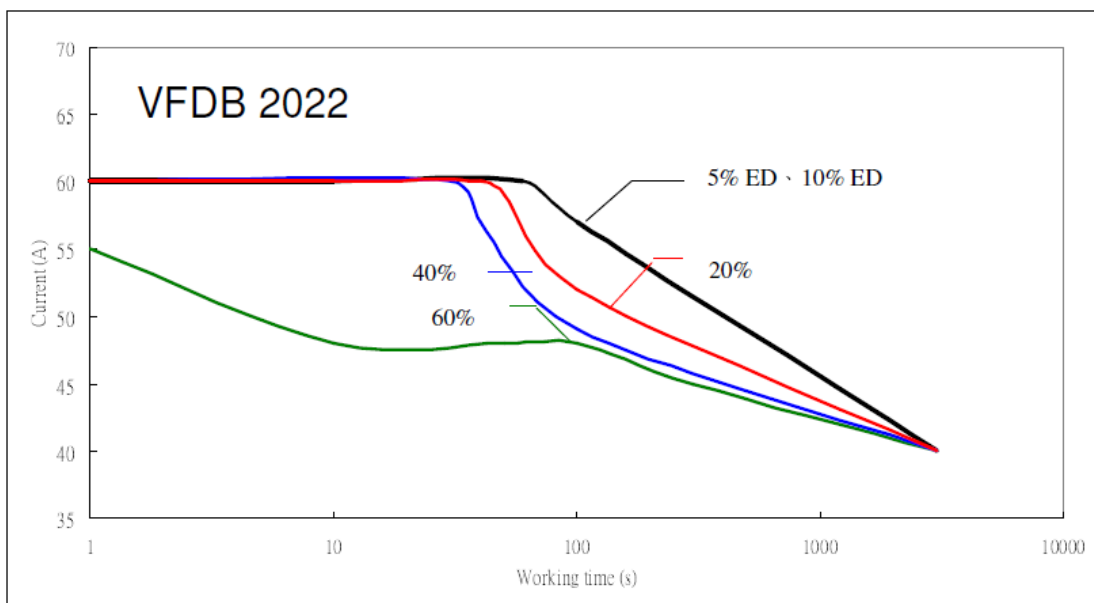

➤ VFDB4030

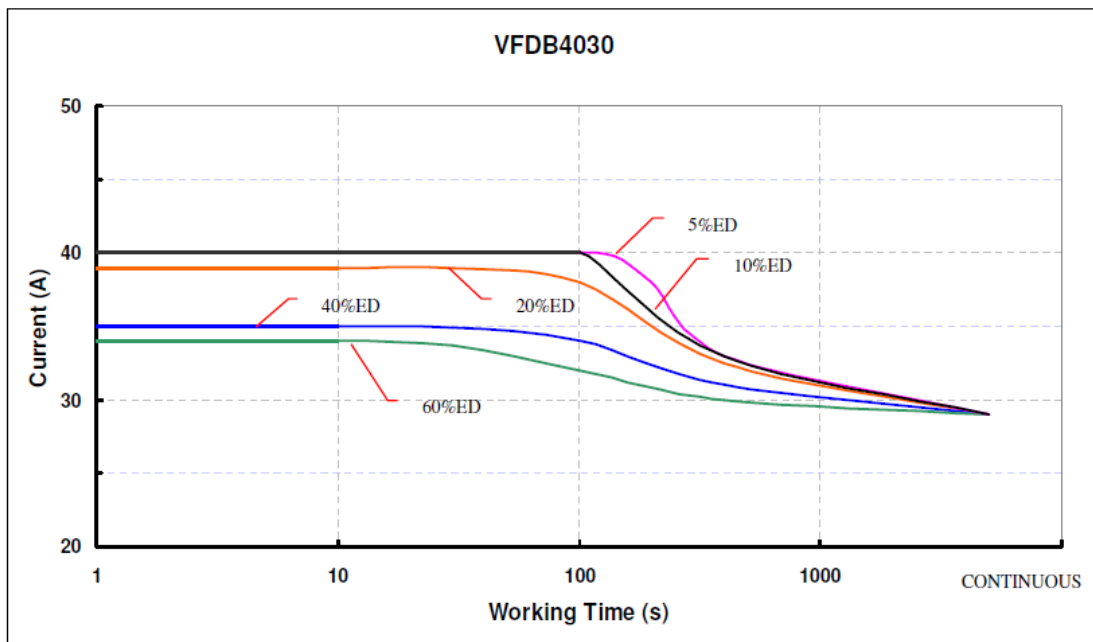

➤ VFDB4045

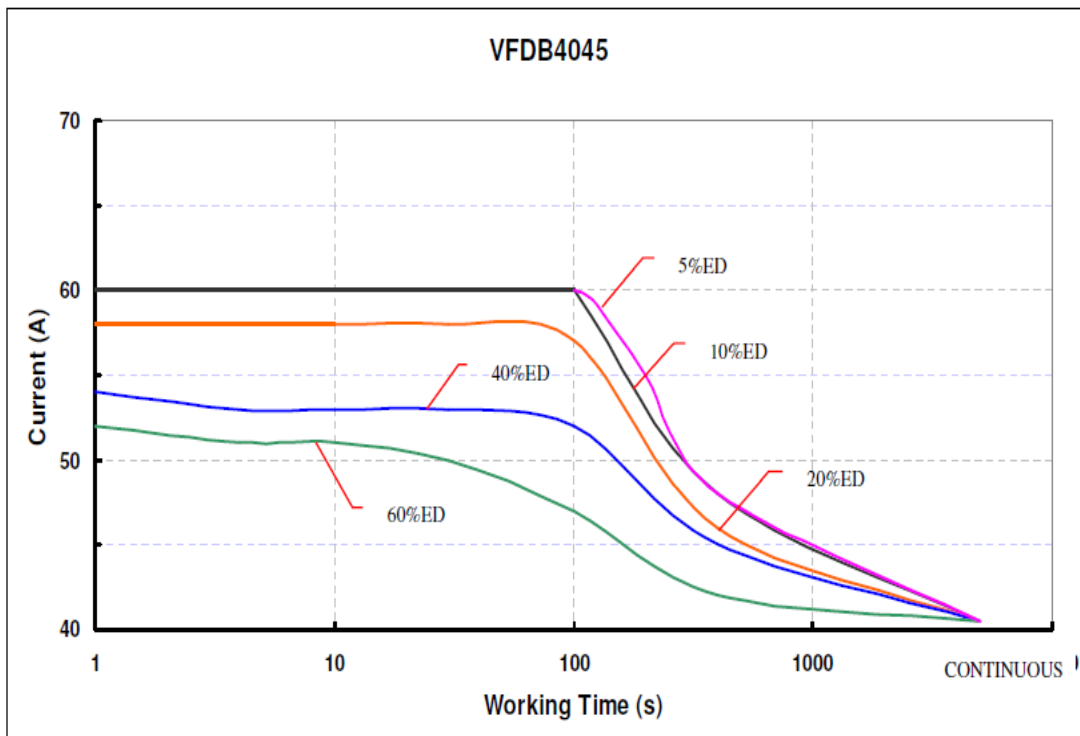

➤ VFDB4110

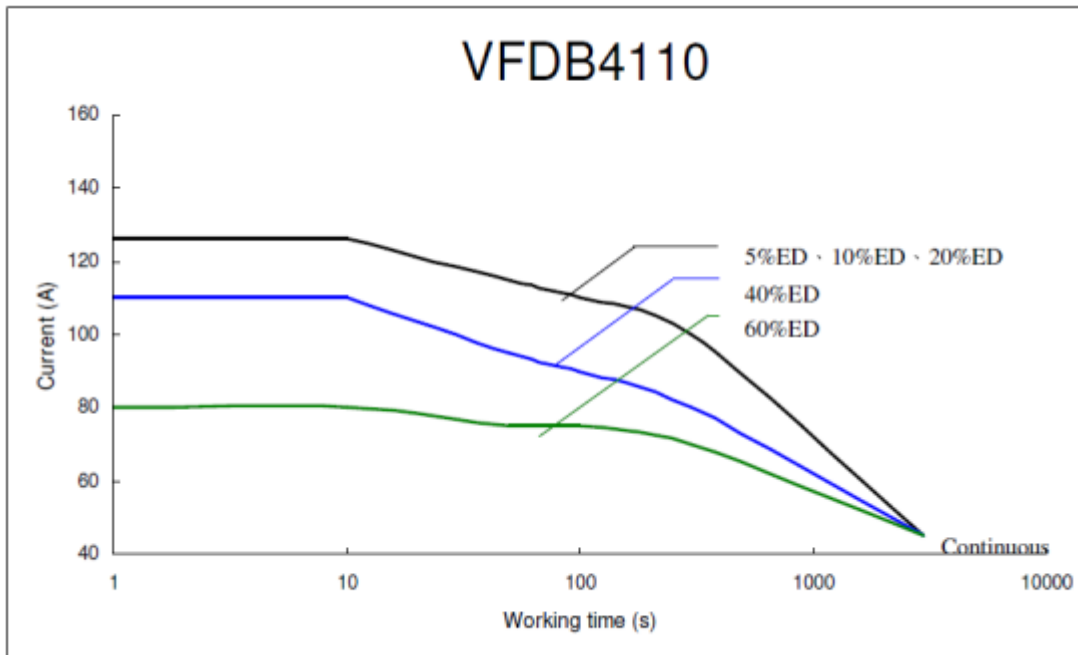

➤ VFDB4160

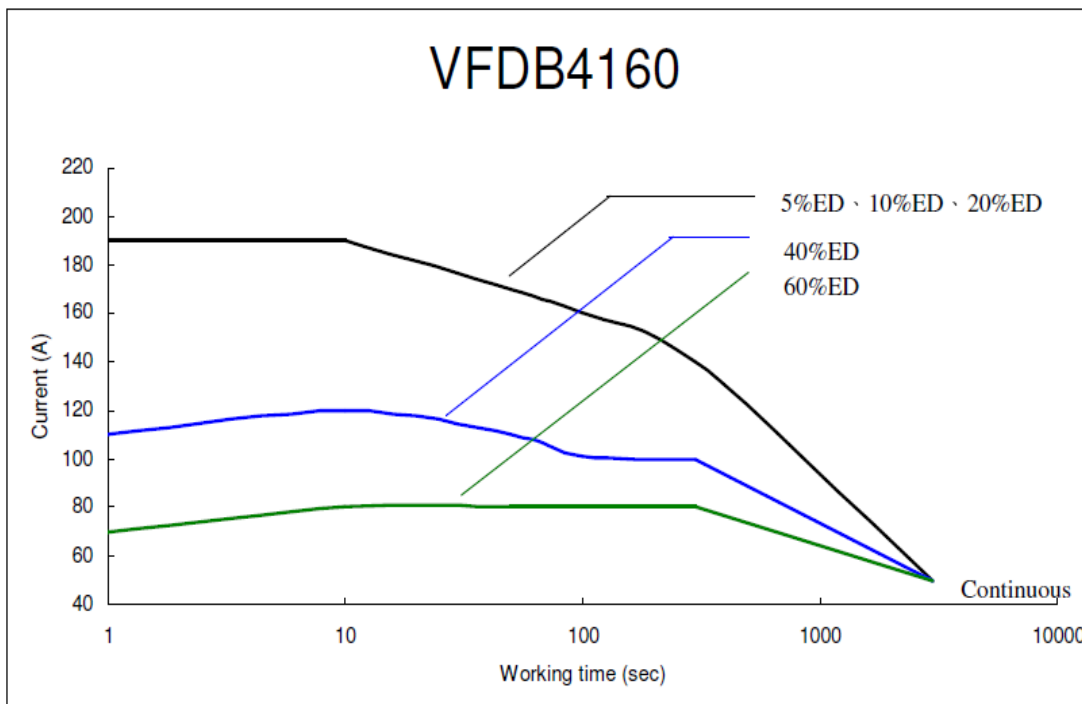

➤ VFDB4185

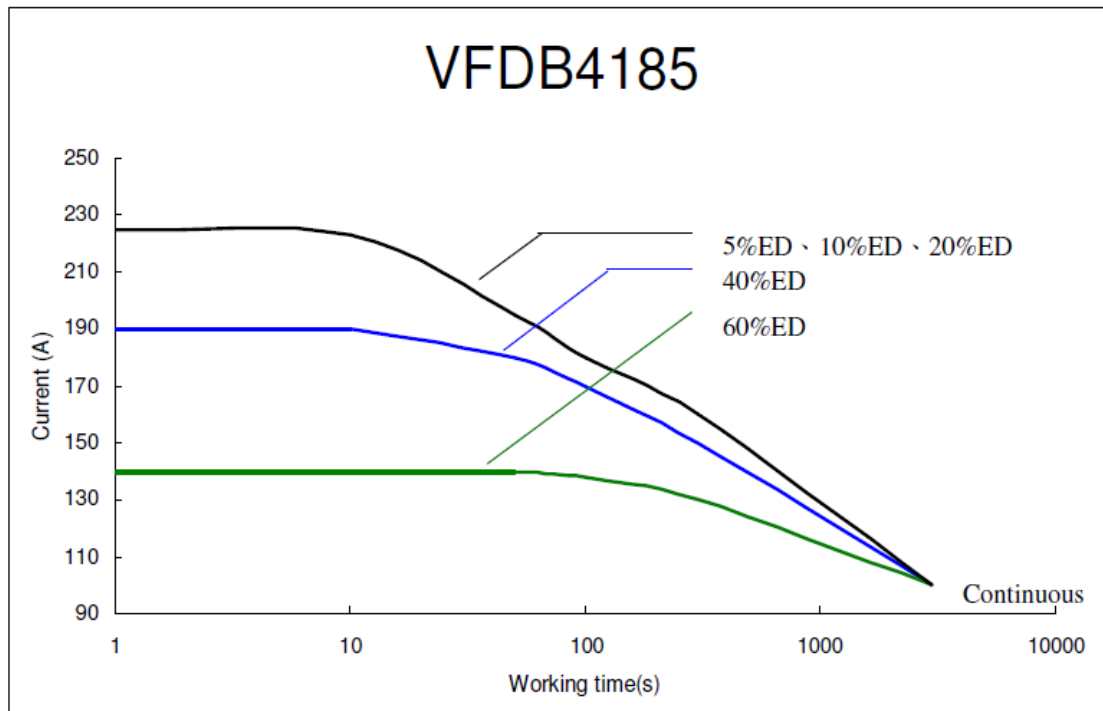



## 8. Estimation of reliability and key component life

In order to enhance the product quality and client requirements, the “estimation of reliability and the service life of key components” is a necessary process for product development. This is to ensure that the lifespan of the components is taken into consideration during the development phase. The following information is divided into three parts.

- Based on the calculation of reliability estimation manual (FIDES), under a given condition (such as ambient temperature, load and duty cycle), calculate the MTBF (Mean Time to Failure) by inputting the response temperature of each component into the reliability standard FIDES (FIDES guide 2009 - Reliability Methodology for Electronic Systems).
- Key component life: under a given condition (such as ambient temperature, load and work time per day), measure the response temperature, and then calculate the key component life via the reliability datasheet.
- Field return: obtain the reliability MTBF of the products through customer feedback of returned products.

## 8.1 Reliability Prediction and Key Component Life of C2000

### 8.1.1 Reliability Prediction Report (by FIDES guide)

#### 1. Product Model Name:

Product	Series
ACMD	C

#### 2. Required:

Reliability Prediction

#### 3. Purpose:

Reliability prediction methodology provides the basis for reliability evaluation and analysis. The purpose of the prediction is to predict the life time of the product in units of failure rate and MTBF.

#### 4. Results:

Conclusion	
MTBF	125,794 hours
Description	The analysis is at 40°C ambient temperature by FIDES guide 2009, Method I under 80% operation stress and 50% duty cycle.

#### 5. Prediction Method:

FIDES guide 2009 - Reliability Methodology for Electronic Systems

Method 1: Use of operational databases (aeronautical and military) on failure mechanisms.

#### 6. Calculation Parameter:

Operation Temperature: 40 °C

Duty Cycle: 50%

Operation Stress: 80%

## 7. Prediction Summary:

Total Failure Rate	<b>7949.50</b>	Failures/10 <sup>9</sup> Hours
MTBF	<b>125,794</b>	Hours

Note:

1. Library components of a near equivalent or similar technology and function were substituted when the parts could not be exactly found in the library.

## 8.1.2 Key Component Life Report

### 1. Product:

Product	Series
ACMD	C

### 2. Required:

Key Components Life evaluation.

### 3. Purpose:

Provide the inverter under standard operating conditions, the average life of key components.

### 4. Results:

series	Output power	key components life (or suggest time for replacement)			
		power module	cooling fan	DC bus Capacitor	Al capacitor on PCB
C2000	230V, 0.7~22kW 460V, 0.7~30kW	10 year	10 year	5~7 year	10 year
	230V, 30~90kW 460V, 37~355kW	10 year	10 year	10 year	10 year

Above tables calculated base on the following conditions:

series	type	average conditions		
		ambient temperature	operate time per day	loading
C2000	open type	40degC	12hr	80%
	type 1	30degC	12hr	80%

Note:

The real lifetime shall depends on the operate conditions (or profile.)  
If there's non-replace part or could not repair, it should replace the entire inventor machine

### 8.1.3 MTBF Prediction Report (based on Field Data)

#### 1. Product :

Product	Series
ACMD	C

#### 2. Required:

Reliability Prediction

#### 3. Purpose:

Reliability prediction methodology provides the basis for reliability evaluation and analysis. The purpose of the prediction is to predict the life time of the product in units of failure rate and MTBF.

#### 4. Results:

Conclusion	
MTBF <sub>L</sub>	$\geq 251,779$ hours
Description	Total Units in Study: 7619 Total Working Hours: 23,433,775 Total Failures (from field RMA data): 77

#### Note:

1. MTBF<sub>L</sub> : Mean Time Between Failure lower limit.
2. The MTBF<sub>L</sub> is calculated from the chi-squared distribution to estimate the true MTBF: Chi-square factor for 77 failures @ 95% confidence = 186.145
3. Units operating in Industry environments, 12 hours per day, 5 days per week.
4. Exponential Failure Distribution.

5. Prediction Method:

Reliability Estimates based on Field Data:

$$MTBF \geq \frac{2T}{\chi^2(\alpha, v = 2n + 2)}$$

Where:

T = total working hours

n = number of failures

$\chi^2$  = chi-squared function

v = degrees of freedom for the lower confidence limit

$\alpha$  = 1- confidence level

## 8.2 Reliability Prediction and Key Component Life of CH2000

### 8.2.1 Reliability Prediction Report (by FIDES guide)

#### 1. Product Model Name:

Product	Series
ACMD	CH

#### 2. Required:

Reliability Prediction

#### 3. Purpose:

Reliability prediction methodology provides the basis for reliability evaluation and analysis. The purpose of the prediction is to predict the life time of the product in units of failure rate and MTBF.

#### 4. Results:

Conclusion	
MTBF	111,041 hours
Description	The analysis is at 40°C ambient temperature by FIDES guide 2009, Method I under 80% operation stress and 50% duty cycle.

#### 5. Prediction Method:

FIDES guide 2009 - Reliability Methodology for Electronic Systems

#### 6. Calculation Parameter:

Operation Temperature: 40 °C

Duty Cycle: 50%

Operation Stress: 80%

## 7. Prediction Summary:

Total Failure Rate	<b>9005.66</b>	Failures/10 <sup>9</sup> Hours
MTBF	<b>111,041</b>	Hours

Note:

1. Library components of a near equivalent or similar technology and function were substituted when the parts could not be exactly found in the library.



## 8.2.2 Key Component Life Report

### 1. Product:

Product	Series
ACMD	CH

### 2. Required:

Key Components Life evaluation.

### 3. Purpose:

Provide the inverter under standard operating conditions, the average life of key components.

### 4. Results:

series	Output power	key components life (or suggest time for replacement)			
		power module	cooling fan	DC bus Capacitor	Al capacitor on PCB
CH2000	230V, 0.7~18.5kW 460V, 0.7~30kW	Over 10 years	Over 10 years	6 years	Over 10 years
	230V, 22~75kW 460V, 37~132kW	Over 10 years	Over 10 years	8 years	Over 10 years
	460V, 160~280kW	Over 10 years	6 years	8 years	Over 10 years

Above tables calculated based on the following conditions:

series	Output power	conditions		
		ambient temperature	operate time per day	Loading
CH2000	230V, 0.7~18.5kW 460V, 0.7~30kW	40degC	12hr	80%
	230V, 22~75kW 460V, 37~132kW			
	460V, 160~280kW			

Note:

The real lifetime shall depends on the operate conditions (or profile.)

If there's non-replace part or could not repair, it should replace the entire inventor machine

## 8.3 Reliability Prediction and Key Component Life of CP2000

### 8.3.1 Reliability Prediction Report (by FIDES guide)

#### 1. Product Model Name:

Product	Series
ACMD	CP

#### 2. Required:

Reliability Prediction

#### 3. Purpose:

Reliability prediction methodology provides the basis for reliability evaluation and analysis. The purpose of the prediction is to predict the life time of the product in units of failure rate and MTBF.

#### 4. Results:

Conclusion	
MTBF	124,675 hours
Description	The analysis is at 40°C ambient temperature by FIDES guide 2009, Method I under 80% operation stress and 50% duty cycle.

#### 5. Prediction Method:

FIDES guide 2009 - Reliability Methodology for Electronic Systems

#### 6. Calculation Parameter:

Operation Temperature: 40 °C

Duty Cycle: 50%

Operation Stress: 80%

## 7. Prediction Summary:

Total Failure Rate	<b>8020.89</b>	Failures/10 <sup>9</sup> Hours
MTBF	<b>124,675</b>	Hours

Note:

1. Library components of a near equivalent or similar technology and function were substituted when the parts could not be exactly found in the library.

## 8.3.2 Key Component Life Report

### 1. Product:

Product	Series
ACMD	CP

### 2. Required:

Key Components Life evaluation.

### 3. Purpose:

Provide the inverter under standard operating conditions, the average life of key components.

### 4. Results:

series	Output power	key components life (or suggest time for replacement)			
		power module	cooling fan	DC bus Capacitor	Al capacitor on PCB
CP2000	230V, 0.7~30kW 460V, 0.7~37kW	Over 10 years	Over 10 years	6 years	Over 10 years
	230V, 37~90kW 460V, 45~185kW	Over 10 years	Over 10 years	7 years	Over 10 years
	460V, 220~400kW	Over 10 years	6 years	7 years	Over 10 years

Above tables calculated base on the following conditions:

series	Output power	conditions		
		ambient temperature	operate time per day	Loading
CP2000	230V, 0.7~30kW 460V, 0.7~37kW	40degC	12hr	80%
	230V, 37~90kW 460V, 45~185kW			
	460V, 220~400kW			

Note:

The real lifetime shall depends on the operate conditions (or profile.)

If there's non-replace part or could not repair, it should replace the entire inventor machine

## Appendix A

### A.1 EMC filter size

Model	Length	Width	Height	unit
KMF350A	312	93	190	mm
KMF370A	312	93	190	mm
KMF3100A	312	93	190	mm
MIF3400B	873	420	110	mm
MIF3400	625	420	110	mm
MIF3800	625	420	220	mm
EMF014A23A	234	72	55	mm
EMF021A23A	270	87	70	mm
EMF027A23A	275	109	70	mm
EMF035A23A	310	130	80	mm
EMF056A23A	390	155	80	mm
EMF008A43A	234	72	55	mm
EMF014A43A	270	87	70	mm
EMF018A43A	275	109	70	mm
EMF033A43A	310	130	80	mm
EMF039A43A	390	155	80	mm
B84143D0150R127	479	125	226	mm
B84143D0200R127	542	199	259	mm
B84143B0250S020	360	140	115	mm
B84143B0400S020	360	210	116	mm
B84143B1000S020	420	250	166	mm

Table A.1-1:EMC filter size

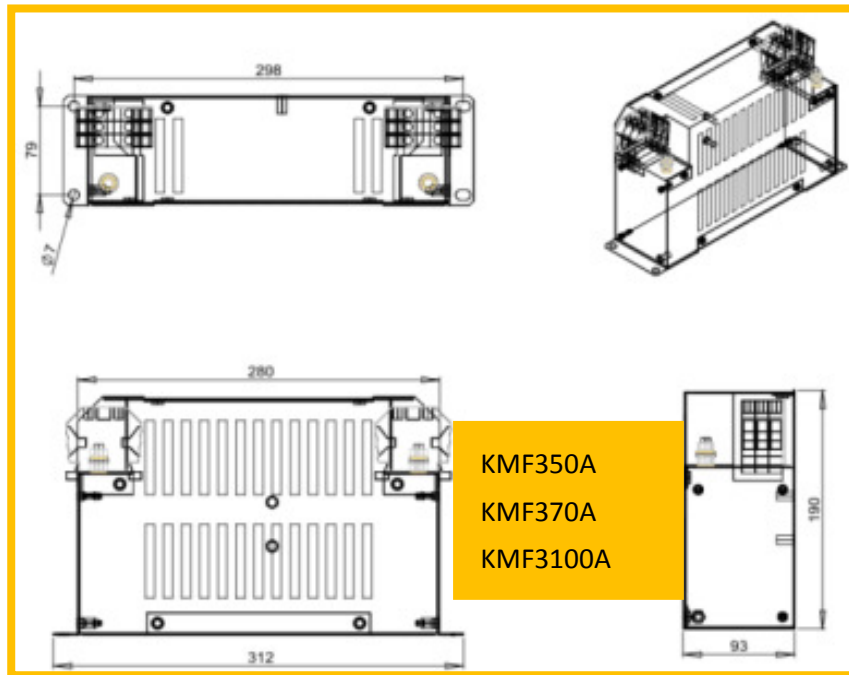

Figure A.1-1: EMI filter of KMF series

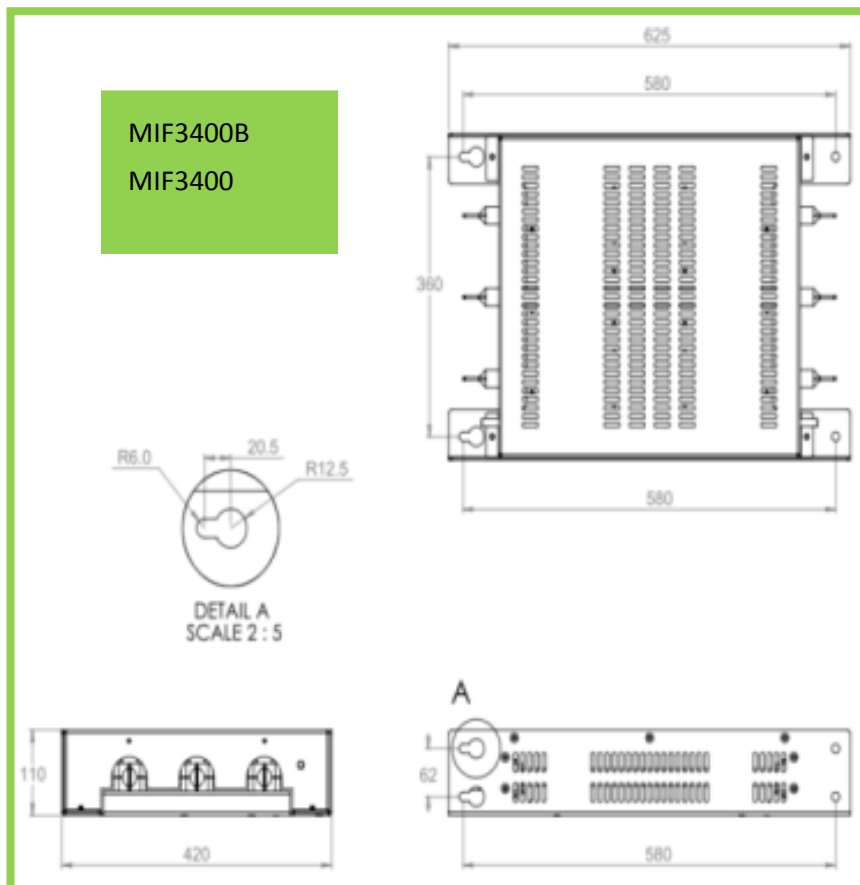

Figure A.1-2: EMI filter of MIF series

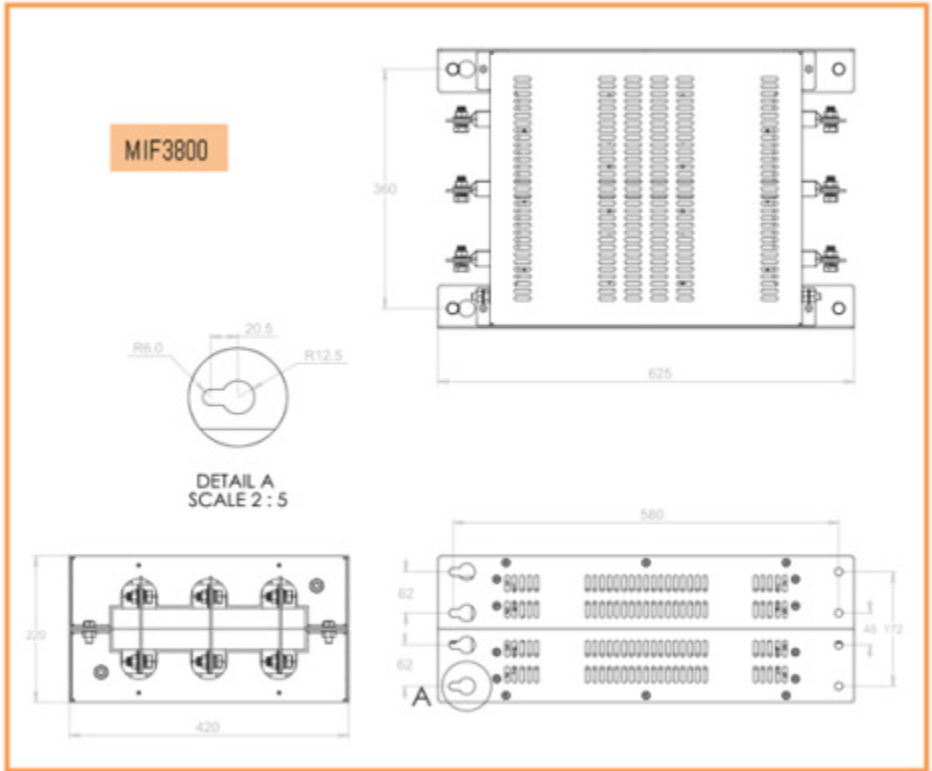

Figure A.1-3: EMI filter of MIF series

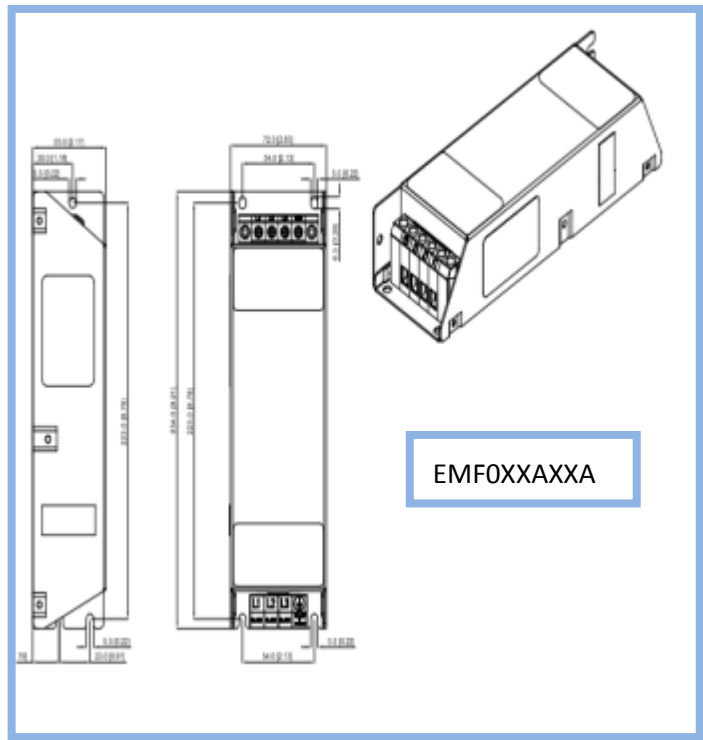

Figure A.1-4: EMI filter of KMF series

Dimensional drawings B84143D0120R127; B84143D0150R127

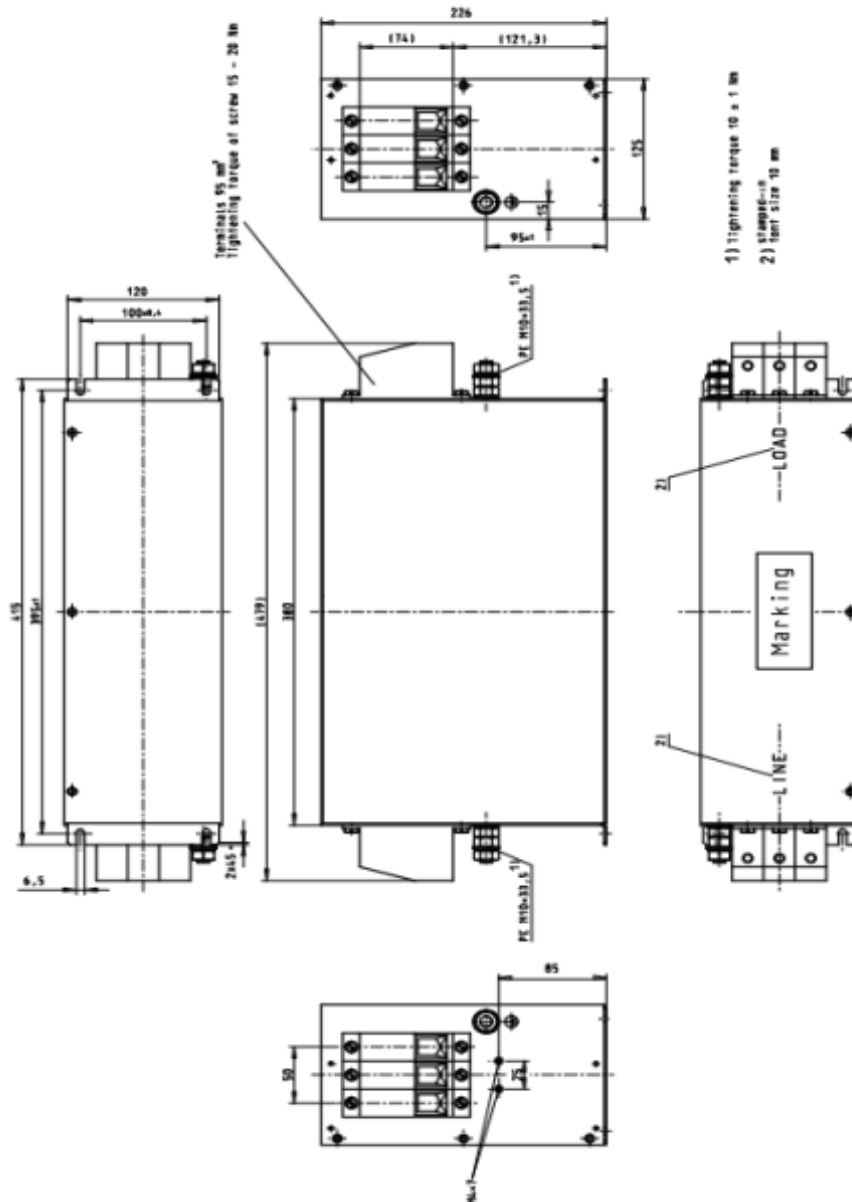

Figure A.1-5: B84143D0150R127 EMI filter



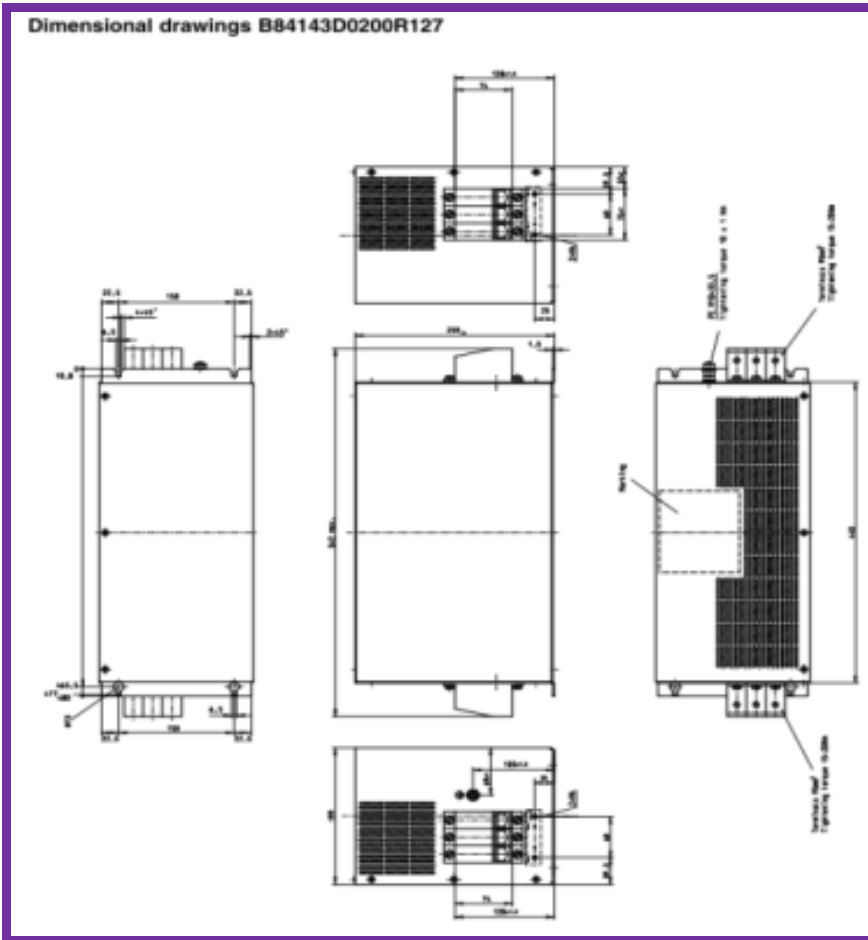

Figure A.1-6: B84143D0200R127 EMI filter

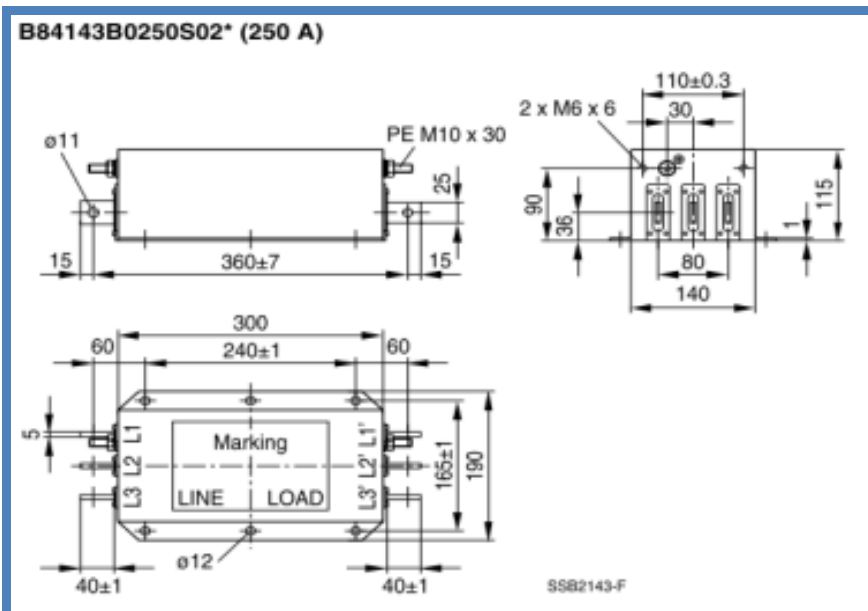
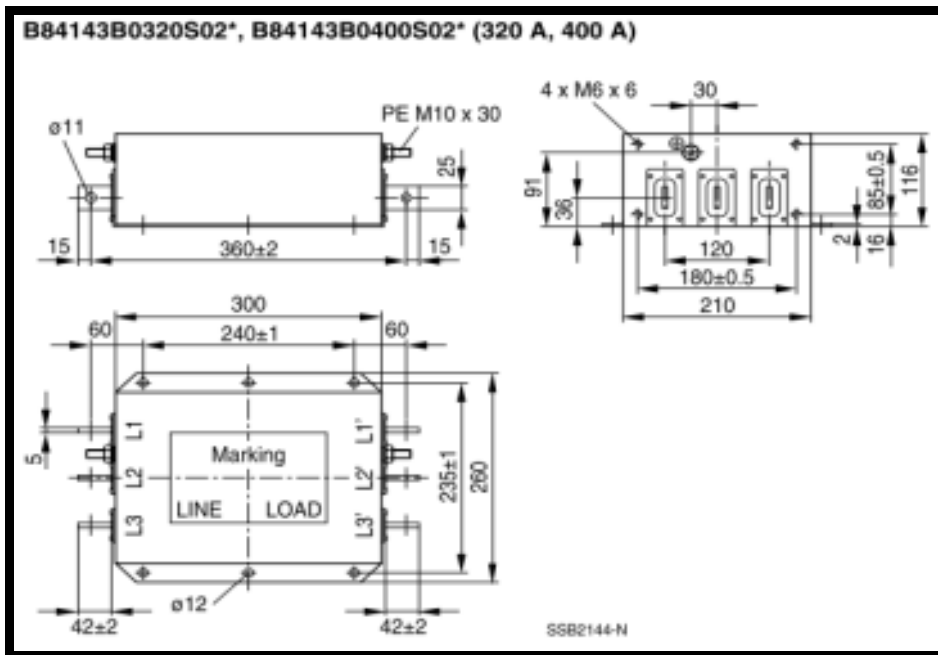
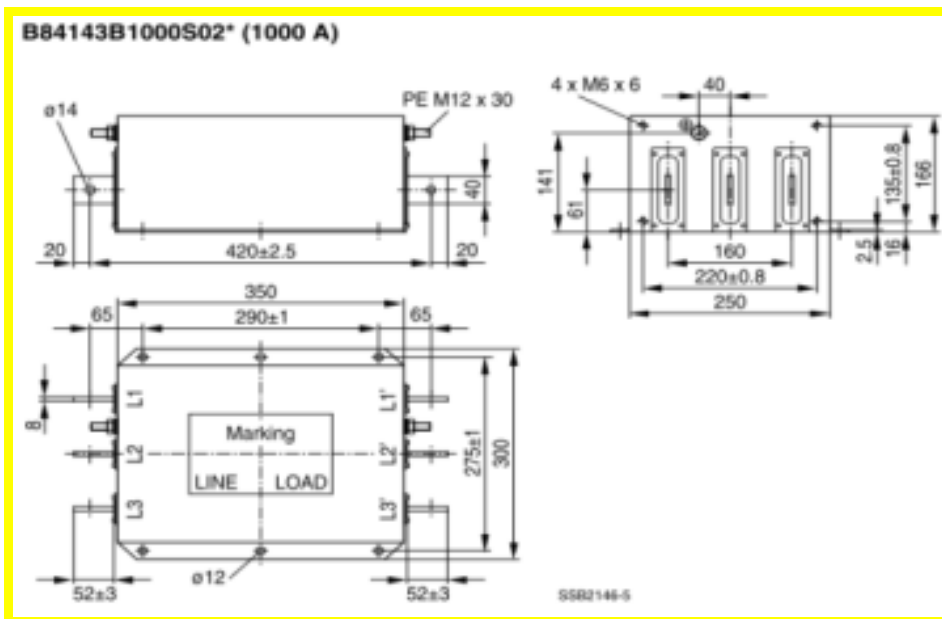

Figure A.1-7: B84143B0250S020 EMI filter



FigureA.1-8: B84143B0400S020 EMI filter



FigureA.1-9: B84143B1000S020 EMI filter

## A.2 Size of the zero-phase reactor

Model of the zero-phase reactor	RF002X00A	RF004X00A	RF008X00A	RF300X00A
Single-phase max. wire gauge(Diameter)	4/0	4AWG	8AWG	300MCM*4

The sizes of the zero-phase reactors are as follows:

model	A	B	C	D	E	F	G(Ø)	H	I
RF300X00A	241(9.488)	217(8.543)	114(4.488)	155(6.102)	42(1.654)	220(8.661)	6.5(0.256)	7.0(0.276)	20(0.787)
Torque:40~45kgf/cm <sup>2</sup>									

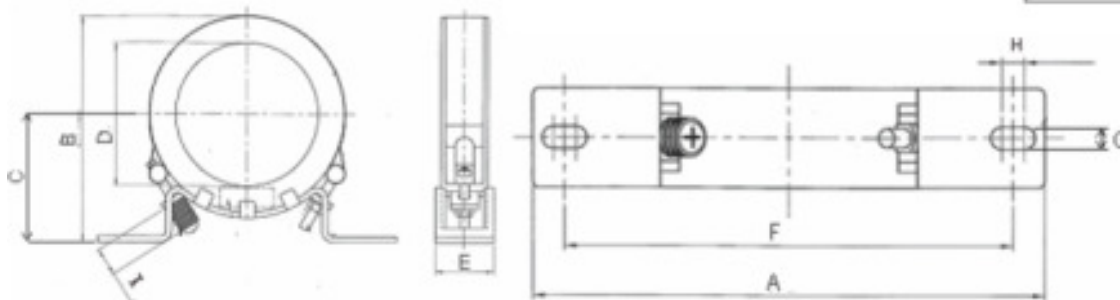

model	A	B	C	D	E	F	G(Ø)	Torque
RF008X00A	98 (3.858)	73 (2.874)	36.5 (1.437)	29 (1.142)	56.5 (2.224)	86 (3.386)	5.5 (0.217)	8~10kgf/cm <sup>2</sup>
RF004X00A	110 (4.331)	87.5 (3.445)	43.5 (1.713)	36 (1.417)	53 (2.087)	96 (3.780)	5.5 (0.217)	8~10kgf/cm <sup>2</sup>

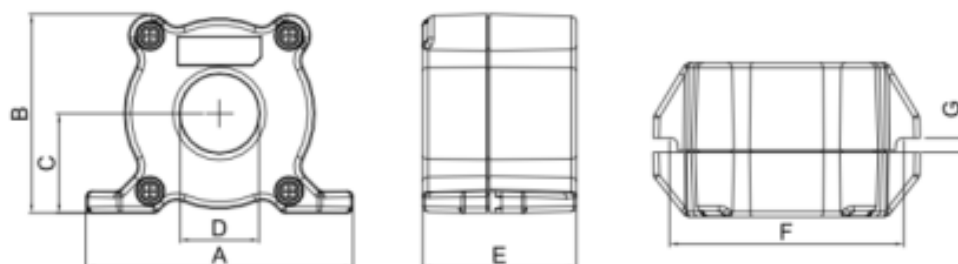

model	A	B	C	D	E	F	G(Ø)	H	Torque
RF002X00A	200 (7.874)	172.5 (6.791)	90 (3.543)	78 (3.071)	55.5 (2.185)	184 (7.244)	5.5 (0.217)	22 (0.866)	40~45kgf/cm <sup>2</sup>

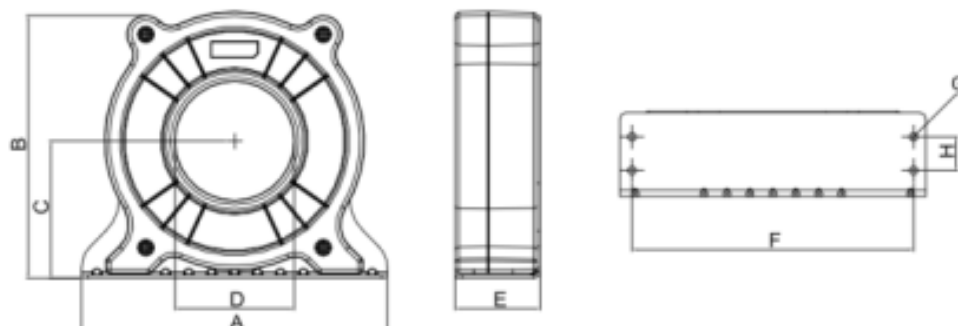

Table A2-1 Size of the zero-phase reactor

# A.3 Specifications of recommended Sunon AC Fan

Sunon A1123-HSL



## 120x120x38 mm

**High Air Flow**  
112~124 CFM



■ Specifications

Model	P/N	Bearing ● Vapo ○ BALL ⊗ Sleeve	Rating Voltage (VAC)	Freq. (Hz)	Power Current (AMP)	Power Consumption (WATTS)	Speed (RPM)	Air Flow (CFM)	Static Pressure (Inch-H <sub>2</sub> O)	Noise (dB(A))	Weight (g)
A1123-HST	(7).GN	⊗	115	50/60	0.28/0.25	23/21	2500/2750	112/124	0.30/0.28	43/46	525
<b>A1123-HSL</b>	(7).GN	⊗	115	50/60	0.28/0.25	23/21	2500/2750	112/124	0.30/0.28	43/46	525
A1123-HBT	(7).GN	○	115	50/60	0.28/0.25	23/21	2500/2750	112/124	0.30/0.28	44/47	525
A1123-HBL	(7).GN	○	115	50/60	0.28/0.25	23/21	2500/2750	112/124	0.30/0.28	44/47	525
A2123-HST	(7).GN	⊗	220-240	50/60	0.14/0.12	24/22	2500/2750	112/124	0.30/0.28	43/46	525
A2123-HSL	(7).GN	⊗	220-240	50/60	0.14/0.12	24/22	2500/2750	112/124	0.30/0.28	43/46	525
A2123-HBT	(7).GN	○	220-240	50/60	0.14/0.12	24/22	2500/2750	112/124	0.30/0.28	44/47	525
A2123-HBL	(7).GN	○	220-240	50/60	0.14/0.12	24/22	2500/2750	112/124	0.30/0.28	44/47	525

Frame : Aluminum alloy

Safety : UL-CUL/TUV/CE/CCC/BSMI

■ Air Flow-Static Pressure Characteristics

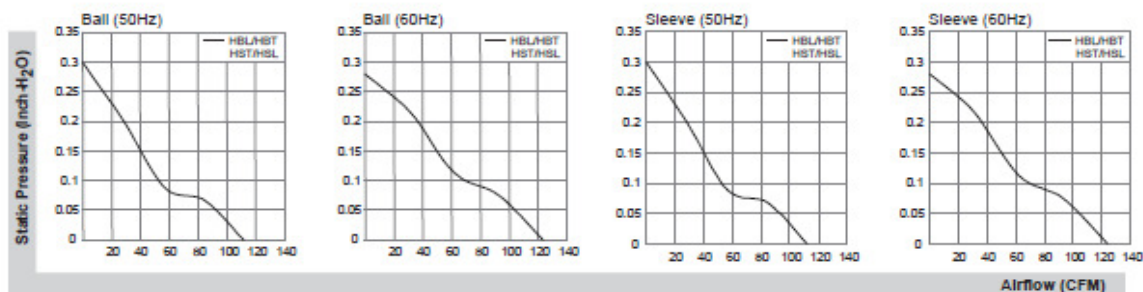

■ External dimensions(mm)

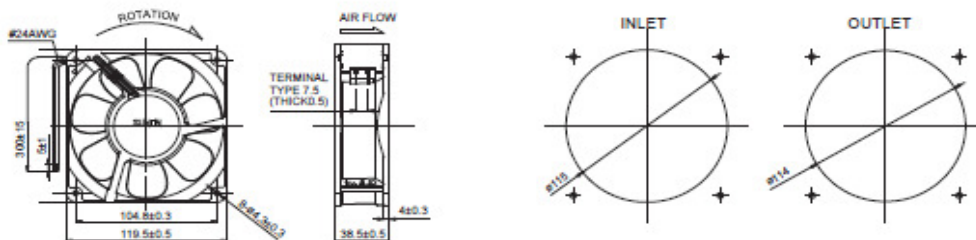

\*All model could be customized. Please contact with Sunon Sales.

\*Specifications are subject to change without notice. Please Visit SUNON website at <http://www.sunon.com> for update information.

176x176x89 mm

Alveolate Motor

315~335 CFM



■ Specifications

Model	P/N	Bearing	Rating Voltage	Freq.	Power Current	Power Consumption	Speed	Air Flow	Static Pressure	Noise	Weight
		● Vapo ○ BALL ⊙ Sleeve	(VAC)	(Hz)	(AMP)	(WATTS)	(RPM)	(CFM)	(Inch-H <sub>2</sub> O)	(dB(A))	(g)
A1179-HBT	TC.GN	○	115	50/60	0.25/0.27	24/30	2800/3250	315/335	0.65/0.8	62/66	1960
<b>A1179-HBL</b>	TC.GN	○	115	50/60	0.25/0.27	24/30	2800/3250	315/335	0.65/0.8	62/66	1960
A2179-HBT	TC.GN	○	220-240	50/60	0.11/0.15	23/30	2800/3250	315/335	0.65/0.8	62/66	1960
A2179-HBL	TC.GN	○	220-240	50/60	0.11/0.15	23/30	2800/3250	315/335	0.65/0.8	62/66	1960

Frame : Aluminum alloy

Safety : UL-CUL/TUV/CE/CCC/BSMI

■ Air Flow-Static Pressure Characteristics

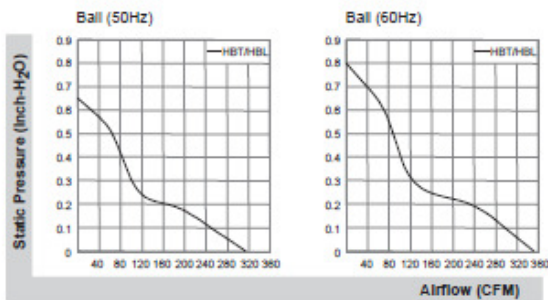

■ External dimensions(mm)

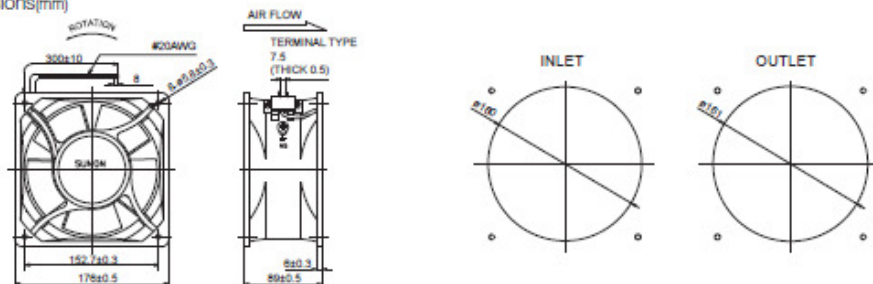

\*All model could be customized. Please contact with Sunon Sales.

\*Specifications are subject to change without notice. Please Visit SUNON website at <http://www.sunon.com> for update information.

ø254x89 mm

Alveolate Motor

425~870 CFM



■ Specifications

Model	P/N	Bearing	Rating Voltage	Freq.	Power Current	Power Consumption	Speed	Air Flow	Static Pressure	Noise	Weight
		● Vapo ○ BALL ⊙ Sleeve	(VAC)	(Hz)	(AMP)	(WATTS)	(RPM)	(CFM)	(Inch-H <sub>2</sub> O)	(dB(A))	(g)
A1259-MBL	TC.N.GN	○	115	50/60	0.23/0.23	20/23	1400/1600	425/500	0.27/0.31	54/57	2300
A1259-MBT	TC.N.GN	○	115	50/60	0.23/0.23	20/23	1400/1600	425/500	0.27/0.31	54/57	2300
A1259-HBL	TC.N.GN	○	115	50/60	0.60/0.65	63/72	2100/1900	650/585	0.35/0.31	62/60	2300
A1259-HBT	TC.N.GN	○	115	50/60	0.60/0.65	63/72	2100/1900	650/585	0.35/0.31	62/60	2300
A1259-XBL	TC.N.GN	○	115	50/60	0.83/1.10	88/120	2600/2900	800/870	0.76/0.62	68/70	2400
A1259-XBT	TC.N.GN	○	115	50/60	0.83/1.10	88/120	2600/2900	800/870	0.76/0.62	68/70	2400
A2259-MBL	TC.N.GN	○	220-240	50/60	0.15/0.13	23/30	1400/1600	425/500	0.27/0.31	54/57	2300
A2259-MBT	TC.N.GN	○	220-240	50/60	0.15/0.13	23/30	1400/1600	425/500	0.27/0.31	54/57	2300
A2259-HBL	TC.N.GN	○	220-240	50/60	0.24/0.27	56/60	2100/1900	650/585	0.35/0.31	62/60	2300
A2259-HBT	TC.N.GN	○	220-240	50/60	0.24/0.27	56/60	2100/1900	650/585	0.35/0.31	62/60	2300

Frame : Aluminum alloy

Safety : UL-CUL/TUV/CE/CCC/BSMI

■ Air Flow-Static Pressure Characteristics

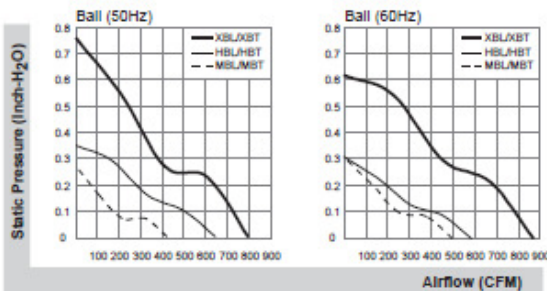

■ External dimensions(mm)

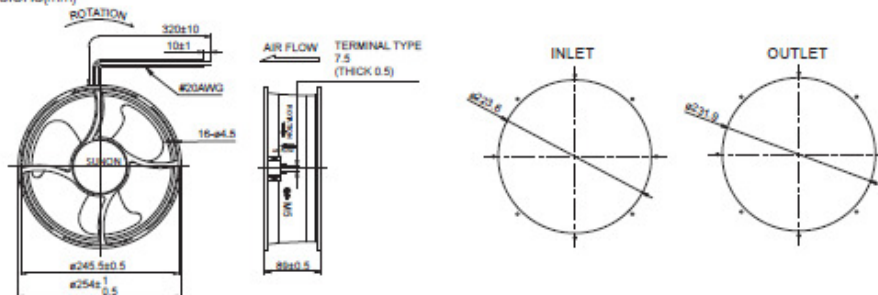

\*All model could be customized. Please contact with Sunon Sales.

\*Specifications are subject to change without notice. Please Visit SUNON website at <http://www.sunon.com> for update information.

ITEM	DESCRIPTION
RATED VOLTAGE	230 VAC
OPERATION VOLTAGE	220 - 240 VAC
INPUT CURRENT	3.6 A (MAX)
INPUT POWER	800 W (MAX)
SPEED	1800±10% R.P.M.
MAX. AIR FLOW (AT ZERO STATIC PRESSURE)	68.992 (MIN. 62.070 ) <sup>3</sup> M /MIN. 2432 (MIN. 2188) CFM
MAX. AIR PRESSURE (AT ZERO AIRFLOW)	78.6 (MIN. 63.6 ) mmH O <sub>2</sub> 3.094 (MIN. 2.506 ) inchH <sub>2</sub> O

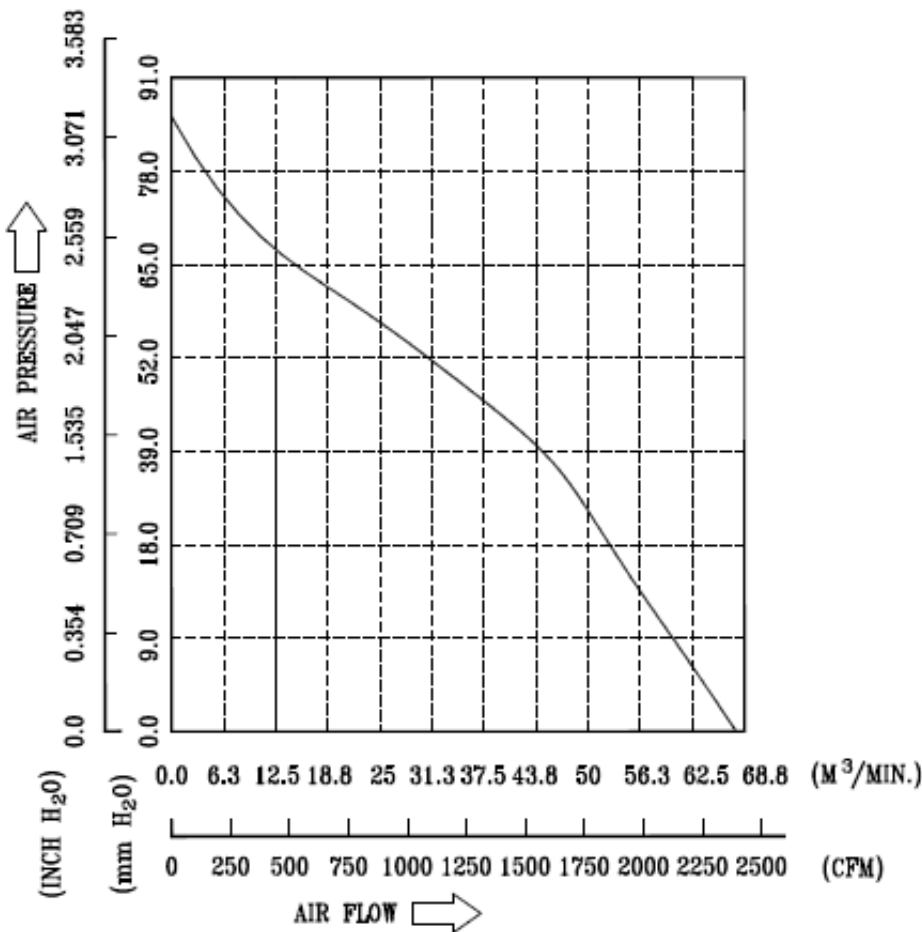

\* TEST CONDITION: INPUT VOLTAGE ----- OPERATION VOLTAGE  
 TEMPERATURE ----- ROOM TEMPERATURE  
 HUMIDITY ----- 65%RH